

Dimenzioniranje čelične konstrukcije proizvodnog pogona

Ivković, Marin

Master's thesis / Diplomski rad

2023

Degree Grantor / Ustanova koja je dodijelila akademski / stručni stupanj: **University of Rijeka, Faculty of Civil Engineering / Sveučilište u Rijeci, Građevinski fakultet**

Permanent link / Trajna poveznica: <https://um.nsk.hr/um:nbn:hr:157:276206>

Rights / Prava: [In copyright](#) / [Zaštićeno autorskim pravom.](#)

Download date / Datum preuzimanja: **2025-03-20**



Repository / Repozitorij:

[Repository of the University of Rijeka, Faculty of Civil Engineering - FCERI Repository](#)



image not found or type unknown

**SVEUČILIŠTE U RIJECI
GRAĐEVINSKI FAKULTET**

Marin Ivković

Dimenzioniranje čelične konstrukcije proizvodnog pogona

Diplomski rad

Rijeka, 2023.

**SVEUČILIŠTE U RIJECI
GRAĐEVINSKI FAKULTET**

Sveučilišni diplomski studij Građevinarstvo

Smjer: konstrukcije

Čelične konstrukcije

Marin Ivković

JMBAG: 0114031221

Dimenzioniranje čelične konstrukcije proizvodnog pogona

Diplomski rad

Rijeka, rujan 2023.

IZJAVA

Diplomski rad izradio sam samostalno, u suradnji s mentorom i uz poštivanje pozitivnih građevinskih propisa i znanstvenih dostignuća iz područja građevinarstva. Građevinski fakultet u Rijeci je nositelj prava intelektualnog vlasništva u odnosu na ovaj rad.

Marin Ivković

U Rijeci, 12.09.2023

ZAHVALA

Veliko hvala dugujem svom mentoru izv.prof.dr.sc. Mladenu Buliću mag.ing.aedif. na pruženoj pomoći, trudu, savjetima i prenesenom znanju tijekom izrade ovog rada. Također, zahvaljujem se svim ostalim profesorima i asistentima na stečenom znanju tijekom studiranja.

Posebno se zahvaljujem svojoj obitelji, curi i prijateljima na beskrajnoj podršci, ljubavi, motivaciji i strpljenju tijekom cijelog studiranja čime su mi olakšali i uljepšali ovo životno razdoblje.

Sažetak

U ovom diplomskom radu provedena je analiza i dimenzioniranje elemenata čelične konstrukcije proizvodnog pogona smještenog u Puli prema Eurocode-u 3, HRN EN 1993. Konstrukcija je simetrična, tlocrtnih dimenzija 60 x 33,6 m sa višestrešnim krovom nagiba 8°. Visina hale u sljemenu iznosi 11 m, a na krajevima i u sredini 12,18 m.

Analiza konstrukcije provedena je za stalno i promjenjivo djelovanje prema Eurocode-u 1 i pripadnim nacionalnim dodacima za Hrvatsku. U promjenjivo djelovanje uračunate su i dizalice različitih nosivosti (od 5 i 16 tona) koje uzduž hale klize po kranskoj stazi.

Statička analiza i dimenzioniranje provedeno je u programu *Robot Structural Analysis Professional* na granično stanje nosivosti (GSN) i granično stanje uporabivosti (GSU).

Provedeno je dimenzioniranje karakterističnih spojeva konstrukcije: priključak stupa i grednog nosača, priključak nosača u sljemenu te priključak stupa na temelj.

Ključne riječi: čelična konstrukcija, statička analiza, dimenzioniranje, Robot structural Analysis professional

Abstract

In this thesis, the analysis and dimensioning of the elements of the steel structure of the production facility located in Pula was carried out according to Eurocode 3, HRN EN 1993. The structure is symmetrical, with floor plan dimensions of 60 x 33,6 m with a multi-roofed roof with an 8° slope. The height of the hall in the ridge is 11 m, and at the ends and in the middle 12,18 m.

The structural analysis was carried out for constant and variable action according to Eurocode 1 and the corresponding national supplements for Croatia. Cranes of different capacities (of 5 and 16 tons) that slide along the hall along the crane track are also included in the variable operation.

The static analysis and dimensioning was carried out in the *Robot Structural Analysis Professional* program for the load limit state and serviceability limit state .

The dimensioning of the characteristic joints of the structure was carried out: the connection of the column and the beam support, the connection of the support in the ridge and the connection of the column to the foundation.

Keywords: steel structure, static analysis, dimensioning, Robot structural Analysis professional

SADRŽAJ

POPIS SLIKA
POPIS TABLICA.....
1. TEHNIČKI OPIS	1
1.1. OPIS KONSTRUKCIJE	1
1.2. TEMELJI.....	1
1.3. OPTEREĆENJA.....	1
1.4. O PRORAČUNU KONSTRUKCIJE	2
1.5. MATERIJALI ZA IZRADU KONSTRUKCIJE	2
1.6. PRIMIJENJENI PROPISI	2
1.7. ANTIKOROZIVNA ZAŠTITA [1]	2
1.8. PROTUPOŽARNA ZAŠTITA [1]	2
1.9. MONTAŽA.....	2
2. PROGRAM KONTROLE I OSIGURANJA KVALITETE [1].....	3
2.1. TEHNIČKI UVJETI ZA IZRADU I MONTAŽU ČELIČNE KONSTRUKCIJE	3
2.2. MATERIJALI ZA IZRADU ČELIČNE KONSTRUKCIJE	3
2.3. ZAVARI I VIJCI.....	4
2.4. IZVOĐENJE I MONTAŽA ČELIČNE KONSTRUKCIJE I UPRAVLJANJE KVALITETOM	4
2.5. PROPISI	8
2.6. OPĆE NAPOMENE ZA IZRADU ČELIČNE KONSTRUKCIJE U RADIONICI	8
2.7. ELEMENTI KONSTRUKCIJE	8
2.8. ANTIKOROZIVNA ZAŠTITA	9
2.9. PROTUPOŽARNA ZAŠTITA.....	9
2.10.PRIJEM ELEMENATA ČELIČNE KONSTRUKCIJE.....	9
LISTA PRISTANKA – COMPLIANCE LIST	10
3. ANALIZA DJELOVANJA	12
3.1. Stalna djelovanja (G)	12
3.1.1. Vlastita težina konstrukcije i konstrukcijskih elemenata	12
3.1.2. Pokrov.....	12
3.1.3. Instalacije.....	12
3.2. Snijeg (Q)	13
3.3. Vjetar (Q).....	16
3.3.1. Slučaj 1. – vanjski transverzalni pritisak, otvori zatvoreni ($\theta = 0^\circ$)	19
4.1.1. Slučaj 2. – vanjski transverzalni pritisak, otvori otvoreni ($\theta = 0^\circ$).....	25
4.1.2. Slučaj 3. – vanjski longitudinalni pritisak, otvori zatvoreni ($\theta = 90^\circ$).....	28

4.1.1. Slučaj 4. – vanjski longitudinalni pritisak, otvori otvoreni ($\theta = 90^\circ$)	31
3.4. Opterećenje kranom	33
4. Mehanička otpornost i stabilnost konstrukcije	37
IMPERFEKCIJE OKVIRA.....	50
KLASIFIKACIJA OKVIRA.....	51
5. KOMBINACIJE OPTEREĆENJA.....	52
5.1. Za granično stanje nosivosti (GSN ; ULS – Ultimate limit states)	52
5.2. Za granično stanje uporabivosti (GSU; SLS – Serviceability limit states).....	60
6. REZULTATI.....	69
6.1. Rezne sile.....	69
7. Dimenzioniranje elemenata konstrukcije.....	74
7.1. Vanjski stupovi.....	74
7.2. Vanjski zabatni stupovi.....	84
7.3. Unutarnji stupovi.....	87
7.4. Unutarnji zabatni stupovi	90
7.5. Gredni nosači.....	94
7.6. Gredni zabatni nosači	103
7.7. Podrožnice	106
7.8. Zabatni stupovi.....	109
7.9. Krovni uzdužni vezovi	112
7.10. Krovni poprečni vezovi	114
7.11. Vertikalni uzdužni vezovi	116
7.12. Vertikalni poprečni vezovi	118
7.13. Horizontalni nosači obloge (zabatni).....	120
7.14. Horizontalni nosači obloge (uzdužni)	123
7.15. Konzole	126
7.16. Kranska staza	128
8. DIMENZIONIRANJE PRIKLJUČAKA.....	132
8.1. Priključak stupa i grednog nosača	132
8.2. Priključak grednih nosača.....	148
8.3. Priključak stupa na temelj	162
9. Zaključak.....	174
10. Literatura	176
11. Nacrti	

POPIS SLIKA

Slika 1. Karta snježnih područja [2].....	13
Slika 2. Koeficijenti oblika opterećenja snijegom za višestruke krovove [3].....	14
Slika 3. Vrijednosti opterećenja snijegom na krov [izradio autor].....	15
Slika 4. Karta osnovne brzine vjetra $v_{b,0}$ [4]	16
Slika 5. Prikaz zona na vertikalnim površinama pri poprečnom djelovanju vjetra [izradio autor]	19
Slika 6. Koeficijenti kod višestrešnih krovova [4]	20
Slika 7. Djelovanje vjetra na jednostrešni krov za 0° i 180° [4].....	20
Slika 8. Raspodjela zona na 'jednostrešnom' krovu pri poprečnom djelovanju vjetra [izradio autor].....	21
Slika 9. Djelovanje vjetra na dvostrešni krov [4]	22
Slika 10. Raspodjela zona na krovu pri poprečnom djelovanju vjetrom [izradio autor]	22
Slika 11. Djelovanje vjetra za slučaj 1 [izradio autor].....	24
Slika 12. c_{pi} unutarnjeg pritiska vjetra [4]	25
Slika 13. Djelovanje vjetra za slučaj 2 [izradio autor].....	27
Slika 14. Prikaz zona na vertikalnim površinama pri uzdužnom djelovanju vjetra [izradio autor]	28
Slika 15. Pogled na krov pri uzdužnom djelovanju vjetra [izradio autor].....	29
Slika 16. Djelovanje vjetra za slučaj 3 [izradio autor].....	30
Slika 17. Djelovanje vjetra za slučaj 4 [izradio autor].....	32
Slika 18. Položaj 1 [izradio autor]	34
Slika 19. Položaj 2 [izradio autor].....	34
Slika 20. Položaj 3 [izradio autor].....	34
Slika 21. Položaj 4 [izradio autor]	34
Slika 22. Položaj 5 [izradio autor]	35
Slika 23. Položaj 6 [izradio autor]	35
Slika 24. Položaj 7 [izradio autor].....	35
Slika 25. Položaj 8 [izradio autor].....	35
Slika 26. Položaj 9 [izradio autor]	36
Slika 27. Položaj 10 [izradio autor]	36
Slika 28. Položaj 11 [izradio autor]	36
Slika 29. Položaj 12 [izradio autor]	37
Slika 30. Model konstrukcije [izradio autor].....	37
Slika 31. Opterećenje vlastitom težinom [izradio autor].....	38

Slika 32. Stalno opterećenje [izradio autor]	39
Slika 33. Nesimetrično opterećenje snijegom [izradio autor]	40
Slika 34. Simetrično opterećenje snijegom [izradio autor]	41
Slika 35. Opterećenje vjetrom (slučaj 1) [izradio autor]	43
Slika 36. Opterećenje vjetrom (slučaj 2) [izradio autor]	45
Slika 37. Opterećenje vjetrom (slučaj 3) [izradio autor]	47
Slika 38. Opterećenje vjetrom (slučaj 4) [izradio autor]	49
Slika 39. Položaj i vrijednosti dijagrama na vanjskom stupu mjerodavnom za dimenzioniranje [izradio autor]	74
Slika 40. Položaj i vrijednosti dijagrama na vanjskom zabatnom stupu mjerodavnom za dimenzioniranje [izradio autor]	84
Slika 41. Položaj i vrijednosti dijagrama na unutarnjem stupu mjerodavnom za dimenzioniranje [izradio autor]	87
Slika 42. Položaj i vrijednosti dijagrama na zabatnom unut. stupu mjerodavnom za dimenzioniranje [izradio autor]	91
Slika 43. Položaj i vrijednosti dijagrama na grednom nosaču mjerodavnom za dimenzioniranje [izradio autor]	94
Slika 44. Položaj i vrijednosti dijagrama na zabatnom grednom nosaču mjerodavnom za dimenzioniranje [izradio autor]	103
Slika 45. Položaj i vrijednosti dijagrama na podrožnici mjerodavnoj za dimenzioniranje [izradio autor]	106
Slika 46. Položaj i vrijednosti dijagrama na zabatnom stupu mjerodavnom za dimenzioniranje [izradio autor]	109
Slika 47. Položaj i vrijednosti dijagrama na uzdužnom krovnom vezu mjerodavnom za dimenzioniranje [izradio autor]	112
Slika 48. Položaj i vrijednosti dijagrama na poprečnom krovnom vezu mjerodavnom za dimenzioniranje [izradio autor]	114
Slika 49. Položaj i vrijednosti dijagrama na vertikalnom uzdužnom vezu mjerodavnom za dimenzioniranje [izradio autor]	116
Slika 50. Položaj i vrijednosti dijagrama na vertikalnom poprečnom vezu mjerodavnom za dimenzioniranje [izradio autor]	118
Slika 51. Položaj i vrijednosti dijagrama na horizontalnom zabatnom nosaču obloge mjerodavnom za dimenzioniranje [izradio autor]	120
Slika 52. Položaj i vrijednosti dijagrama na horizontalnom uzdužnom nosaču obloge mjerodavnom za dimenzioniranje [izradio autor]	123

Slika 53. Položaj i vrijednosti dijagrama na konzoli mjerodavnoj za dimenzioniranje [izradio autor].....	126
Slika 54. Položaj i vrijednosti dijagrama na kranskoj stazi mjerodavnoj za dimenzioniranje [izradio autor]	129

POPIS TABLICA

Tablica 1. Karakteristične vrijednosti proračunskog opterećenja snijegom na tlu [izradio autor, 2]	13
Tablica 2. Kategorije terena i parametri terena [4]	17
Tablica 3. Podatci djelovanja dizalice od 5 t po jednom kotaču [5]	33
Tablica 4. Podatci djelovanja dizalice od 16 t po jednom kotaču [5].....	33
Tablica 5. Vrijednosti koeficijenta ψ	52
Tablica 6. Maksimalne rezne sile vanjskih stupova [izradio autor].....	69
Tablica 7. Maksimalne rezne sile vanjskih zabatnih stupova [izradio autor].....	69
Tablica 8. Maksimalne rezne sile unutarnjih stupova [izradio autor]	69
Tablica 9. Maksimalne rezne sile grednih nosača [izradio autor]	70
Tablica 10. Maksimalne rezne sile grednih zabatnih nosača [izradio autor].....	70
Tablica 11. Maksimalne rezne sile podrožnica [izradio autor].....	70
Tablica 12. Maksimalne rezne sile zabatnih stupova [izradio autor].....	71
Tablica 13. Maksimalne rezne sile krovnih uzdužnih vezova [izradio autor]	71
Tablica 14. Maksimalne rezne sile krovnih poprečnih vezova [izradio autor]	71
Tablica 15. Maksimalne rezne sile vertikalnih uzdužnih vezova [izradio autor].....	72
Tablica 16. Maksimalne rezne sile vertikalnih poprečnih vezova [izradio autor].....	72
Tablica 17. Maksimalne rezne sile zabatnih horizontalnih nosača obloge [izradio autor].....	72
Tablica 18. Maksimalne rezne sile uzdužnih horizontalnih nosača obloge [izradio autor].....	73
Tablica 19. Maksimalne rezne sile konzole [izradio autor].....	73
Tablica 20. Maksimalne rezne sile kranske staze [izradio autor].....	73
Tablica 21. Karakteristike profile HEA 340 [izradio autor]	77
Tablica 22. Odabrani profili elemenata [izradio autor]	131
Tablica 23. Iskoristivosti elemenata i spojeva [izradio autor]	175

1. TEHNIČKI OPIS

1.1. OPIS KONSTRUKCIJE

Čelična konstrukcija proizvodnog pogona osnih tlocrtnih dimenzija 60 x 33,60 m biti će smještena u Puli.

Visina konstrukcije od kote terena do najviše točke stupa iznosi 11 m, a visina konstrukcije mjerena od kote terena do kote sljemena iznosi 12,18 m. Krov hale je višestrešni, nagiba 8°.

Predviđeni pokrov konstrukcije je od sendvič panela debljine 10 cm, Trimoterm perform C100.

Konstrukcija se sastoji od 11 okvira na razmaku od 6 m. Za vanjske i unutarnje stupove, te gredne nosače izabrani su profili HEA 340, dok su na zabatima stupovi i nosači od profila IPE 330.

Za podrožnice su izabrani profili IPE 270, te su na međusobnom razmaku od 2 m. Predviđeno je njihovo postavljanje na glavne nosače. Raspona su 6 m.

Horizontalni nosači obloge na zabatu i uzdužno izvest će se od UPN 240 profila koji se nalaze na međusobnom razmaku od 2,625 m. Preko njih se fasadni paneli pričvršćuju na konstrukciju.

Za stabilizacijske krovne i uzdužne vezove odabrani su puni profili promjera 25 mm.

Uzduž hale prometuju dvije dizalice različitih nosivosti, od 5 i 16 tona. Djeluju po kranskim stazama profila HEA 280 koje su preko kratkih konzola izvedenih od profila IPE 300 pričvršćene na konstrukciju.

Na hali su predviđena 4 otvora dimenzija 5 x 4 m prolaz vozila, po 2 na zabatnim stranama te 4 manja otvora dimenzija 2 x 1 m za prolaz osoblja. Na uzdužnim stranama predviđeno je po 20 prozora od kojih će svaki drugi imati mogućnost otvaranja.

1.2. TEMELJI

Unutarnji i vanjski stupovi su zglobno oslonjeni na temelje samce dimenzija 1,1 x 1,1 m, dubine temeljenja 0,9 m te međusobno povezani trakastim temeljima.

Beton korišten za temelje je klase C20/25. Predviđena armatura B500B.

1.3. OPTEREĆENJA

Na konstrukciju djeluju stalna, promjenjiva i korisna opterećenja. U stalna opterećenja spadaju: vlastita težina konstrukcije i konstrukcijskih elemenata, težina pokrova te instalacija.

U promjenjiva opterećenja spada opterećenje snijegom i vjetrom, a pod korisno djelovanje ubraja se djelovanje dizalica. Sva opterećenja odabrana su prema normama EC1.

Vlastita težina elemenata konstrukcije računa se kao gravitacijsko djelovanje ovisno o dimenzijama elemenata.

1.4. O PRORAČUNU KONSTRUKCIJE

Proračun unutarnjih sila, pomaka, progiba te dimenzioniranje elemenata čelične konstrukcije provedeno su u skladu s Eurocode-om u programu Autodesk Robot Structural Analysis.

1.5. MATERIJALI ZA IZRADU KONSTRUKCIJE

Korišteni materijali:

- Svi elementi nosive čelične konstrukcije izrađeni su od čelika S 275
- Za priključak stupa na temelj korišteno je 4 ankera M24, k.v. 8.8 i beton klase C20/25 s armaturom B500B
- Za priključak stupa i grednog nosača korišteno je 6 vijaka M20, k.v. 8.8
- Za priključak grednih nosača u sljemenu korišteno je 8 vijaka M20, k.v. 8.8

1.6. PRIMIJENJENI PROPISI

Analiza konstrukcije provedena je po europskim propisima primjenjujući odgovarajuće Nacionalne dodatke

- HRN EN 1990:2011 i HRN EN 1990:2011/NA:2011
- HRN EN 1991-1-1:2014 i HRN EN 1991-1-1:2014/NA:2014
- HRN EN 1991-1-3:2012 i HRN EN 1991-1-3:2012/NA:2014
- HRN EN 1991-1-4:2012 i HRN EN 1991-1-4:2012/NA:2014
- HRN EN 1993-1-4:2014 i HRN EN 1993-1-1:2014/NA:2014
- HRN EN 1993-1-8:2008

1.7. ANTIKOROZIVNA ZAŠTITA [3]

Elementni čelične konstrukcije hale radionički se štite jednim temeljnim premazom na prethodno opjeskarenoj podlozi do čistoće Sa 2 ½. Završetkom montaže potrebno je popraviti sva oštećenja temeljnog radioničkog premaza. Nakon odmašćivanja površine nanosi se drugi temeljni premaz. Debljina temeljnih premaza na organskoj osnovi iznosi 2 x 30 µm.

Završna obrada propisana je prikazom mjera zaštite od požara sredstvima s karakteristikom F30.

1.8. PROTUPOŽARNA ZAŠTITA [3]

S obzirom da se radi o hali, zahtijevana vatrootpornost elemenata konstrukcije iznosi F30, što znači da se očekuje da zadrži požar do 30 min. Na podlogu s dva temeljna premaza nanosi se zaštitno sredstvo s karakterističnom vatrootpornosti F30 te temeljnom antikorozivnom zaštitom.

1.9. MONTAŽA

Elementi konstrukcije izrađuju se u radionici i dovoze na gradilište, te potom povezuju vijčanim spojevima. Prije početka montaže izvode se armiranobetonski temeljni samci međusobno povezani trakastim temeljima.

2. PROGRAM KONTROLE I OSIGURANJA KVALITETE [3]

2.1. TEHNIČKI UVJETI ZA IZRADU I MONTAŽU ČELIČNE KONSTRUKCIJE

Izrada čelične konstrukcije mora se povjeriti onom izvođaču koji ima odgovarajuće reference već izvedenih sličnih objekata. U tehničkoj dokumentaciji (projektu) predviđena je vrsta i kvaliteta materijala od kojeg treba izraditi konstrukciju. Odstupanja u kvaliteti materijala može odobriti jedino projektant konstrukcije.

Izvođač radova dužan je prije početka radova predočiti nadzornom inženjeru sljedeću važeću dokumentaciju:

- uvjerenja o kvaliteti osnovnog i dodatnog materijala, sredstava za spajanje te sredstava za antikorozivnu zaštitu,
- uvjerenje o podobnosti pogona za izvođenje zavarivačkih radova
- uvjerenja zavarivača koji će raditi na izradi konstrukcije za vrstu zavarivačkih radova koja će se primjenjivati, za traženu debljinu, materijal i položaj zavarivanja,
- specifikacija postupaka zavarivanja i odobrenje o primjeni postupaka zavarivanja,
- uvjerenja o ispravnosti strojeva za izvođenje zavarivačkih radova
- plan izvođenja zavarivačkih radova
- uvjerenje o podobnosti izvođača za izvođenje antikorozivnu zaštite
- ovlaštenja svih odgovornih osoba u sustavu interne kontrole izvođača,
- plan rada interne kontrole izvođača.

Prije pristupanja radovima na montaži potrebno je predočiti odobreni *Projekt montaže*.

Navedena dokumentacija sastavni je dio dokumentacije za tehnički pregled konstrukcije. Tijekom izrade i montaže konstrukcije izvođač radova dužan je voditi zakonom propisane dnevnik, koje je uz internu kontrolu izvođača dužan ovjeriti i nadzorni inženjer. Ako se materijal za izradu konstrukcije nabavlja i tijekom izrade čelične konstrukcije, potrebno je nadzornom organu staviti na uvid odgovarajuća uvjerenja o kvaliteti.

Prije isporuke konstrukcije na gradilište vrši se prijem konstrukcije u radionici uz pribavljenu kompletnu dokumentaciju o kvaliteti. O prijemu konstrukcije sastavlja se zapisnik koji ovjeravaju svi sudionici izgradnje: investitor, izvođač radova u radionici, nadzorni inženjer te predstavnik izvođača radova na montaži konstrukcije.

2.2. MATERIJALI ZA IZRADU ČELIČNE KONSTRUKCIJE

Materijali za izradu čelične konstrukcije definirani su u poglavlju 3 (Tehnički opis) i u poglavlju 5 (Statički proračun).

Dokaz kvalitete, dimenzije i tolerancije čeličnih proizvoda

Svi čelični proizvodi koji se koriste trebaju biti ispitani u skladu s odgovarajućom normom danom u dijelu Kvaliteta čeličnih proizvoda. Proizvođač čeličnih proizvoda treba deklarirati svoj proizvod na temelju ispitivanja koristeći inspeksijsku potvrdu tip 3.1 prema normi HRN EN 10204:2007. Izvođač čelične konstrukcije treba imati pristup inspeksijskom dokumentu prema HRN EN

10204:2007 od proizvođača za sve čelične proizvode korištene u izvedbi nosive konstrukcije i dostaviti ih na zahtjev nadzornom inženjeru ili građevinskoj inspekciji. Dimenzije i tolerancije čeličnih proizvoda trebaju biti u skladu s normama danim u dijelu Kvaliteta čeličnih proizvoda.

Površina čeličnih proizvoda

Površinske greške toplo valjanih čeličnih ploča, širokih traka i profila koje nisu u skladu sa zahtjevima norma niza HRN EN 10163:2007 moraju se ispraviti da budu u skladu s prethodno navedenom normom. Analogno vrijedi i za šuplje profile koji moraju biti u skladu s normama HRN EN 10210:2008 (toplo oblikovani šuplji profile od nelegiranih i sitnozrnastih konstrukcijskih čelika) i HRN EN 10219:2008 (hladno oblikovani šuplji profile za čelične konstrukcije od nelegiranih i sitnozrnatih čelika).

Zamjena materijala ili oblika

Kvaliteta materijala ili oblik čeličnog proizvoda, uz suglasnost projektanta čelične konstrukcije, može se zamijeniti ako se može dokazati da konstrukcijska svojstva nisu manja od proračunom odabranih proizvoda te da je zadržana kompatibilnost s proračunatom konstrukcijom.

2.3. ZAVARI I VIJCI

Zavari

Zavari na čeličnoj konstrukciji će se točno prikazati i specificirati na izvedbenim nacrtima (radionička dokumentacija) u skladu s normama navedenim u točki 2.3.5. Zahtijevana kvaliteta punila zavara kao što su granica popuštanja, vlačna čvrstoća, relativna deformacija pri slomu i minimalna energija loma, treba biti jednaka ili bolja od zahtijevane kvalitete osnovnog materijala.

Vijci

Vijci, matice i podloške koje će se primjenjivati pri montaži čeličnih konstrukcije biti će točno specificirane na izvedbenim nacrtima (radionička dokumentacija) u skladu s normama navedenim u točki 2.3.5.

2.4.IZVOĐENJE I MONTAŽA ČELIČNE KONSTRUKCIJE I UPRAVLJANJE KVALITETOM

Izvođenje - zavarivanje

Točni oblici i dimenzije zavara biti će dani u izvedbenom projektu. Ovdje će se navesti samo preporuke i zahtjevi kojih se potrebno pridržavati pri izradi izvedbene dokumentacije i izvođenja.

a/ Općenito

Postupci zavarivanja trebaju biti u skladu s preporukama danim u normi HRN EN 1011. Općenito zavarivanje treba biti elektro-lučno u skladu s HRN EN 1011-1:2009, a prema potrebi i s HRN EN 1011-2:2002, te drugim zahtjevima prikazanim u ovom poglavlju. Izvođač mora imati sustav za upravljanje zavarivanjem koji zadovoljava uvjete kvalitete definirane u normi HRN EN ISO 3834-3:2007.

Sva dokumentacija zavarivanja (kvalifikacije zavarivača, zapisi kvalifikacija postupaka zavarivanja, specifikacije postupaka zavarivanja i povezane radne upute) za primjenu treba

biti pregledana od strane osobe odgovorne za koordinaciju postupka zavarivanja. Ako je zahtijevano, dokumentacija se mora staviti na raspolaganje nadzornom inženjeru i, ako je isto imenovano, inspeksijskom tijelu.

Izvođač treba osigurati da su materijali koji se zavaraju kompatibilni s primijenjenim postupkom zavarivanja.

Spojevi trebaju biti pripremljeni u skladu s normama HRN EN ISO 9692-1:2013 i HRN EN ISO 9692-2:1999. Potrebno je poduzeti mjere opreza kako bi se osigurala čistoća spoja prije zavarivanja.

b/ Osposobljenost zavarivača

Provjera osposobljenosti zavarivača treba biti u skladu sa zahtjevima norme HRN EN ISO 9606-1:2017. Provjera osposobljenosti zavarivača treba biti posvjedočena i certifikatom potvrđenim od strane Ispitivača ili Ispitnog tijela. Certifikat vrijedi pod uvjetom da ispunjava uvjete za odobravanje certifikata koji se navode u normi HRN EN ISO 9606-1:2017.

c/ Postupak zavarivanja

Pismena specifikacija postupka zavarivanja treba biti dostupna u skladu s normom HRN EN ISO 15609-1:2008 i provjerena u skladu s normom HRN EN ISO 15614-1:2017 od strane izvođača čelične konstrukcije. One moraju biti u skladu s normom HRN EN 1011-2:2002 Prilog C, Postupak A kako bi se izbjeglo puknuće vodikom i Prilogom D da se osigura odgovarajuća čvrstoća u zoni utjecaja topline.

Ispitivač ili Ispitno tijelo mora provjeriti da su zapisi kvalifikacija postupka zavarivanja u skladu s normom HRN EN ISO 15614-1:2017.

Odgovarajuće radne upute trebaju biti izrađene iz zapisa kvalifikacija postupka zavarivanja pod nadzorom koordinatora postupka zavarivanja. Radne upute trebaju biti ili pismene specifikacije postupka zavarivanja ili moraju sadržavati sve relevantne informacije zahtijevane u pismenoj specifikaciji postupka zavarivanja u drugim formatima, koji odgovaraju sustavu izvođača čelične konstrukcije.

d/ Postupak montaže

Kratki privremeni zavari mogu se koristiti pod uvjetom:

- (i) da su položeni u područje koje se zavaruje te potom temeljito odstranjeni brušenjem tako da je sljedeće zavarivanje nepromijenjeno;
- (ii) da se obavljaju od strane zavarivača kvalificiranog kao u b/ Osposobljenost zavarivača kao kratka dužina normalnih zavara do dužine koja iznosi najmanje četiri debljine debljeg spojenog dijela dugog najmanje 50 mm, te da je postupak zavarivanja u skladu s točkom c/ Postupak zavarivanja.
- (iii) da su naknadno potpuno rastopljeni pomoću postupaka zavarivanja kao u c/ Postupak zavarivanja te da se dokaže da su potpuno rastopljeni tijekom naknadnog varenja;
- (iv) da se nalaze dalje od zone gdje će se odvijati naknadno zavarivanje i u zoni u kojoj se javljaju samo tlačne sile
Napomena: Korištenjem (iv) trebalo bi biti moguće osigurati ploču stupa tijekom prijevoza.

Redosljed zavarivanja spoja ili redosljed izvedbe spoja mora biti takav daje distorzija minimalna. Zavarivanje dijelova potrebnih za izradu ili montažu treba biti u skladu sa zahtjevima za stalne zavare. Ako je neophodno uklanjanje, dijelovi moraju biti izrezani ili uklonjeni plamenom na mjestima udaljenim ne manje od 3 mm od površine ishodnog materijala. Preostali materijal mora biti u ravnini, a područje vizualno pregledano. Ako je

debljina ishodnog materijala veća od 20 mm također se mora provjeriti testiranjem penetrantima. Dijelovi potrebni za izradu ili montažu ne smiju se uklanjati čekićanjem.

e/ Nerazorno ispitivanje zavara

Vizualni pregled treba biti proveden za sve zavare. Ako su sljedeći uvjeti ispunjeni nije obavezno dodatno nedestruktivno ispitivanje:

- "spoj" je kutno zavaren,
- duljina kutnog zavara nije veća od 10mm,
- najveća delijina ne iznosi više od 20mm.

Ako navedeni uvjeti nisu ispunjeni opseg pregleda mora biti u skladu s normom HRN EN 1090-2:2011. Ako su u radionici ispunjeni svi uvjeti tada mora biti pokrenut mjesečni program daljnjeg nedestruktivnog ispitivanja od strane osobe odgovorne za koordinaciju postupka zavarivanja na način da je reprezentativni uzorak svakog mjesečnog izlaza tretiran odgovarajućim nedestruktivnim testiranjem.

Zahtjevi pregleda mogu biti reducirani po nahođenju inženjera na temelju zadovoljavajuće izvedbe u početnoj proizvodnji. Isto tako, ako testiranje pokazuje da postoje problemi s kvalitetom zavara (u sličnim materijalima, metodama montaže ili postupcima zavarivanja) zahtjevi nedestruktivnog testiranja trebaju se povećati i proširiti na neobavezne dijelove.

Rezultati vizualnog pregleda, površinske detekcije pukotina i ultrazvučnog ispitivanja moraju biti zapisani i dostupni na uvid.

Potpuni vizualni pregled treba se obaviti tijekom zavarivanja te po završetku utvrditi kvalitetu proizvodnje. Ako nije navedeno u specifikaciji projekta, vizualni pregled treba biti proveden u skladu sa smjernicama navedenim u normi HRN EN 1090-2:2011 i ostalim odgovarajućim normama.

Odgovarajuće kvalificirana osoba za vizualni pregled zavara može biti inspektor za zavarivanje ili zavarivač koji može pružiti dokaz da je obučen i pripremljen za vizualni pregled relevantne vrste zavara tijekom i nakon zavarivanja. Razina kvalitete treba biti u skladu s razinama danim u normi HRN EN 1090-2:2011 i odgovarajućem standardu te specifikaciji projekta. Svi utvrđeni nedostaci ocjenjivati će se u skladu sa zahtijevanom razinom kvalitete kako bi se utvrdila potreba za popravcima i mjerama zaštite.

Svi zavari koji će nakon sljedećih radnji postati nedostupni trebaju biti ispitani u skladu s normom HRN EN 1090-2:2011 i odgovarajućim standardom prije gubitka pristupa.

Ako postoji opasnost od naknadnog pucanja rok treba biti prije konačnog pregleda. Bez obzira koji se vremenski period koristi, isti mora biti naveden u inspeksijskim zapisima. Ako se može dokazati od strane izvođača kroz zapise da nema rizika od naknadnog pucanja, vrijeme odgode može se smanjiti ili ukinuti ovisno o nahođenju inženjera.

Ako je potreban detaljniji pregled površine zavara u skladu s normom HRN EN 1090-2:2011 i odgovarajućim standardom, ispitivanje magnetskim česticama treba biti korišteno u skladu s preporukama danim u normi HRN EN ISO 17638:2016 prije čega treba prethoditi vizualni pregled prema normi HRN EN ISO 17637:2017. Ako ispitivanje magnetskim česticama nije praktično, ispitivanje penetrantima treba se koristiti u skladu s preporukama danim u normi HRN EN ISO 3452.

Završno površinsko otkrivanje pukotina u zavarenom spoju obavlja se nakon završetka zavara u skladu s vremenom čekanja danim u normi HRN EN 1090-2:2011 i odgovarajućim standardima.

Prikladno kvalificirana osoba za površinsko otkrivanje pukotina zavara može biti inspektor za zavarivanje ili zavarivač koji ima nacionalno priznatu važeću svjedodžbu o sposobnosti u otkrivanju površinskih pukotina za odgovarajuće vrste posla.

Ako je potrebno ultrazvučno ispitivanje u skladu s normom HRN EN 1090-2:2011 i

odgovarajućim standardima, to mora biti u skladu s normom HRN EN ISO 17640:2017 koristeći referentnu razinu prema metodi 1, procijenjenu referentnu razinu - 14dB (20% DAC) i razinu ispita B ukoliko nije drukčije dogovoreno od strane inženjera.

Ultrazvučno ispitivanje zavarenog spoja obavlja se nakon završetka zavara u skladu s vremenima odgode danima u normi HRN EN 1090-2:2011 i odgovarajućim standardima.

Osobe koje obavljaju završno ultrazvučno ispitivanje zavara trebaju posjedovati važeću nacionalno priznatu potvrdu o osposobljenosti. Kriteriji prihvaćanja, korektivne mjere i ponovno ispitivanje moraju biti u skladu s normom HRN EN 1090-2:2011 i odgovarajućim normama. Ukoliko se utvrde nesukladni zavari opseg pregleda mora se povećati te utvrditi i ukloniti izvor nedostataka.

Izvođenje – zaštita od korozije

Zaštita čelične konstrukcije od korozije opisana je u poglavlju 3 (Tehnički opis).

Montaža čelične konstrukcije

a/ Općenito

Izvođač treba napraviti tehnološki plan montaže čelične konstrukcije. Sa montažom čelične konstrukcije može se započeti nakon što Plan montaže odobri nadzorni inženjer i projektant konstrukcije.

b/ Kontrole u toku izrade, transporta i montaže

Tijekom izrade konstrukcije u radionici i montaže izvoditelj je dužan voditi zakonom propisane dnevnik i provoditi unutarnju kontrolu u skladu s planom kontrole. Dužnost je nadzornog inženjera kontrolirati izvedbu u svim fazama izrade i montaže, tj. usklađenost s tehničkom dokumentacijom i važećim tehničkim normama i pravilima, ovjeravati navedene dokumente i ateste, te zapisnik o preuzimanju elemenata u radionici prije isporuke na montažu.

Izvedba čelične konstrukcije ima slijedeće faze:

- izrada elemenata u radionici
- transport od radionice na gradilište
- montaža čelične konstrukcije na gradilištu na prethodno pripremljenu sidrenu konstrukciju (temelje ili dijelove zgrade)

U pravilu se svaka faza mora pregledati i utvrditi da je izvedena prema tehničkoj dokumentaciji i prema važećim tehničkim propisima. Izvršenje fazne kontrole potvrđuju putem zapisnika odgovorne osobe projektanta, stručnog nadzora i izvoditelja. Dok se ne uklone nedostaci utvrđeni u nekoj fazi, ne može započeti iduća faza.

Fazni pregledi sa zapisnicima potpisanim od strane odgovornih imenovanih osoba su:

- kontrola dokaza kvalitete prije početka izrade konstrukcije
- prijem čelične konstrukcije po izradi u radionici
- prijem čelične konstrukcije po transportu na gradilište
- geodetska kontrola montirane čelične konstrukcije
- završni pregled čelične konstrukcije prije početka drugih radova na čeličnoj konstrukciji (pokrivanje, oblaganje, montaža instalacija ili opreme i drugo)

Prigodom prijema u radionici izvođač čelične konstrukcije dužan je staviti na uvid:

- potrebnu tehničku dokumentaciju.
- radioničke nacрте sa specifikacijama
- ateste osnovnog materijala
- ateste dodatnog materijala
- ateste zavarivača
- ateste priključnih elemenata
- dnevnik izrade materijala
- dnevnik zavarivanja
- podatke o tehnologiji zavarivanja
- izvješće interne tehničke kontrole
- uvjerenja o kvalifikacijama stručnih osoba koje sudjeluju u izradi konstrukcije

2.5. PROPISI

Potrebno je pridržavati se svih normi i propisa navedenih u projektu te poštovati pravila dobre izvedbe.

2.6. OPĆE NAPOMENE ZA IZRADU ČELIČNE KONSTRUKCIJE U RADIONICI

Prilikom rezanja materijala treba paziti na mogućnost pojave lokalnih zarez, naročito kod vlačno napregnutih elemenata, Svaki uočeni zarez potrebno je izbrusiti ili dovariti i izbrusiti.

Svi elementi trebaju biti izrađeni u granicama dopuštenih odstupanja. Premaše li odstupanja granične vrijednosti, potrebno je zatražiti suglasnost projektanta na izvedeno stanje.

Kod zavarivačkih radova potrebno je osigurati stalnu kontrolu prije, u toku i nakon izvedenih radova. Površine za zavarivanje moraju biti kvalitetno pripremljene i bez masnoće, rđe i druge prljavštine. Poslije izvedenih radova potrebno je obaviti dimenzionalnu i vizualnu kontrolu te kontrole predviđene projektom. Po potrebi, izvodi se i probno sklapanje o čemu se sastavlja zapisnik, kojega ovjerava nadzorni inženjer. Prilikom izvođenja zavarivačkih radova potrebno je voditi računa da konstrukcija nakon hlađenja ne poprimi neželjeni deformirani oblik. Ne dopušta se zavarivanje na temperaturi nižoj od 0°C.

Za radove koji nakon potpunog sklapanja konstrukcije neće biti vidljivi, radi se zapisnik o preuzimanju u trenutku dostupnosti svih dijelova konstrukcije pregledu.

Dijelovi konstrukcije moraju se prije transporta na gradilište označiti i osigurati od oštećenja prije i u toku transporta na gradilište.

2.7. ELEMENTI KONSTRUKCIJE

Elemente konstrukcije potrebno je izraditi u svemu prema specifikacijama, crtežima i napucima iz ovog dijela projekta.

2.8. ANTIKOROZIVNA ZAŠTITA

Antikorozivnu zaštitu smije se nanositi strogo prema zahtjevima projekta i propisa. Posebnu pažnju treba obratiti na vlažnost zraka i temperaturu. Nakon završene izvedbe svakog sloja potrebno je provjeriti debljinu i prionjivost premaza.

2.9. PROTUPOŽARNA ZAŠTITA

Protupožarnu zaštitu smije se nanositi strogo prema zahtjevima projekta, propisa i uputa proizvođača. Posebnu pažnju treba obratiti na čistoću i suhoću površine. Nakon završene izvedbe svakog sloja potrebno je provjeriti debljinu i prionjivost nanesene zaštite.

2.10. PRIJEM ELEMENATA ČELIČNE KONSTRUKCIJE

Prijem elemenata čelične konstrukcije u radionici obavlja se prije isporuke na gradilište na temelju radioničkih crteža i specifikacije. Prilikom prijema radova potrebno je uz dokumentaciju navedenu u točki 3.1 staviti na uvid i sljedeće:

- radioničke nacрте sa specifikacijama
- dnevnik izrade u radionici
- dnevnik zavarivačkih radova u radionici
- dnevnik izvođenja antikorozivne zaštite
- izvješće interne kontrole o kvaliteti izvedenih radova

Prijem montirane čelične konstrukcije na gradilištu obavlja se na temelju radioničkih crteža i projekta montaže. Prilikom prijema izvedene konstrukcije potrebno je staviti na uvid i sljedeće dokumente:

- kompletnu dokumentaciju sa primopredaje konstrukcije u radionici
- projekt montaže
- radioničke nacрте sa specifikacijama
- dnevnik izvođenja radova na montaži
- dnevnik zavarivačkih radova na montaži
- dnevnik izvođenja antikorozivne zaštite
- izvješće interne kontrole o kvaliteti izvedenih radova
- uvjerenja o kvaliteti dodatnog materijala, sredstava za spajanje te sredstava za antikorozivne i protupožarnu zaštitu
- uvjerenje o podobnosti izvođača za izvođenje radova na montaži
- uvjerenja zavarivača koji će raditi na izradi i montaži konstrukcije za vrstu zavarivačkih radova koja će se primjenjivati, za traženu debljinu, materijal i položaj zavarivanja
- specifikacija postupaka zavarivanja i odobrenje o primjeni postupaka zavarivanja
- uvjerenja o ispravnosti strojeva za izvođenje zavarivačkih radova
- plan izvođenja zavarivačkih radova
- uvjerenje o podobnosti izvođača za izvođenje antikorozivne zaštite
- uvjerenje o podobnosti izvođača za izvođenje protupožarne zaštite
- ovlaštenja svih odgovornih osoba u sustavu interne kontrole izvođača

LISTA PRISTANKA – COMPLIANCE LIST

		LISTA PRISTANKA		Odobrenje za:		Potpis
				Tehnički dio		
				Kvaliteta		
				Tržište		
		Investitor				
		Projekt				
		Oznaka				
		Broj				
		Datum				
Br.	Metoda ili vrsta aktivnosti/ispitivanja	Kriterij pristanka	Način pristanka	Znak	Napomene	
0.0.	JEZIK - OPCENITO	Hrvatski		0		
1.0	PRORAČUN KONSTRUKCIJE					
1.1	Eurocode 3	EN 1993 - 1 - 1		0		
1.2	Eurocode 2	EN 1992 - 1 - 1		0		
1.3	Eurocode 3	EN 1993 - 1 - 2		0		
2.0	DJELOVANJA					
2.1	Vjetra	Brzina vjetra 108 km/h	Po cijeloj visini	Y		
2.2	Snijeg	100 m n. M. I zona		Y		
2.3	Promjena temperaute	+/- 35 °C		Y		
3.0	OSNOVNI MATERIJAL					
3.1	Konstruktivski čelik	EN 10025		0		
3.2	Kvalitetna grupa	S 355 JR G2		0		
4.0	VIJČANI PRIKLJUČCI					
4.1	Kvaliteta materijala za vijke	8.8 ISO 898 - 1		0		
4.2	Matica za vijak	8 ISO 898 - 2		0		
4.3	Podložna pločica			0		
4.4	AKZ - vruća galvanizacija	DIN 267 - Part 10		0		
Ref.				Y	pristanak naručioca	
				N	bez pristanka	
				P	djelomična sugl.	
				0	podrazumjeva se ali bez navoda nar.	

		LISTA PRISTANKA			Odobrenje za:		Potpis
					Tehnički dio		
					Kvaliteta		
					Tržište		
		Investitor					
		Projekt					
		Oznaka					
		Broj					
		Datum					
Br.	Metoda ili vrsta aktivnosti/ispitivanja	Kriterij pristanka	Način pristanka	Znak	Napomene		
5.0	ZAVARENI PRIKLJUČCI						
5.1	Osiguranje kvalitete	EN 729 - 2	uvjerenje/izvještaj	0			
5.2	Kvaliteta - kriterij prihvaćanja	EN 25 817		0			
5.3	Kvaliteta za NDE/UT	EN 1 714	uvjerenje 10%	0			
5.4	Kvaliteta za NDE/MT	EN 1 290	uvjerenje 5%	0			
5.5	Kvaliteta - vizualni pregled	EN 970	100%	0			
5.6	Uvjerenje zavarivača	EN 287 - 1		0			
5.7	Kvaliteta za ispitivanje NDE/PT	EN 1 289		0			
5.8	Kvaliteta za NDE/RK	EN 1 435		0			
6.0	DIMENZIONALNA KONTROLA						
7.0	AKZ - GALVANIZACIJA						
7.1	Priprema površine	ISO 8501		0			
7.2	Metoda ispitivanja	KSB 10/5 - 2.0		0			
7.3	Način kontrole	KSB 10/5 - 2.1		0			
8.0	AKZ - VRUĆE CINČANJE	DIN 267		0			
9.0	DOKUMENTACIJA ZA						
9.1	Općenito	ISO 9001	izvještaj	0			
9.2	Zavarivanje	EN 729 - 2		0			
9.3	Odgovornost za zavarivanje	EN 719	ovlaštenje	0			
10.0	IZRADA I MONTAŽA	ENV 1090 - 1		0			
Ref.				Y	pristanak naručioca		
				N	bez pristanka		
				P	djelomična sugl.		
				0	podrazumjeva se ali bez navoda nar.		

3. ANALIZA DJELOVANJA

3.1. Stalna djelovanja (G)

Primijenjene norme: HRN EN 1991-1-1:2012/NA:2012

3.1.1. Vlastita težina konstrukcije i konstrukcijskih elemenata

- Program *Robot Structural Analysis Professional* automatski izračuna vlastitu težinu

3.1.2. Pokrov

Vlastita težina pokrova

Tip pokrova: sendvič paneli debljine 10 cm

Trimoterm perform C 100

$$g_p = 22,30 \text{ kg/m}^2 = 0,223 \text{ kN/m}^2$$

Fasadni paneli debljine 10 $g_f = 20,90 \text{ kg/m}^2 = 0,209 \text{ kN/m}^2$

- Pokrov i paneli su izabrani iz Trimoterm kataloga [1]

3.1.3. Instalacije

Vlastita težina strojarske opreme i instalacija

$$g_p = 0,5 \text{ kN/m}^2$$

$$g_{uk} = 0,723 \text{ kN/m}^2 + \text{vlastita težina}$$

3.2.Snijeg (Q)

Primijenjene norme: HRN EN 1991-1-3:2012, HRN EN 1991-1-3:2012/NA:2012

Konstrukcija se nalazi na nadmorskoj visini od 30 m u 1. snježnoj zoni prema karti snježnih područja Republike Hrvatske, (Slika 1). Djelovanje snijega na konstrukciju određeno je na temelju norme HRN EN 1991-1-3: 2012 i pripadajućeg nacionalnog dodatka.



Slika 1. Karta snježnih područja [2]

Karakteristično opterećenje očitano je iz Tablice 1.

Tablica 1. Karakteristične vrijednosti proračunskog opterećenja snijegom na tlu [izradio autor, 2]

Nadmorska visina do [m]	1. područje - priobalje i otoci [kN/m ²]	2. područje - zaleđe Dalmacije, Primorja i Istre [kN/m ²]	3. područje - kontinentalna Hrvatska [kN/m ²]	4. područje - gorska Hrvatska [kN/m ²]
100	0,50	0,75	1,00	1,25
200	0,50	0,75	1,25	1,50
300	0,50	0,75	1,50	1,75
400	0,50	1,00	1,75	2,00
500	0,50	1,25	2,00	2,50
600	0,50	1,50	2,25	3,00
700	0,50	2,00	2,50	3,50
800	0,50	2,50	2,75	4,00
900	1,00	3,00	3,00	4,50
1000	2,00	4,00	3,50	5,00
1100	3,00	5,00	4,00	5,50
1200	4,00	6,00	4,50	6,00
1300	5,00	7,00		7,00
1400	6,00	8,00		8,00
1500		9,00		9,00
1600		10,00		10,00
1700		11,00		11,00
1800		12,00		

Karakteristično opterećenje snijegom za nadmorsku visinu do 30 m i 1. područje iznosi:

$$s_k = 0,5 \text{ kN/m}^2$$

Opterećenje snijegom na krovu građevine:

$$s = \mu_i \cdot C_e \cdot C_t \cdot s_k$$

Koeficijent izloženosti

$$C_e = 1.0$$

Toplinski koeficijent

$$C_t = 1.0$$

Koeficijenti oblika opterećenja snijegom na krovu μ_i ovise o nagibu, pa se zbog geometrije krova razmatraju slučajevi višestrukih krovova. Jednaki su kutevi nagiba $\alpha_1 = \alpha_2 = 8^\circ$.

Koeficijenti oblika μ za višestruke krovove prikazani su na slici 2.

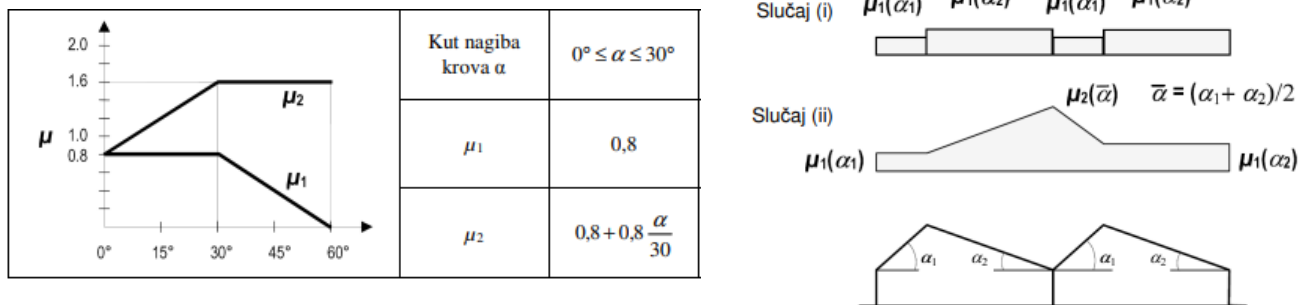

Slika 2. Koeficijenti oblika opterećenja snijegom za višestruke krovove [3]

$$\mu_1(8^\circ) = 0,8$$

$$\mu_2(8^\circ) = 0,8 + 0,8 \cdot \frac{8}{30} = 1,01$$

Slučajevi:

$$s_1 = 0,8 \cdot 1 \cdot 1 \cdot 0,5 = 0,4 \text{ kN/m}^2$$

$$s_2 = 1,01 \cdot 1 \cdot 1 \cdot 0,5 = 0,505 \text{ kN/m}^2$$

Na Slici 3. prikazani su najnepovoljniji slučajevi s vrijednostima opterećenja koje treba razmatrati:

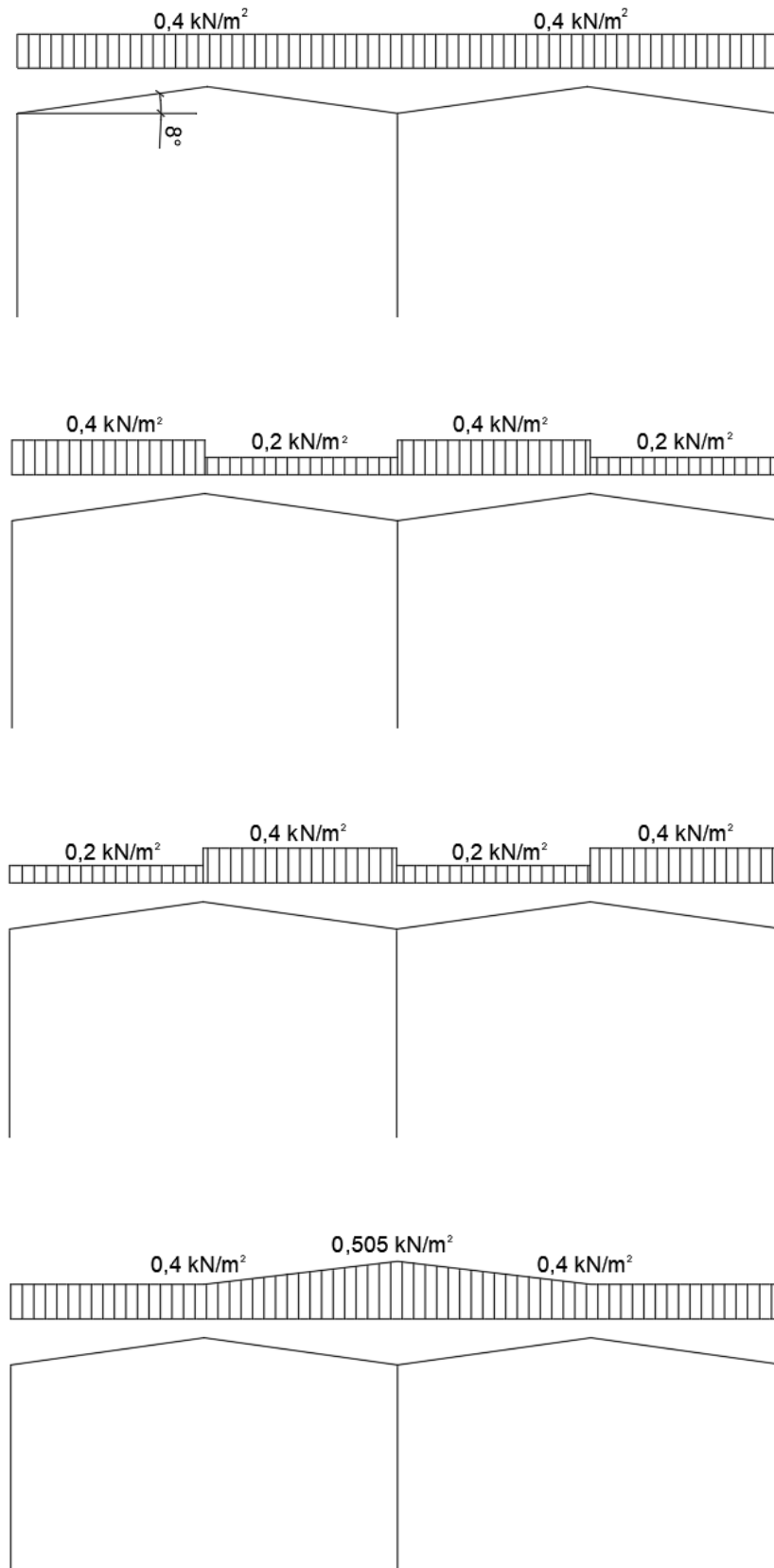

Slika 3. Vrijednosti opterećenja snijegom na krov [izradio autor]

3.3. Vjetar (Q)

Primijenjene norme: HRN EN 1991-1-1-4:2012, HRN EN 1991-1-4:2012/NA:2012

Konstrukcija se nalazi na području terena III. kategorije, a temeljna vrijednost osnovne brzine vjetra $v_{b,0}$ iznosi 30 m/s. Na Slici 4 prikazana je raspodjela brzine vjetra ovisno o lokaciji.



Slika 4. Karta osnovne brzine vjetra $v_{b,0}$ [4]

Proračun osnovne brzina vjetra:

$$v_b = C_{dir} \cdot C_{season} \cdot v_{b,0}$$

Koeficijent smjera djelovanja vjetra, C_{dir} :

$$C_{dir} = 1$$

Koeficijent godišnjeg doba pojave vjetra, C_{season} :

$$C_{season} = 1$$

$$v_b = 1 \cdot 1 \cdot 30 = 30 \text{ m/s}$$

Osnovni pritisak vjetra q_b uslijed brzine v_b :

$$q_b = \frac{1}{2} \cdot \rho_{air} \cdot v_b^2$$

Gustoća zraka, ρ_{air}

$$\rho_{air} = 1.25 \text{ kg/m}^3$$

$$q_b = \frac{1}{2} \cdot 1.25 \cdot 30^2 = 0.563 \text{ kN/m}^2$$

Srednja brzina vjetra:

$$v_m(z) = c_r(z) * c_0(z) * v_b$$

$c_r(z)$ – koeficijent hrapavosti terena

$c_0(z) = 1,0$ – koeficijent orografije

$$c_r(z) = k_r * \ln\left(\frac{z}{z_0}\right), \quad z_{\min} \leq z \leq z_{\max} \quad \text{ili} \quad c_r(z) = c_r(z_{\min}), \quad z < z_{\min}$$

z – visina konstrukcije ili konstrukcijskog elementa

$z_{0,III}$ – visina za teren III. kategorije ($z_{0,III} = 0.3$ m)

z_{\min} – najmanja visina

z_{\max} – najveća visina

Prema Tablici 2, određuju se kategorija i parametri terena.

Tablica 2. Kategorije terena i parametri terena [4]

KATEGORIJA TERENA		z_0 (m)	z_{\min} (m)
0	More ili priobalna područja izložena otvorenom moru	0,003	1
I	Jezera ili ravna i horizontalno položena područja sa zanemarivom vegetacijom i bez prepreka	0,01	1
II	Područja s niskom vegetacijom, npr. travom, i izoliranim preprekama (drveće, zgrade) s razmakom najmanje 20 visina prepreka	0,05	2
III	Područja sa stalnim pokrovom od vegetacije ili zgrada ili područja s izoliranim preprekama s razmakom najviše 20 visina prepreka (npr. sela, predgrađa, stalna šuma)	0,3	5
IV	Područja s najmanje 15 % površine pokrivene zgradama čija prosječna visina premašuje 15 m	1,0	10

Za teren III. kategorije vrijedi:

$$z_{\min} = 5 \text{ m} \quad z_{\max} = 200 \text{ m} \quad z_0 = 0,3 \text{ m}$$

$$z_{\min} < z < z_{\max}; \quad 5 < 11 < 200$$

Koeficijent terena k_r :

k_r – koeficijent terena

$$k_r = 0,19 * \left(\frac{z_0}{z_{0,II}}\right)^{0,07} = 0,19 * \left(\frac{0,3}{0,05}\right)^{0,07} = 0,215$$

Koeficijent hrapavosti terena:

$$c_r(z) = 0,215 * \ln\left(\frac{11}{0,3}\right) = 0,774$$

Srednja brzina vjetra:

$$v_m(z) = 0,774 * 1,0 * 30 = 23,22 \text{ m/s}$$

Intenzitet turbulencije:

$$I_v(z) = \frac{\sigma_v}{v_m(z)} = \frac{k_i}{c_0(z) * \ln\left(\frac{z_{min}}{z_0}\right)},$$

$k_i = 1.0$ – koeficijent turbulencije

$$I_v(z) = \frac{1,0}{1,0 * \ln\left(\frac{11}{0,3}\right)} = 0,278$$

Vršni tlak vjetra $q_p(z)$ na visini z iznad terena:

$$q_p(z) = [1 + 7 * I_v(z)] * \frac{1}{2} * \rho * v_m^2(z)$$

$$q_p(z) = [1 + 7 * 0,278] * \frac{1}{2} * 1,25 * 23,22^2 = 992,74 \frac{\text{N}}{\text{m}^2} = \mathbf{0,993 \text{ kN/m}^2}$$

Koeficijent izloženosti $C_e(z)$ na visini z iznad terena:

$$c_e(z) = \frac{q_p(z)}{q_b} = \frac{0,993}{0,563} = 1,76$$

Prilikom proračuna djelovanja vjetra potrebno je analizirati sljedeće moguće slučajeve:

- 1) Poprečno djelovanje vjetra
- 2) Uzdužno djelovanje vjetra

3.3.1. Slučaj 1. – vanjski transverzalni pritisak, otvori zatvoreni ($\theta = 0^\circ$)**Pogled na zidove vjetrom opterećene građevine**

$$e = \min \left\{ \begin{array}{l} b = 60 \text{ m} \\ 2h = 2 \cdot 12,20 = 24,40 \text{ m} \end{array} \right\} = 24,40 \text{ m}$$

Za slučaj : $e < d$; $24,40 \text{ m} < 33,60 \text{ m}$

Skica poprečnog djelovanja vjetra na vertikalne površine prikazana je na Slici 5.

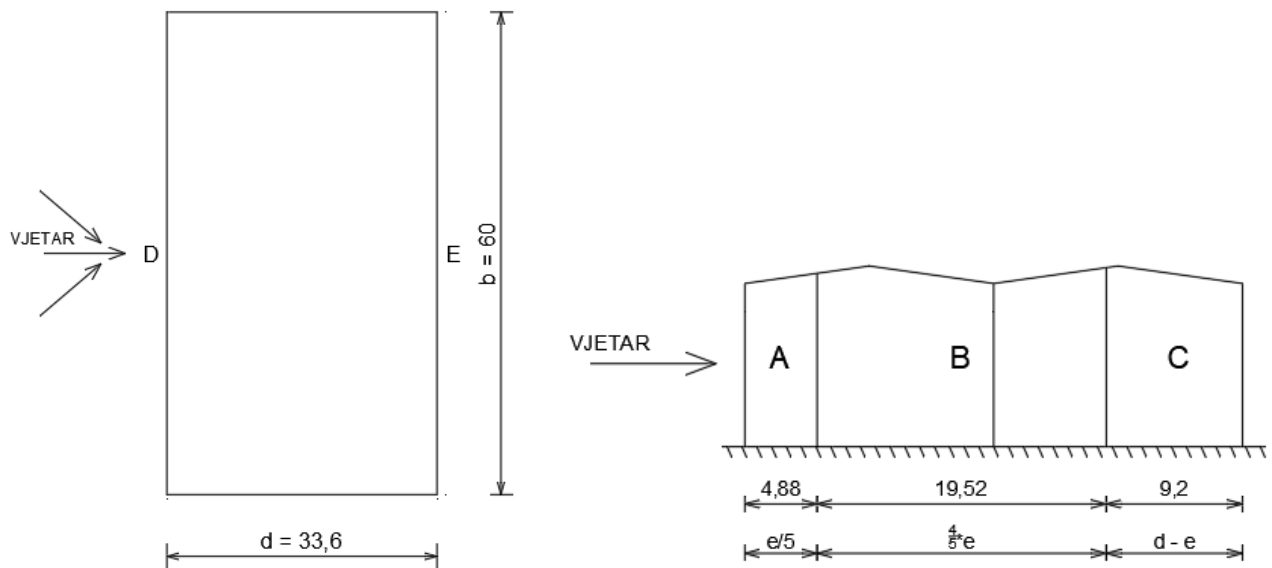

Slika 5. Prikaz zona na vertikalnim površinama pri poprečnom djelovanju vjetra [izradio autor]

Koeficijent vanjskog pritiska c_{pe} ovisi o veličini površine P opterećene zone građevine:

$$c_{pe} = c_{pe,1} \text{ za } P \leq 1 \text{ m}^2$$

$$c_{pe} = c_{pe,1} - (c_{pe,1} - c_{pe,10}) \times \log_{10} P \text{ za } 1 \text{ m}^2 < P \leq 10 \text{ m}^2$$

$$c_{pe} = c_{pe,10} \text{ za } P > 10 \text{ m}^2$$

Koeficijenti vanjskog pritiska c_{pe} :

$$h/d = 12,20/33,60 = 0,37 \quad 0,25 < 0,37 < 1$$

$$P_A = 57,31 \text{ m}^2 > 10 \text{ m}^2 \rightarrow c_{pe,A} = c_{pe,10} = -1,2$$

$$P_B = 235,10 \text{ m}^2 > 10 \text{ m}^2 \rightarrow c_{pe,B} = c_{pe,10} = -0,8$$

$$P_C = 104,07 \text{ m}^2 > 10 \text{ m}^2 \rightarrow c_{pe,C} = c_{pe,10} = -0,5$$

$$P_D = 660 \text{ m}^2 > 10 \text{ m}^2 \rightarrow c_{pe,D} = c_{pe,10} = +0,716$$

$$P_E = 660 \text{ m}^2 > 10 \text{ m}^2 \rightarrow c_{pe,E} = c_{pe,10} = -0,332$$

Koeficijenti unutarnjeg pritiska $c_{pi} = 0$ (otvori zatvoreni)

Opterećenje na vertikalne plohe uslijed djelovanja vjetra, w :

$$w = w_{e,i} - w_i = q_p(z) \cdot (c_{pe,i} - c_{pi})$$

$$w_A = w_{e,A} - w_i = 0,974 \cdot (-1,2 - 0) = -1,169 \text{ kN/m}^2$$

$$w_B = w_{e,B} - w_i = 0,974 \cdot (-0,8 - 0) = -0,779 \text{ kN/m}^2$$

$$w_C = w_{e,C} - w_i = 0,974 \cdot (-0,5 - 0) = -0,487 \text{ kN/m}^2$$

$$w_D = w_{e,D} - w_i = 0,974 \cdot (+0,761 - 0) = +0,697 \text{ kN/m}^2$$

$$w_E = w_{e,E} - w_i = 0,974 \cdot (-0,332 - 0) = -0,314 \text{ kN/m}^2$$

Pogled na višestrešni krov

Po Eurokodu 4, kod višestrukih krovova vjetar se određuje prema slici 6. Koeficijenti C_{pe} se razlikuju i određuju za jednostrešne i dvostrešne krovove. Prvi nagib krova se uzima kao jednostrešni, ostali nagibi kao dvostrešni, te će se tako i promatrati u nastavku.

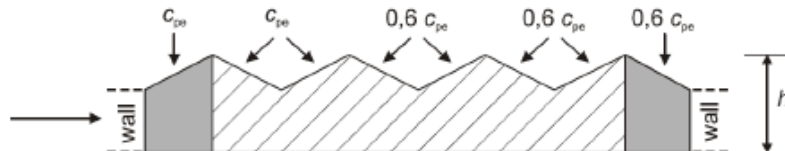

Slika 6. Koeficijenti kod višestrešnih krovova [4]

Jednostrešni krov - prvi nagib

Na Slici 7. prikazano je djelovanje vjetra kod slučaja jednostrešnih krovova.

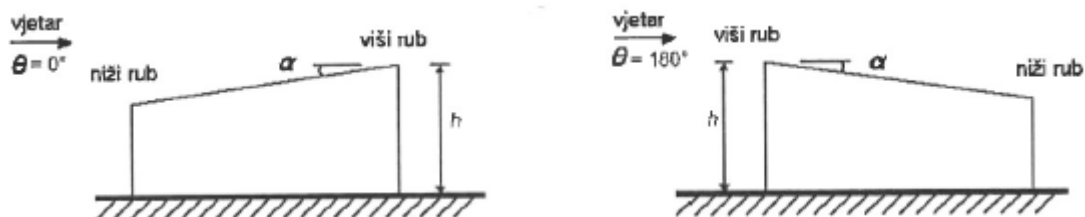

Slika 7. Djelovanje vjetra na jednostrešni krov za 0° i 180° [4]

Raspodjela zona na krovu kod poprečnog djelovanja vjetrom prikazana je na Slici 8.

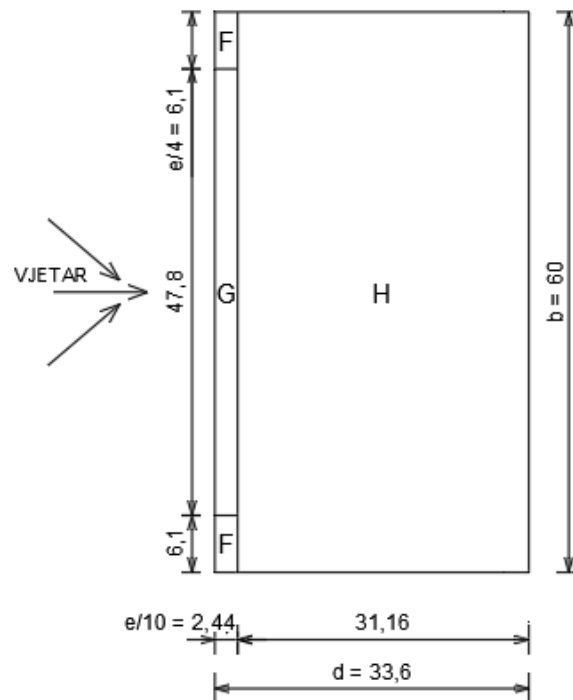

Slika 8. Raspodjela zona na 'jednostrešnom' krovu pri poprečnom djelovanju vjetra [izradio autor]

Površine krovnih ploha i koeficijenti vanjskog pritiska c_{pe} :

$$h/d = 12,40/33,6 = 0,37 \quad 0,25 < 0,37 < 1$$

$$P_F = 31,06 \text{ m}^2 > 10 \text{ m}^2 \rightarrow c_{pe,F1} = -1,46 ; c_{pe,F2} = +0,06$$

$$P_G = 119,24 \text{ m}^2 > 10 \text{ m}^2 \rightarrow c_{pe,G1} = -1,08 ; c_{pe,G2} = +0,06$$

$$P_H = 1886,4 \text{ m}^2 > 10 \text{ m}^2 \rightarrow c_{pe,H1} = -0,51 ; c_{pe,H2} = +0,06$$

Koeficijenti unutarnjeg pritiska $c_{pi} = 0$ (otvori zatvoreni)

Opterećenje na krovne plohe uslijed djelovanja vjetra, w :

$$w = w_{e,i} - w_i = q_p(z) \cdot (c_{pe,i} - c_{pi})$$

$$w_{F1} = w_{e,F1} - w_i = 0,974 \cdot (-1,46 - 0) = -1,42 \text{ kN/m}^2$$

$$w_{F2} = w_{e,F2} - w_i = 0,974 \cdot (0,06 - 0) = 0,058 \text{ kN/m}^2$$

$$w_{G1} = w_{e,G1} - w_i = 0,974 \cdot (-1,08 - 0) = -1,05 \text{ kN/m}^2$$

$$w_{G2} = w_{e,G2} - w_i = 0,974 \cdot (0,06 - 0) = 0,058 \text{ kN/m}^2$$

$$w_{H1} = w_{e,H1} - w_i = 0,974 \cdot (-0,51 - 0) = -0,50 \text{ kN/m}^2$$

$$w_{H2} = w_{e,H2} - w_i = 0,974 \cdot (0,06 - 0) = 0,058 \text{ kN/m}^2$$

Dvostrešni krov

Na Slici 9. prikazano je djelovanje vjetra kod slučaja dvostrešnih krovova.

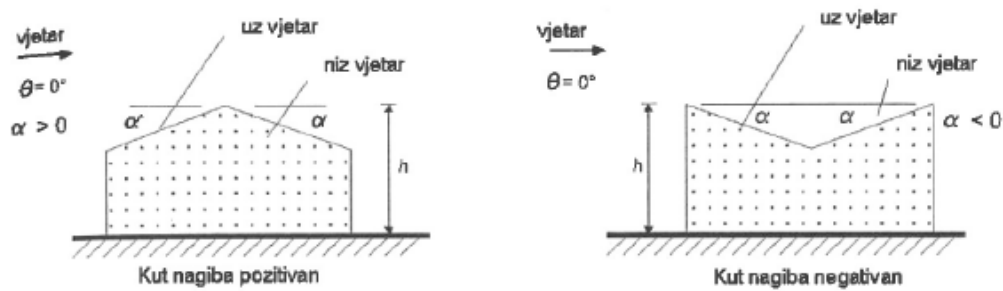

Slika 9. Djelovanje vjetra na dvostrešni krov [4]

Kut nagiba α uzima se po desnom slučaju slike 9, sa negativnim predznakom.

Na Slici 10. prikazana je raspodjela zona na krovu pri poprečnom djelovanju vjetra.

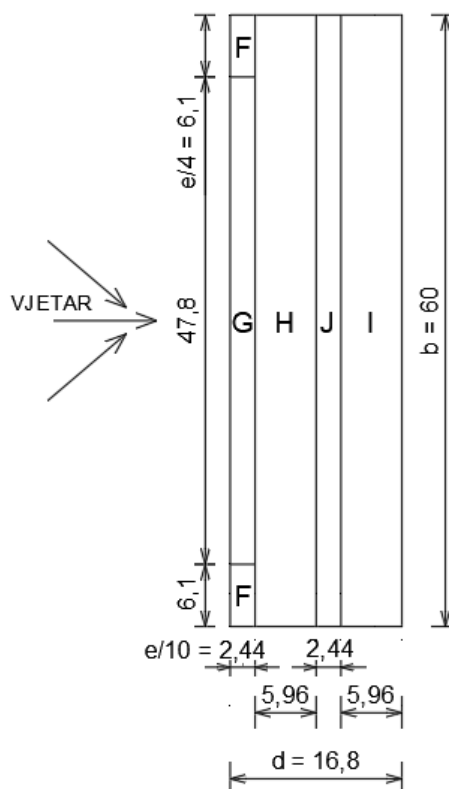

Slika 10. Raspodjela zona na krovu pri poprečnom djelovanju vjetrom [izradió autor]

Površine krovnih ploha i koeficijenti vanjskog pritiska c_{pe} :

$$P_F = 31,06 \text{ m}^2 > 10 \text{ m}^2 \rightarrow c_{pe,F1} = - 2,36$$

$$P_G = 119,24 \text{ m}^2 > 10 \text{ m}^2 \rightarrow c_{pe,G1} = - 1,23$$

$$P_H = 358,8 \text{ m}^2 > 10 \text{ m}^2 \rightarrow c_{pe,H1} = - 0,83$$

$$P_I = 150,3 \text{ m}^2 > 10 \text{ m}^2 \rightarrow c_{pe,I1} = - 0,57 ; c_{pe,I2} = - 0,01$$

$$P_J = 358,8 \text{ m}^2 > 10 \text{ m}^2 \rightarrow c_{pe,J1} = - 0,63 ; c_{pe,J2} = - 0,07$$

Koeficijenti unutarnjeg pritiska $c_{pi} = 0$ (otvori zatvoreni)

Opterećenje na krovne plohe uslijed djelovanja vjetra, w :

$$w = w_{e,i} - w_i = q_p(z) \cdot (c_{pe,i} - c_{pi})$$

$$w_{F1} = w_{e,F1} - w_i = 0,974 \cdot (- 2,36 - 0) = - 2,30 \text{ kN/m}^2$$

$$w_{G1} = w_{e,G1} - w_i = 0,974 \cdot (- 1,23 - 0) = - 1,20 \text{ kN/m}^2$$

$$w_{H1} = w_{e,H1} - w_i = 0,974 \cdot (- 0,83 - 0) = - 0,81 \text{ kN/m}^2$$

$$w_{I1} = w_{e,I1} - w_i = 0,974 \cdot (- 0,57 - 0) = - 0,56 \text{ kN/m}^2$$

$$w_{I2} = w_{e,I2} - w_i = 0,974 \cdot (- 0,01 - 0) = - 0,01 \text{ kN/m}^2$$

$$w_{J1} = w_{e,J1} - w_i = 0,974 \cdot (- 0,63 - 0) = - 0,61 \text{ kN/m}^2$$

$$w_{J2} = w_{e,J2} - w_i = 0,974 \cdot (- 0,07 - 0) = - 0,07 \text{ kN/m}^2$$

Grafički prikaz opterećenja vjetra ($\theta = 0^\circ$)

Na slikama 11., 11.1., i 11.2. dan je grafički prikaz opterećenja pri poprečnom djelovanju vjetra sa zatvorenim otvorima.

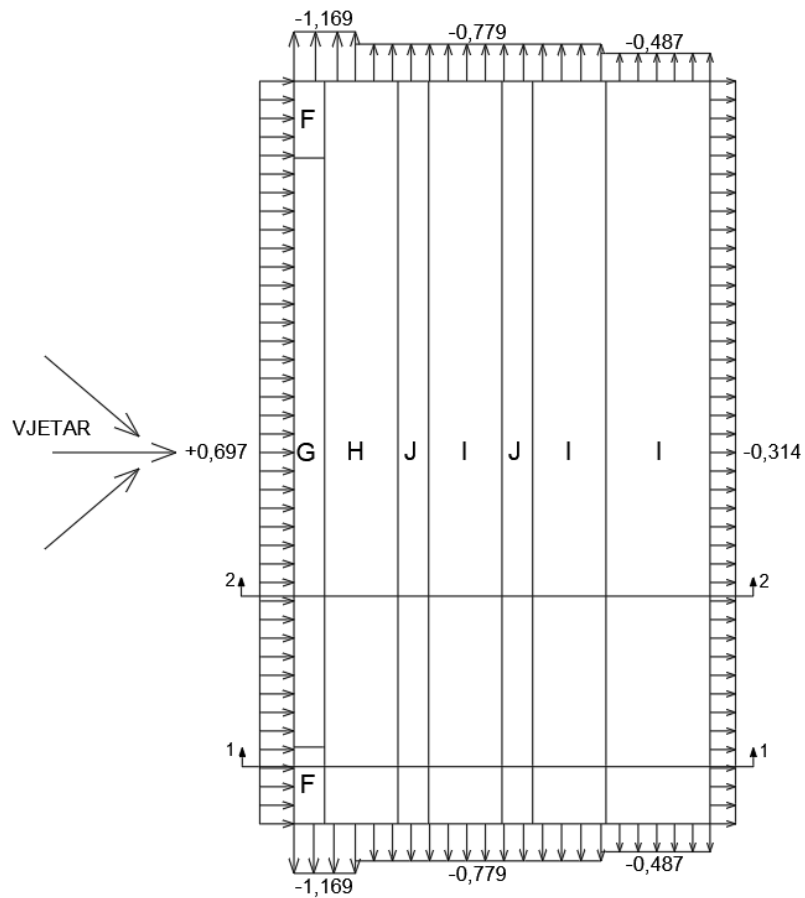

Slika 11. Djelovanje vjetra za slučaj 1 [izradio autor]

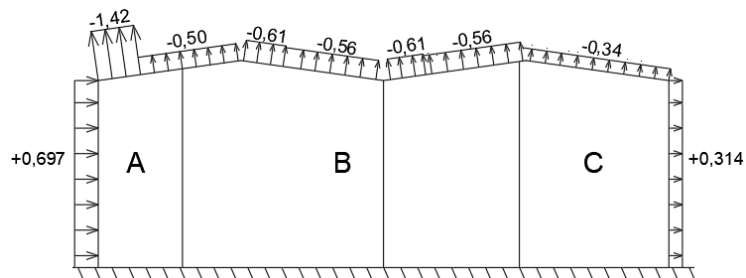

Slika 11.1. Presjek 1 – 1 - MJERODAVAN [izradio autor]

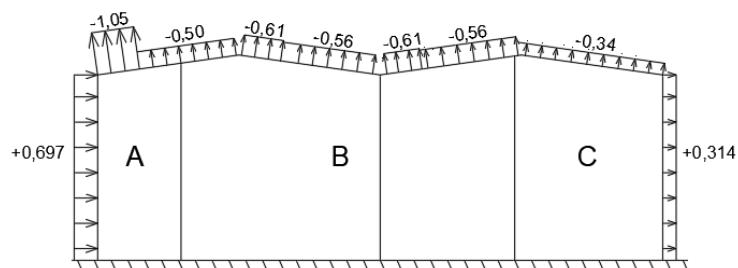

Slika 11.2. Presjek 2 – 2 [izradio autor]

4.1.1. Slučaj 2. – vanjski transverzalni pritisak, otvori otvoreni ($\theta = 0^\circ$)Pritisak vjetra na unutarnje plohe:

Otvori na konstrukciji:

Na kraćim stranama (zabatima): - 4 vrata za ulaz/izlaz vozila i strojeva, 5,0 x 4,0 m

Na dužim stranama: - 4 vrata za prolaz ljudi, 2,0 x 1,0 m
 -20 prozora sa svake strane od kojih se svaki drugi otvara,
 (1,5 x 1 m)

$$h/d = 12,20/33,60 = 0,37$$

$$\mu = \frac{\sum \text{površina otvora gdje je } c_{pe} \text{ negativan}}{\sum \text{ukupna površina otvora}} = \frac{(5 \cdot 4) \times 4 + (2 \cdot 1) \times 2 + (1,5 \cdot 1) \times 10}{(5 \cdot 4) \times 4 + (2 \cdot 1) \times 4 + (1,5 \cdot 1) \times 20} = \frac{99 \text{ m}^2}{118 \text{ m}^2} = 0,84$$

Koeficijent c_{pi} unutarnjeg pritiska vjetra određen je preko grafa prikazanog na Slici 12.

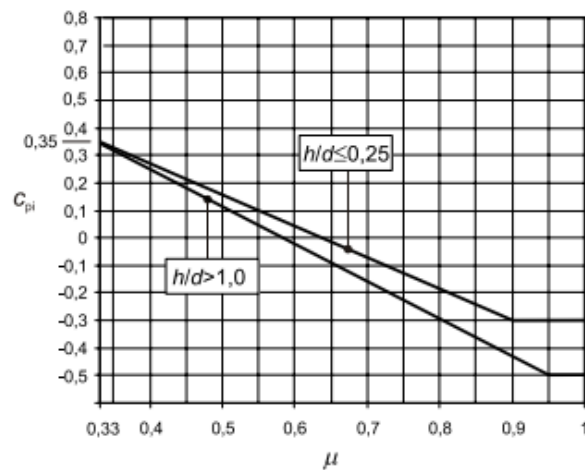
Slika 12. c_{pi} unutarnjeg pritiska vjetra [4]

Koeficijent unutarnjeg pritiska određen iz slike 12. iznosi $\rightarrow c_{pi} = - 0,25$

Opterećenje na vertikalne plohe uslijed djelovanja vjetra, w :

$$w = w_{e,i} - w_i = q_p(z) \cdot (c_{pe,i} - c_{pi})$$

$$w_A = w_{e,A} - w_i = 0,974 \cdot (-1,2 + 0,25) = -0,925 \text{ kN/m}^2$$

$$w_B = w_{e,B} - w_i = 0,974 \cdot (-0,8 + 0,25) = -0,536 \text{ kN/m}^2$$

$$w_C = w_{e,C} - w_i = 0,974 \cdot (-0,5 + 0,25) = -0,244 \text{ kN/m}^2$$

$$w_D = w_{e,D} - w_i = 0,974 \cdot (+0,761 + 0,25) = +0,985 \text{ kN/m}^2$$

$$w_E = w_{e,E} - w_i = 0,974 \cdot (-0,332 + 0,25) = -0,080 \text{ kN/m}^2$$

Opterećenje na krovne plohe jednostrešnog krova uslijed djelovanja vjetra, w :

$$w = w_{e,i} - w_i = q_p(z) \cdot (c_{pe,i} - c_{pi})$$

$$w_{F1} = w_{e,F1} - w_i = 0,974 \cdot (-1,46 + 0,25) = -1,18 \text{ kN/m}^2$$

$$w_{F2} = w_{e,F2} - w_i = 0,974 \cdot (0,06 + 0,25) = 0,302 \text{ kN/m}^2$$

$$w_{G1} = w_{e,G1} - w_i = 0,974 \cdot (-1,08 + 0,25) = -0,81 \text{ kN/m}^2$$

$$w_{G2} = w_{e,G2} - w_i = 0,974 \cdot (0,06 + 0,25) = 0,302 \text{ kN/m}^2$$

$$w_{H1} = w_{e,H1} - w_i = 0,974 \cdot (-0,51 + 0,25) = -0,25 \text{ kN/m}^2$$

$$w_{H2} = w_{e,H2} - w_i = 0,974 \cdot (0,06 + 0,25) = 0,302 \text{ kN/m}^2$$

Opterećenje na krovne plohe dvostrešnog krova uslijed djelovanja vjetra, w :

$$w = w_{e,i} - w_i = q_p(z) \cdot (c_{pe,i} - c_{pi})$$

$$w_{F1} = w_{e,F1} - w_i = 0,974 \cdot (-2,36 + 0,25) = -2,06 \text{ kN/m}^2$$

$$w_{G1} = w_{e,G1} - w_i = 0,974 \cdot (-1,23 + 0,25) = -0,95 \text{ kN/m}^2$$

$$w_{H1} = w_{e,H1} - w_i = 0,974 \cdot (-0,83 + 0,25) = -0,56 \text{ kN/m}^2$$

$$w_{I1} = w_{e,I1} - w_i = 0,974 \cdot (-0,57 + 0,25) = -0,31 \text{ kN/m}^2$$

$$w_{I2} = w_{e,I2} - w_i = 0,974 \cdot (-0,01 + 0,25) = 0,23 \text{ kN/m}^2$$

$$w_{J1} = w_{e,J1} - w_i = 0,974 \cdot (-0,63 + 0,25) = -0,37 \text{ kN/m}^2$$

$$w_{J2} = w_{e,J2} - w_i = 0,974 \cdot (-0,07 + 0,25) = -0,07 \text{ kN/m}^2$$

Grafički prikaz opterećenja vjetra

Na slikama 13., 13.1. i 13.2. dan je grafički prikaz opterećenja pri poprečnom djelovanju vjetra s otvorenim otvorima.

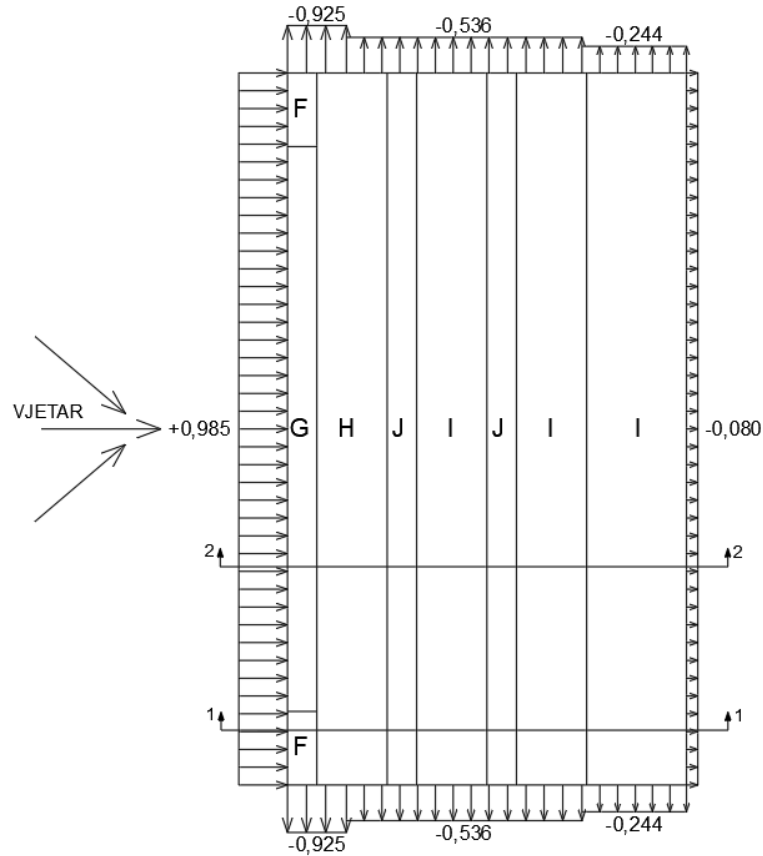

Slika 13. Djelovanje vjetra za slučaj 2 [izradio autor]

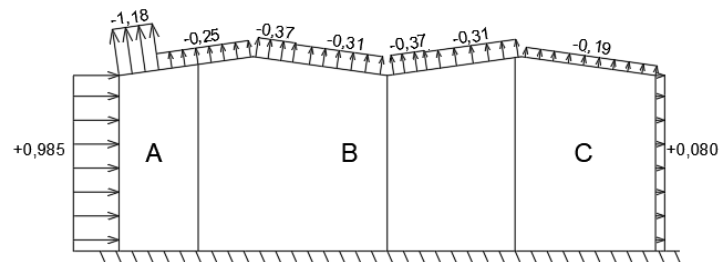

Slika 13.1. Presjek 1 – 1 - MJERODAVAN [izradio autor]

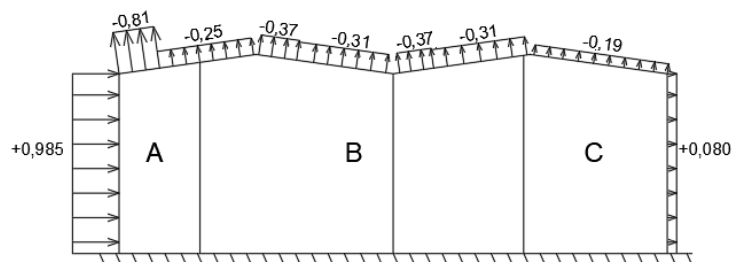

Slika 13.2. Presjek 1 – 1 [izradio autor]

4.1.2. Slučaj 3. – vanjski longitudinalni pritisak, otvori zatvoreni ($\theta = 90^\circ$)**Pogled na zidove vjetrom opterećene građevine**

$$e = \min \left\{ \begin{array}{l} b = 33,60 \text{ m} \\ 2h = 2 \cdot 12,20 = 24,40 \text{ m} \end{array} \right\} = 24,40 \text{ m}$$

Za slučaj : $e < d$; $24,40 \text{ m} < 33,60 \text{ m}$

Skica uzdužnog djelovanja vjetra na vertikalne površine prikazana je na Slici 14.

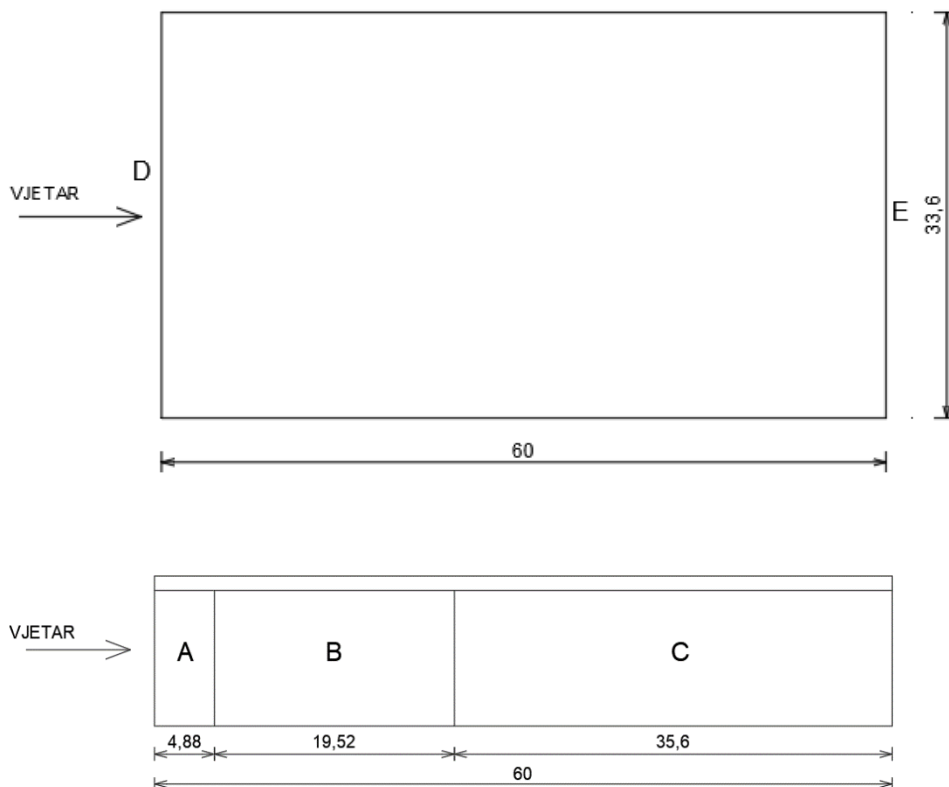

Slika 14. Prikaz zona na vertikalnim površinama pri uzdužnom djelovanju vjetra [izradio autor]

Koeficijenti vanjskog pritiska c_{pe} :

$$h/d = 12,20/60 = 0,20 \quad 0,20 < 0,25$$

$$P_A = 53,68 \text{ m}^2 > 10 \text{ m}^2 \rightarrow c_{pe,A} = c_{pe,10} = -1,2$$

$$P_B = 214,72 \text{ m}^2 > 10 \text{ m}^2 \rightarrow c_{pe,B} = c_{pe,10} = -0,8$$

$$P_C = 391,96 \text{ m}^2 > 10 \text{ m}^2 \rightarrow c_{pe,C} = c_{pe,10} = -0,5$$

$$P_D = 389,43 \text{ m}^2 > 10 \text{ m}^2 \rightarrow c_{pe,D} = c_{pe,10} = +0,7$$

$$P_E = 384,43 \text{ m}^2 > 10 \text{ m}^2 \rightarrow c_{pe,E} = c_{pe,10} = -0,3$$

Koeficijenti unutarnjeg pritiska $c_{pi} = 0$ (otvori zatvoreni)

Opterećenje na vertikalne plohe uslijed djelovanja vjetra, w :

$$w = w_{e,i} - w_i = q_p(z) \cdot (c_{pe,i} - c_{pi})$$

$$w_A = w_{e,A} - w_i = 0,974 \cdot (-1,2 - 0) = -1,17 \text{ kN/m}^2$$

$$w_B = w_{e,B} - w_i = 0,974 \cdot (-0,8 - 0) = -0,78 \text{ kN/m}^2$$

$$w_C = w_{e,C} - w_i = 0,974 \cdot (-0,5 - 0) = -0,49 \text{ kN/m}^2$$

$$w_D = w_{e,D} - w_i = 0,974 \cdot (+0,7 - 0) = +0,68 \text{ kN/m}^2$$

$$w_E = w_{e,E} - w_i = 0,974 \cdot (-0,3 - 0) = -0,29 \text{ kN/m}^2$$

Pogled na višestrešni krov

$$e = \min \left\{ \begin{array}{l} b = 33,60 \text{ m} \\ 2h = 2 \cdot 12,20 = 24,40 \text{ m} \end{array} \right\} = 24,40 \text{ m}$$

$$e < d; \quad 24,40 \text{ m} < 33,60 \text{ m}$$

Na slici 15. dan je prikaz raspodjela zona na krovu pri uzdužnom djelovanju vjetra.

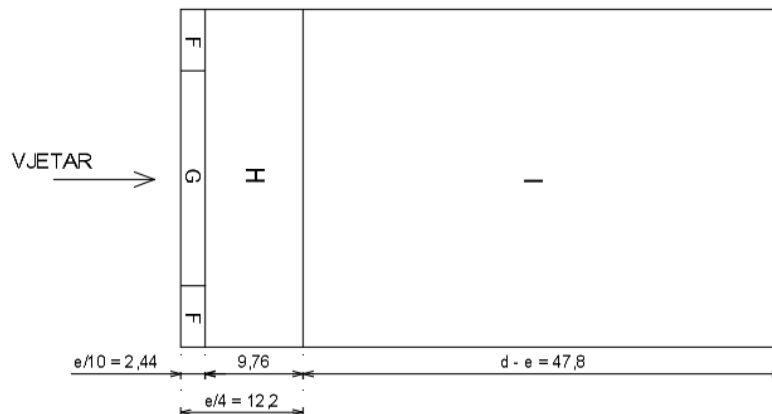

Slika 15. Pogled na krov pri uzdužnom djelovanju vjetra [izradio autor]

Koeficijenti vanjskog pritiska c_{pe} :

$$P_{F,up} = 15,03 \text{ m}^2 > 10 \text{ m}^2 \rightarrow c_{pe,F} = -2,19$$

$$P_{F,low} = 15,03 \text{ m}^2 > 10 \text{ m}^2 \rightarrow c_{pe,F} = -1,95$$

$$P_G = 52,73 \text{ m}^2 > 10 \text{ m}^2 \rightarrow c_{pe,G} = -1,83$$

$$P_H = 331,16 \text{ m}^2 > 10 \text{ m}^2 \rightarrow c_{pe,H} = -0,66$$

$$P_I = 1621,85 \text{ m}^2 > 10 \text{ m}^2 \rightarrow c_{pe,I} = -0,56$$

Koeficijenti unutarnjeg pritiska $c_{pi} = 0$ (otvori zatvoreni)

Opterećenje na krovne plohe uslijed djelovanja vjetra, w :

$$w = w_{e,i} - w_i = q_p(z) \cdot (c_{pe,i} - c_{pi})$$

$$w_{F,up} = w_{e,F} - w_i = 0,974 \cdot (-2,19 - 0) = -2,13 \text{ kN/m}^2$$

$$w_{F,low} = w_{e,F} - w_i = 0,974 \cdot (-1,95 - 0) = -1,90 \text{ kN/m}^2$$

$$w_G = w_{e,G} - w_i = 0,974 \cdot (-1,83 - 0) = -1,78 \text{ kN/m}^2$$

$$w_H = w_{e,H} - w_i = 0,974 \cdot (-0,66 - 0) = -0,64 \text{ kN/m}^2$$

$$w_I = w_{e,I} - w_i = 0,974 \cdot (-0,56 - 0) = -0,55 \text{ kN/m}^2$$

Grafički prikaz opterećenja vjetra ($\theta = 90^\circ$)

Na slikama 16., 16.1., dan je grafički prikaz opterećenja pri uzdužnom djelovanju vjetra sa zatvorenim otvorima.

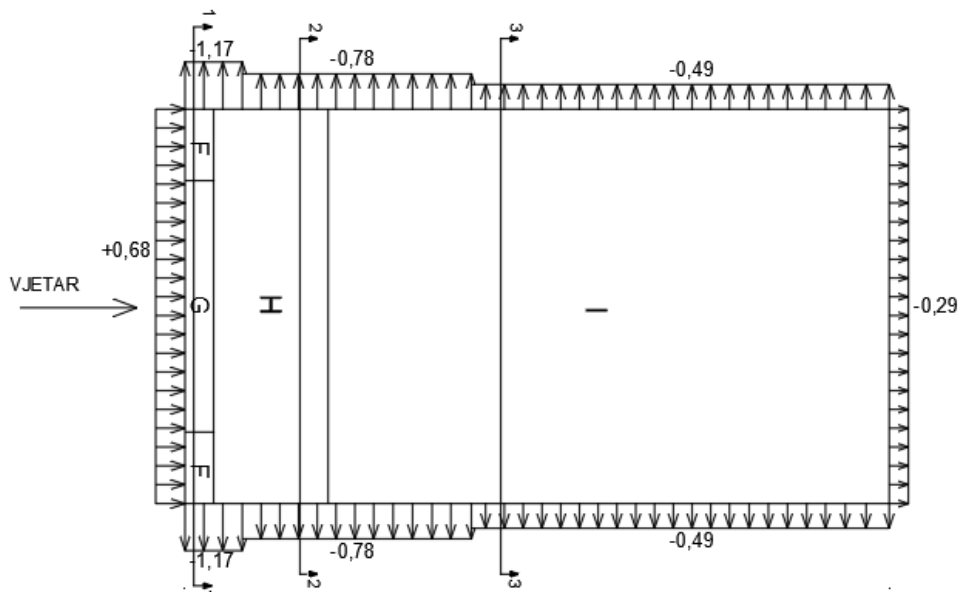

Slika 16. Djelovanje vjetra za slučaj 3 [izradio autor]

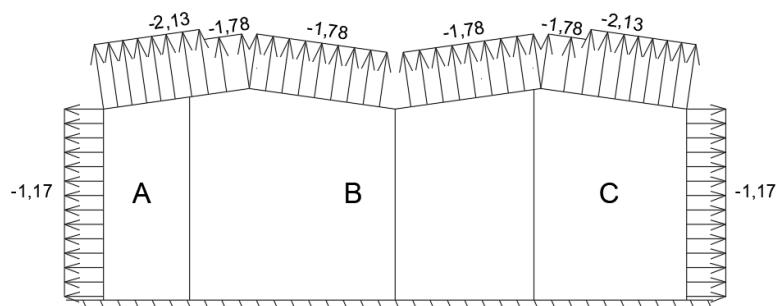

Slika 16.1. Presjek 1 - 1 – MJERODAVAN [izradio autor]

4.1.1. Slučaj 4. – vanjski longitudinalni pritisak, otvori otvoreni ($\theta = 90^\circ$)Pritisak vjetra na unutarnje plohe:

Otvori na konstrukciji:

Na kraćim stranama (zabatima): - 4 vrata za ulaz/izlaz vozila i strojeva, 5,0 x 4,0 m

Na dužim stranama: - 4 vrata za prolaz ljudi, 2,0 x 1,0 m
 -20 prozora sa svake strane od kojih se svaki drugi otvara,
 (1,5 x 1 m)

$$h/d = 12,20/33,60 = 0,37$$

$$\mu = \frac{\sum \text{površina otvora gdje je } c_{pe} \text{ negativan}}{\sum \text{ukupna površina otvora}} = \frac{(5 \cdot 4) \times 4 + (2 \cdot 1) \times 2 + (1,5 \cdot 1) \times 10}{(5 \cdot 4) \times 4 + (2 \cdot 1) \times 4 + (1,5 \cdot 1) \times 20} = \frac{99 \text{ m}^2}{118 \text{ m}^2} = 0,84$$

Koeficijent unutarnjeg pritiska, $c_{pi} = - 0,25$ Opterećenje na vertikalne plohe uslijed djelovanja vjetra, w :

$$w = w_{e,i} - w_i = q_p(z) \cdot (c_{pe,i} - c_{pi})$$

$$w_A = w_{e,A} - w_i = 0,974 \cdot (- 1,2 + 0,25) = - 0,925 \text{ kN/m}^2$$

$$w_B = w_{e,B} - w_i = 0,974 \cdot (- 0,8 + 0,25) = - 0,536 \text{ kN/m}^2$$

$$w_C = w_{e,C} - w_i = 0,974 \cdot (- 0,5 + 0,25) = - 0,244 \text{ kN/m}^2$$

$$w_D = w_{e,D} - w_i = 0,974 \cdot (+ 0,7 + 0,25) = + 0,925 \text{ kN/m}^2$$

$$w_E = w_{e,E} - w_i = 0,974 \cdot (- 0,3 + 0,25) = - 0,050 \text{ kN/m}^2$$

Opterećenje na krovne plohe višestrešnog krova uslijed djelovanja vjetra, w :

$$w = w_{e,i} - w_i = q_p(z) \cdot (c_{pe,i} - c_{pi})$$

$$w_{F,up} = w_{e,F,up} - w_i = 0,974 \cdot (- 2,19 + 0,25) = - 1,89 \text{ kN/m}^2$$

$$w_{F,low} = w_{e,F,low} - w_i = 0,974 \cdot (- 1,95 + 0,25) = - 1,66 \text{ kN/m}^2$$

$$w_G = w_{e,G} - w_i = 0,974 \cdot (- 1,83 + 0,25) = - 1,54 \text{ kN/m}^2$$

$$w_H = w_{e,H} - w_i = 0,974 \cdot (- 0,66 + 0,25) = - 0,40 \text{ kN/m}^2$$

$$w_I = w_{e,I} - w_i = 0,974 \cdot (- 0,56 + 0,25) = - 0,30 \text{ kN/m}^2$$

Grafički prikaz opterećenja vjetra ($\theta = 90^\circ$)

Na slikama 17., 17.1., dan je grafički prikaz opterećenja pri uzdužnom djelovanju vjetra s otvorenim otvorima.

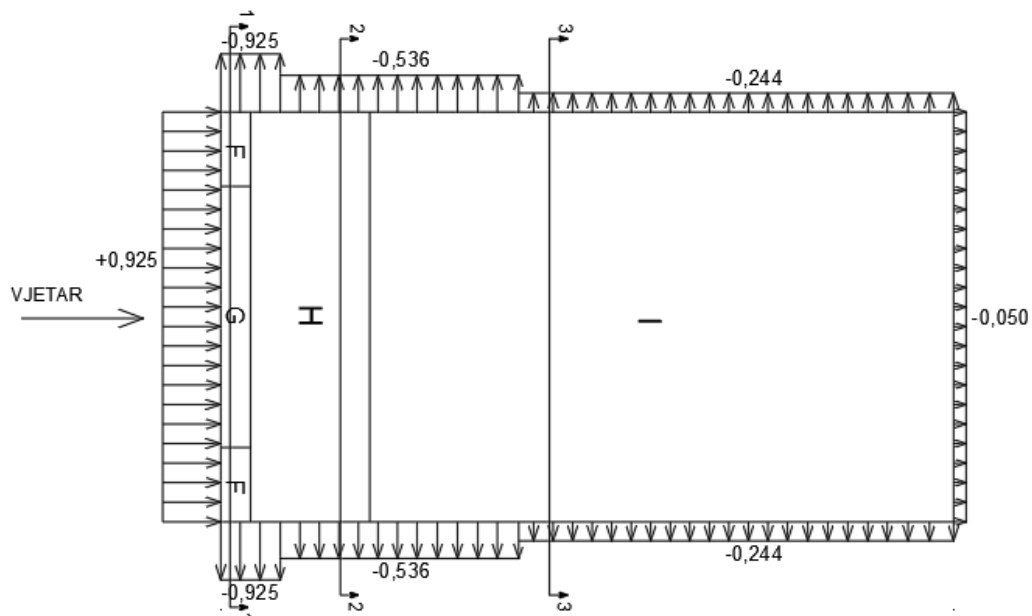

Slika 17. Djelovanje vjetra za slučaj 4 [izradio autor]

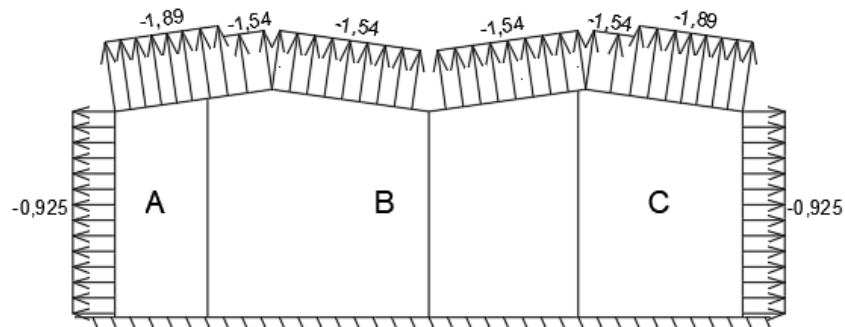

Slika 17.1. Presjek 1 – 1 - MJERODAVAN [izradio autor]

3.4. Opterećenje kranom

Duž hale djeluju dvije dizalice različite nosivosti, jedna od 5,0 t, druga od 16 t. Raspona su 16 metara, te se tom podatku prilagodilo projektiranje konstrukcije. Potrebno je očitati međusobni razmak kotača i maksimalnu te minimalnu vertikalnu silu na kotač iz koje se potom izračunaju potrebne horizontalne sile kočenja. Poprečna sila kao 7% vertikalne sile, a uzdužna sila kao 14% vertikalne. Vrijednosti sila prikazane su u tablicama 3 i 4.

Tablica 3. Podatci djelovanja dizalice od 5 t po jednom kotaču [5]

Opterećenje nosivosti dizalice od 5 t po jednom kotaču			
Maksimalna vertikalna sila	$R_{v,max}$	35,5	kN
Minimalna vertikalna sila	$R_{v,min}$	10,4	kN
Maksimalna poprečna sila	$R_{p,max}$	2,84	kN
Minimalna poprečna sila	$R_{p,min}$	0,832	kN
Maksimalna uzdužna sila	$R_{u,max}$	4,97	kN
Minimalna uzdužna sila	$R_{u,min}$	1,456	kN
Razmak kotača	R	2700	mm

Tablica 4. Podatci djelovanja dizalice od 16 t po jednom kotaču [5]

Opterećenje nosivosti dizalice od 16 t po jednom kotaču			
Maksimalna vertikalna sila	$R_{v,max}$	97,9	kN
Minimalna vertikalna sila	$R_{v,min}$	21,1	kN
Maksimalna poprečna sila	$R_{p,max}$	7,832	kN
Minimalna poprečna sila	$R_{p,min}$	1,688	kN
Maksimalna uzdužna sila	$R_{u,max}$	13,706	kN
Minimalna uzdužna sila	$R_{u,min}$	2,954	kN
Razmak kotača	R	2900	mm

Karakteristični položaji dizalica

Na Slikama 18. – 29. prikazani su promatrani karakteristični položaji dizalica

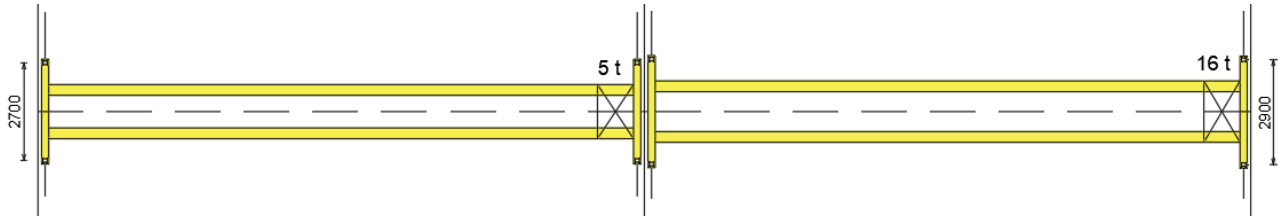

Slika 18. Položaj 1 [izradio autor]

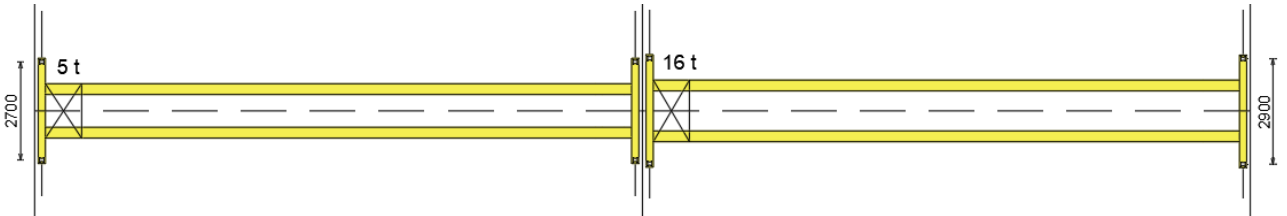

Slika 19. Položaj 2 [izradio autor]

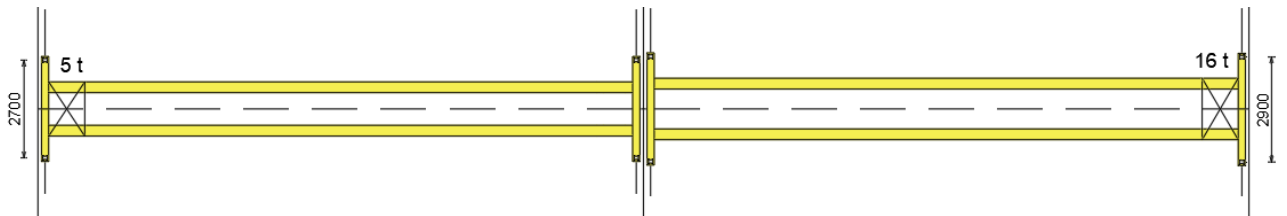

Slika 20. Položaj 3 [izradio autor]

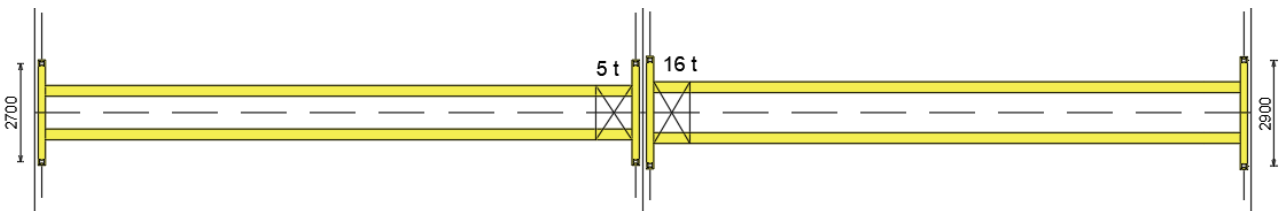

Slika 21. Položaj 4 [izradio autor]

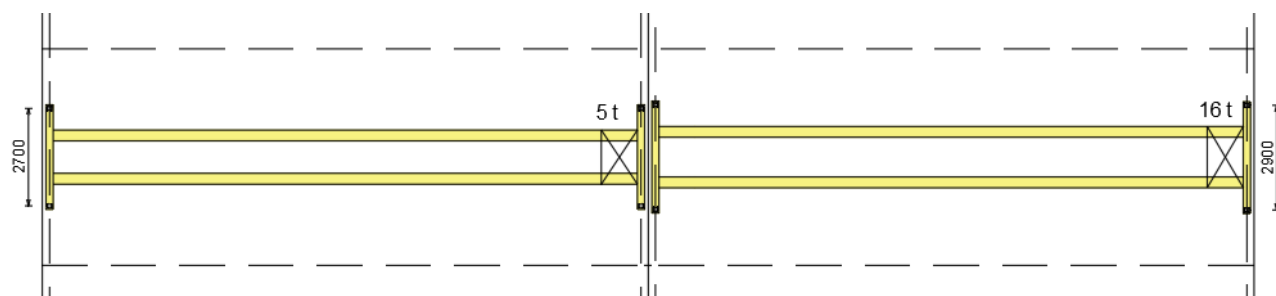

Slika 22. Položaj 5 [izradio autor]

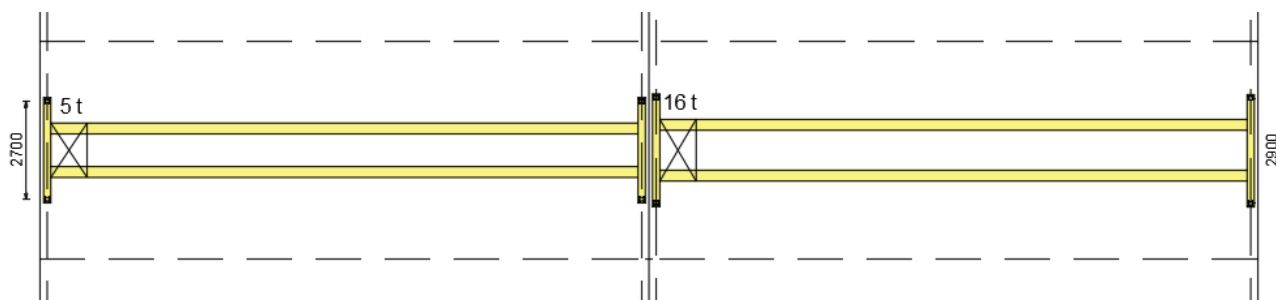

Slika 23. Položaj 6 [izradio autor]

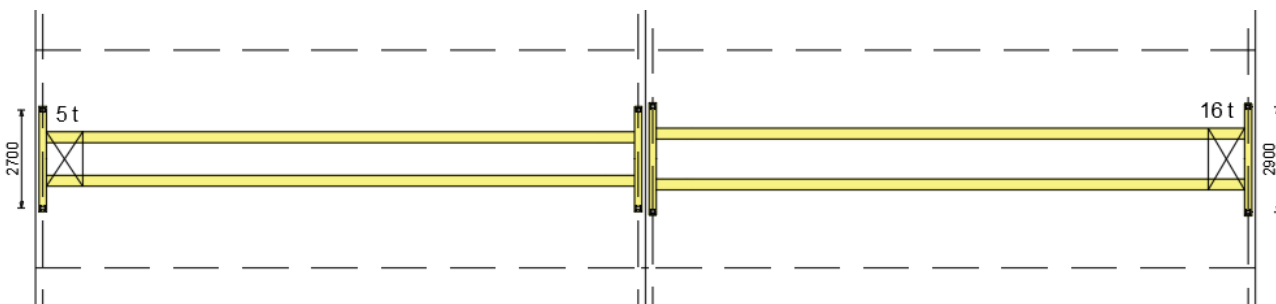

Slika 24. Položaj 7 [izradio autor]

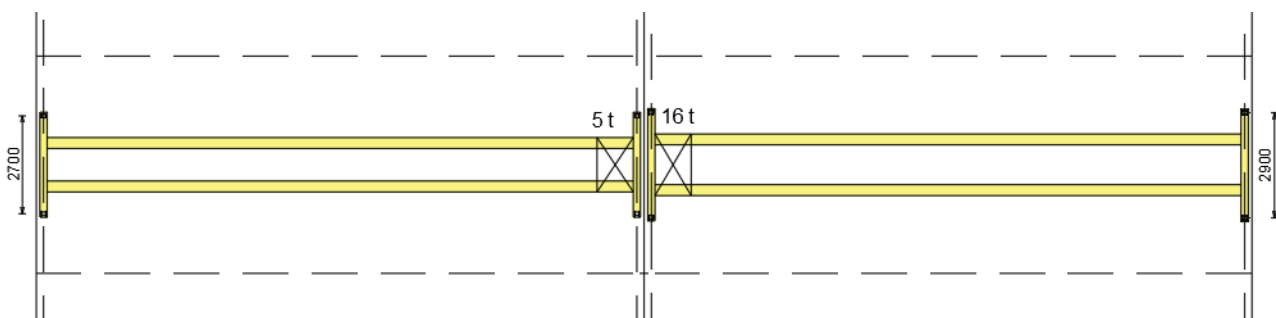

Slika 25. Položaj 8 [izradio autor]

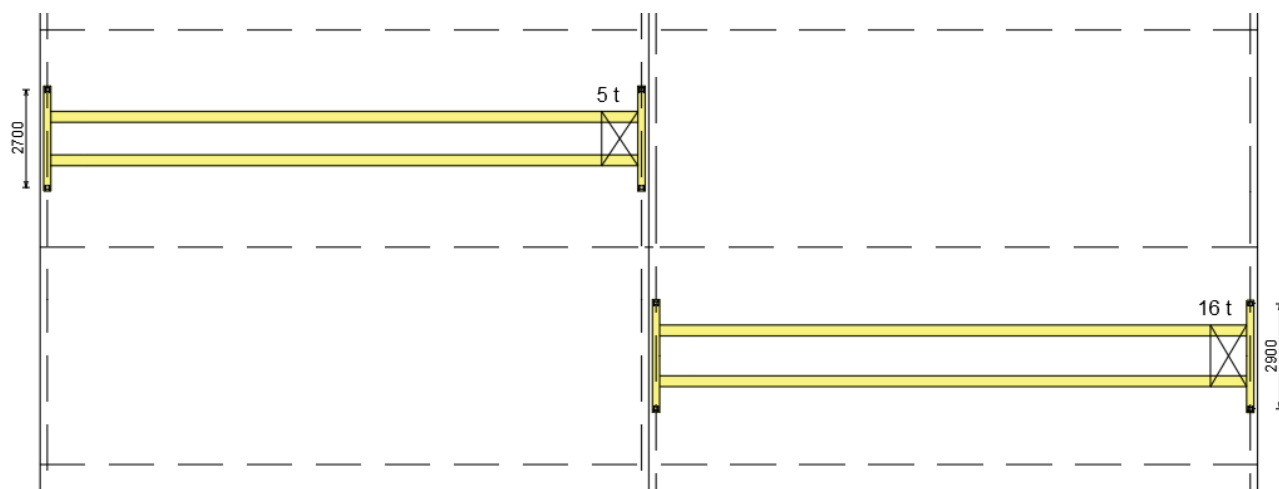

Slika 26. Položaj 9 [izradio autor]

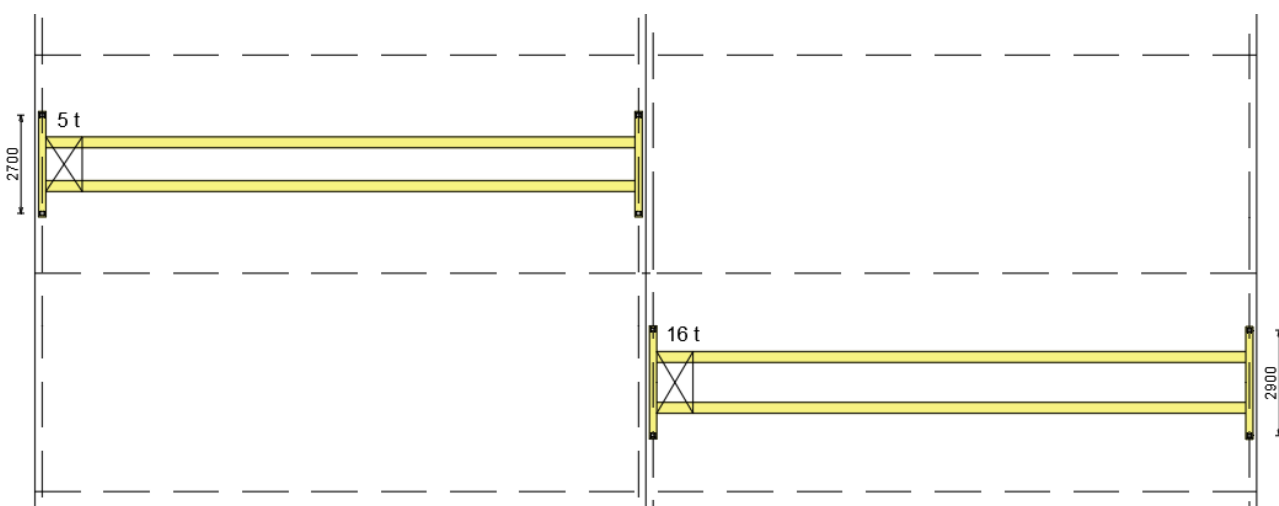

Slika 27. Položaj 10 [izradio autor]

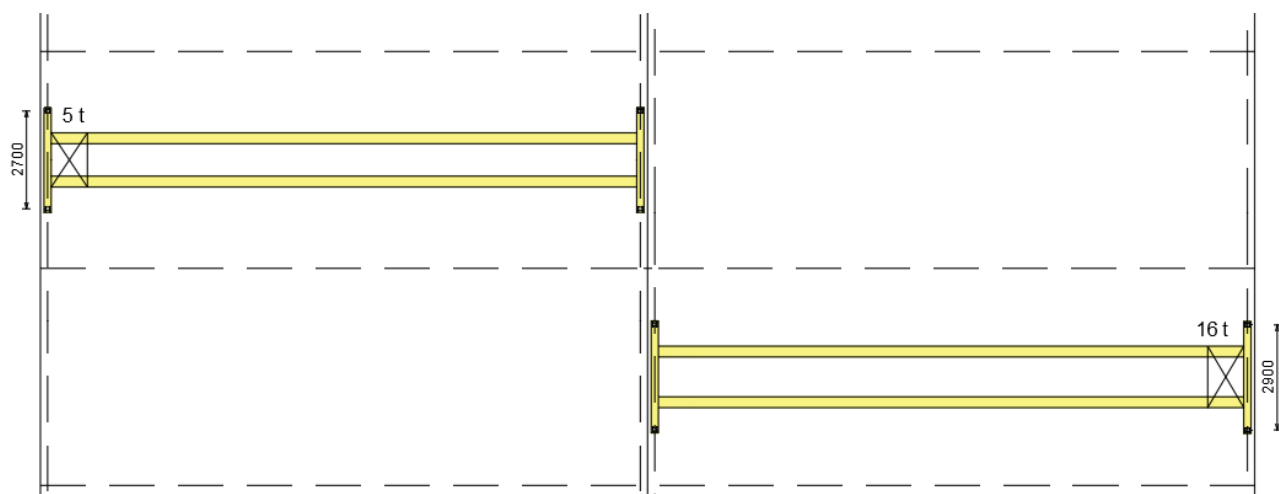

Slika 28. Položaj 11 [izradio autor]

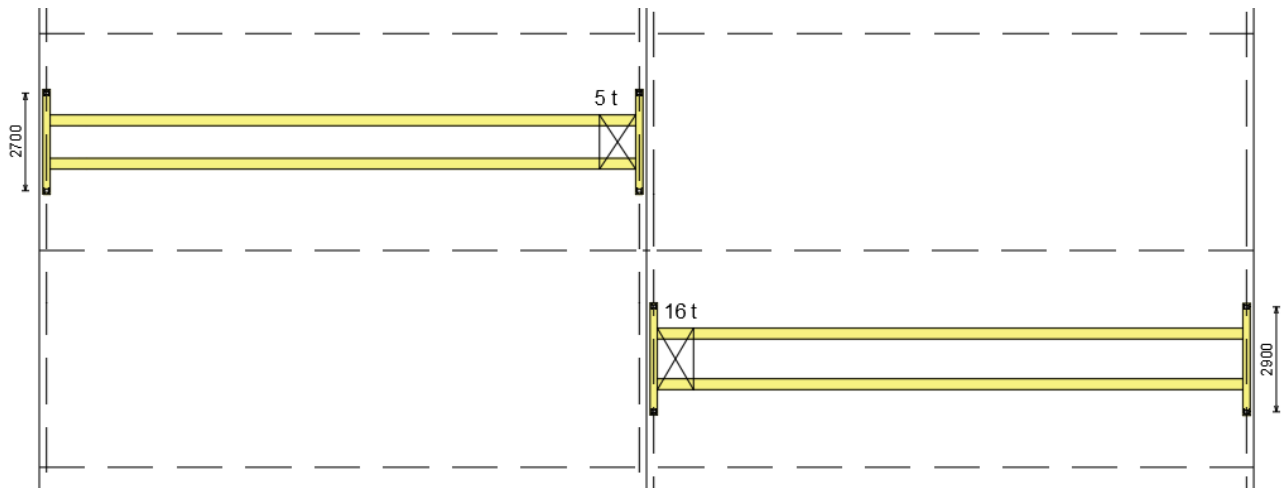

Slika 29. Položaj 12 [izradio autor]

4. Mehanička otpornost i stabilnost konstrukcije

Mehanička otpornost i stabilnost konstrukcije provodi se u programskom paketu Autodesk Robot Structural Analysis. Proračunski model konstrukcije je 3D štapni model.

Oslonci stupova su nepomični s onemogućenim pomacima, a omogućenom rotacijom.

Na Slici 30, prikazan je model konstrukcije proizvodnog pogona.

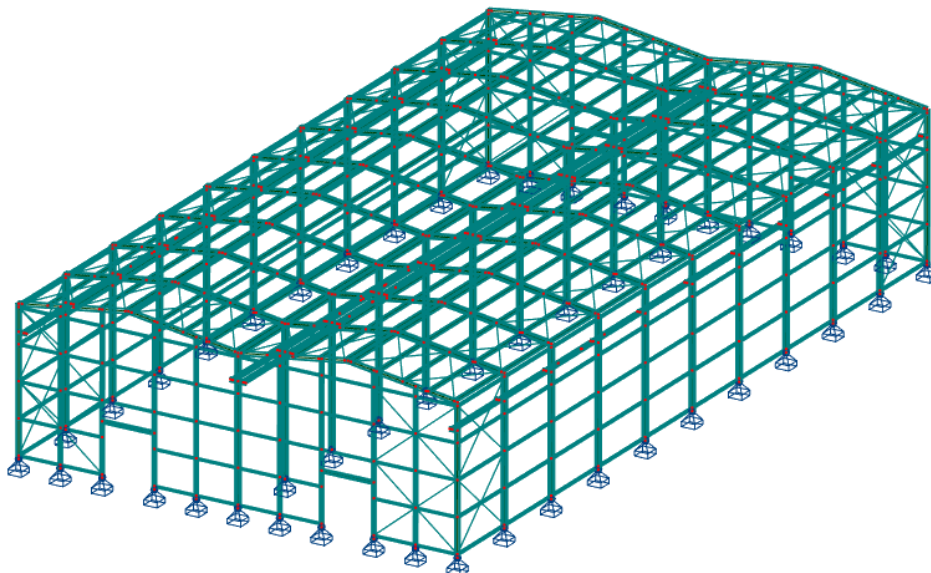

Slika 30. Model konstrukcije [izradio autor]

4.1. Opterećenja na konstrukciju

- Stalno

Vlastitu težinu program *Robot Structural Analysis Professional* sam izračuna

Na Slici 31. prikazano je opterećenje vlastitom težinom na modelu.

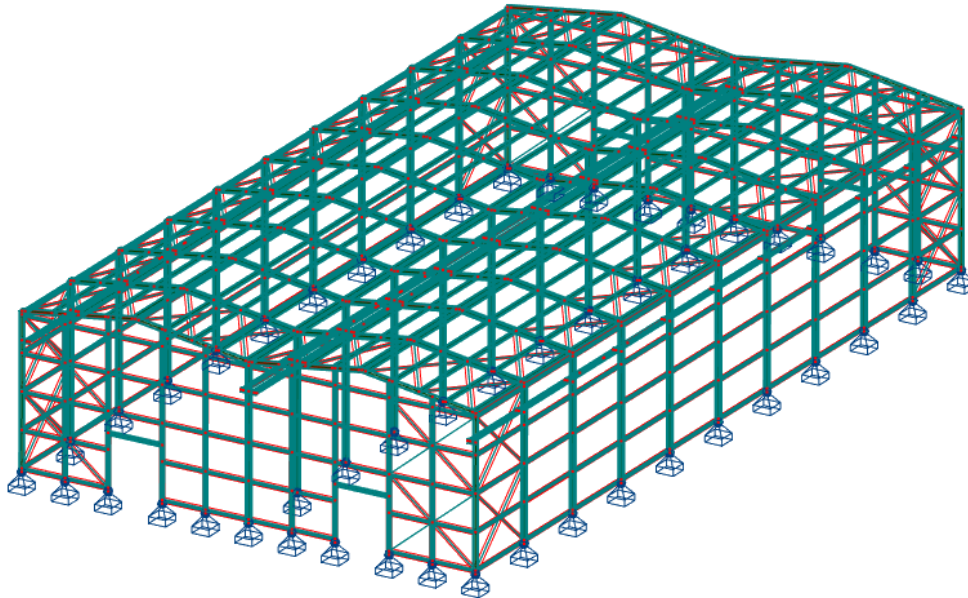

Slika 31. Opterećenje vlastitom težinom [izradio autor]

Opterećenje na podrožnice:

sendvič paneli debljine 10 cm

Trimoterm perform C 100

$$g_p = 0,223 \text{ kN/m}^2$$

Vlastita težina strojarske opreme i instalacija

$$g_p = 0,5 \text{ kN/m}^2$$

Ukupno

$$g_{uk} = 0,723 \text{ kN/m}^2$$

Razmak podrožnica $e = 2 \text{ m}$

Opterećenje na srednje podrožnice

$$G = g \cdot e = 0,723 \cdot 2 = 1,446 \text{ kN/m'}$$

Opterećenje na krajnje podrožnice

$$G = g \cdot \frac{1}{2} \cdot e = 0,723 \text{ kN/m'}$$

Opterećenje na nosače obloge:

Fasadni paneli debljine 10

$$g_f = 0,209 \text{ kN/m}^2$$

Instalacije

$$g_p = 0,5 \text{ kN/m}^2$$

Ukupno

$$g_{uk} = 0,709 \text{ kN/m}^2$$

Razmak obloga $e = 2,625 \text{ m}$ Opterećenje na obloge $G = 0,709 * 2,625 = 1,86 \text{ kN/m'}$ Opterećenje na gornju zabatnu oblogu $G = 1,27 \text{ kN/m'}$ $G = 1,60 \text{ kN/m'}$ $G = 1,96 \text{ kN/m'}$ Opterećenje na gornju i donju oblogu $G = 0,93 \text{ kN/m'}$

Na slici 32. prikazano je stalno opterećenje na modelu.

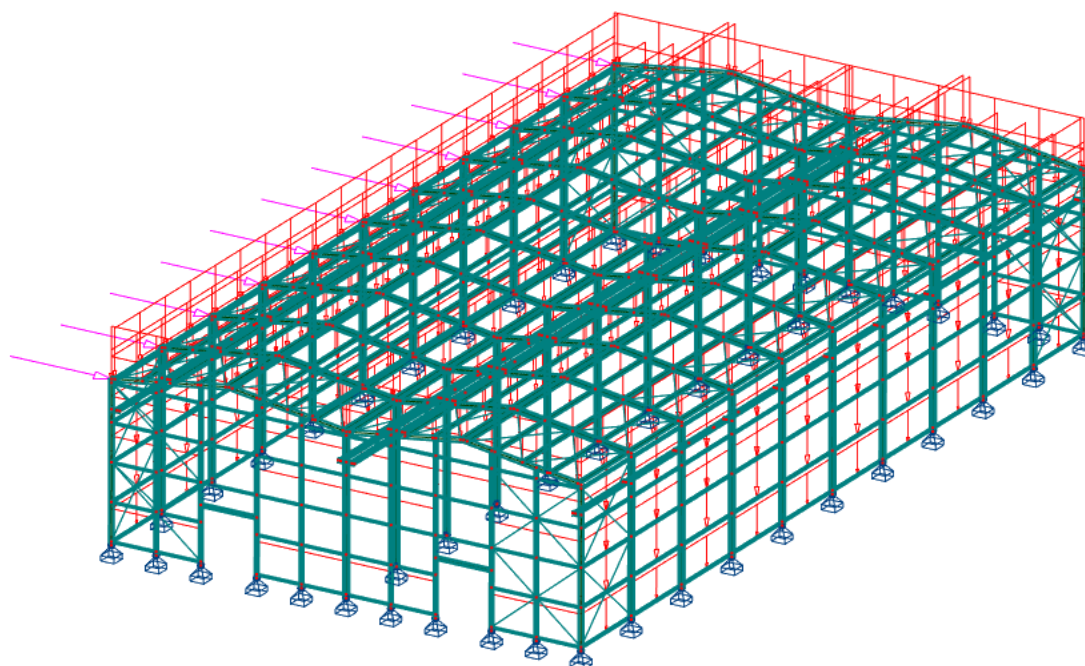

Slika 32. Stalno opterećenje [izradio autor]

- Snijeg

Nesimetrično opterećenje

Opterećenje snijega

$$g_p = 0,4 \text{ kN/m}^2$$

$$g_p = 0,2 \text{ kN/m}^2$$

Razmak podrožnica $e = 2 \text{ m}$

Opterećenje na srednje podrožnice

$$G = g \cdot e = 0,4 \cdot 2 = 0,8 \text{ kN/m'}$$

$$G = g \cdot e = 0,2 \cdot 2 = 0,4 \text{ kN/m'}$$

Opterećenje na krajnje podrožnice i u sljemenu

$$G = g \cdot \frac{1}{2} \cdot e = 0,4 \text{ kN/m'}$$

$$G = g \cdot \frac{1}{2} \cdot e = 0,2 \text{ kN/m'}$$

Na Slici 33., na modelu je prikazano nesimetrično opterećenje snijegom.

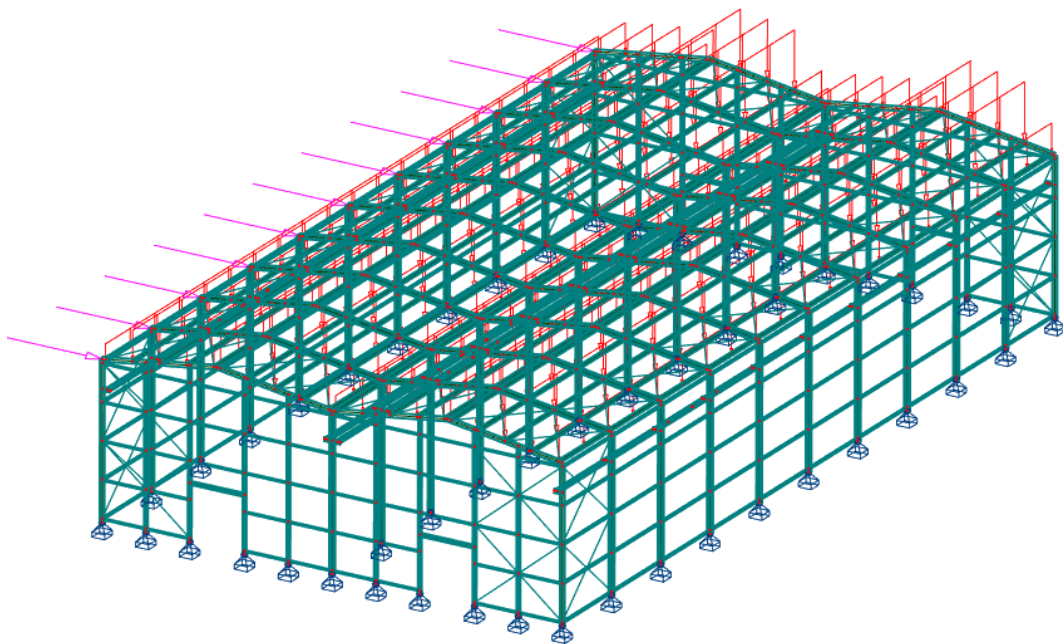

Slika 33. Nesimetrično opterećenje snijegom [izradio autor]

Simetrično opterećenje

Opterećenje snijega

$$g_p = 0,4 \text{ kN/m}^2$$

$$g_p = 0,505 \text{ kN/m}^2$$

Razmak podrožnica $e = 2 \text{ m}$

Opterećenje na srednje podrožnice

$$G = g \cdot e = 0,4 \cdot 2 = 0,8 \text{ kN/m'}$$

$$G = g \cdot e = 0,505 \cdot 2 = 1,10 \text{ kN/m'}$$

Opterećenje na krajnje podrožnice i u sljemenu

$$G = g \cdot \frac{1}{2} \cdot e = 0,4 \text{ kN/m'}$$

$$G = g \cdot \frac{1}{2} \cdot e = 0,505 \text{ kN/m'}$$

Na Slici 34., na modelu je prikazano simetrično opterećenje snijegom.

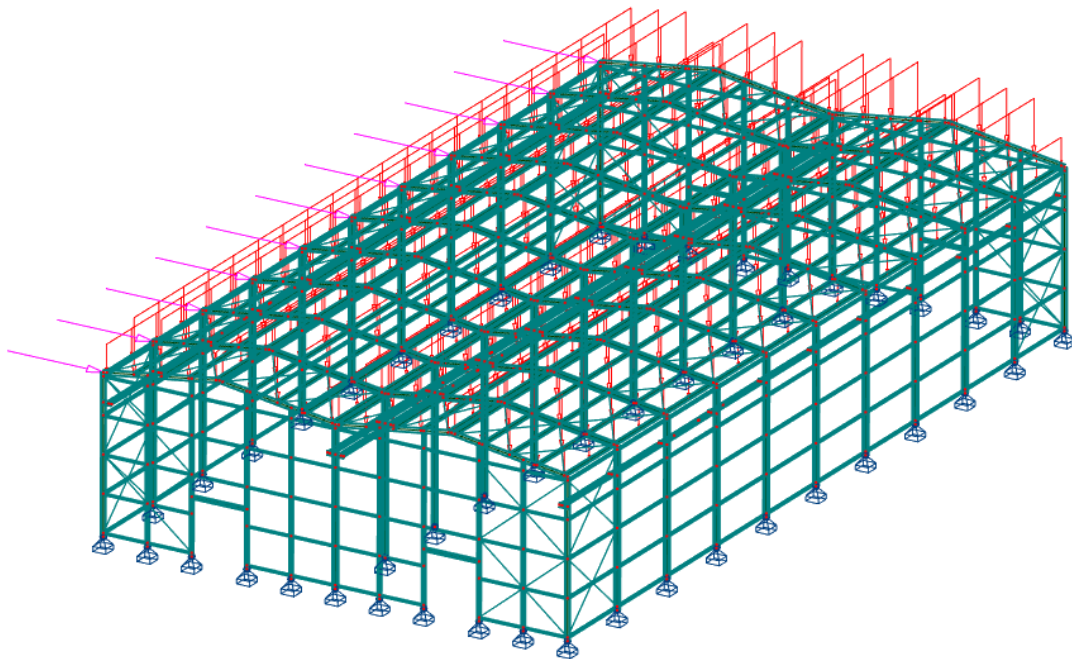

Slika 34. Simetrično opterećenje snijegom [izradio autor]

- Vjetar

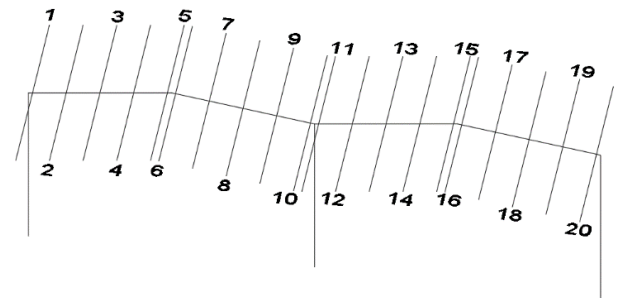
Slučaj 1.Opterećenje na podrožnice:Razmak podrožnica $e = 2 \text{ m}$ 

$$1 \quad \text{spoj D i F zone: } G = g \cdot \frac{1}{2} \cdot e = 1,42 \cdot \frac{1}{2} \cdot 2 = 1,42 \text{ kN/m'}$$

- raspored podrožnica

$$\text{spoj D i G zone: } G = g \cdot \frac{1}{2} \cdot e = 1,05 \cdot \frac{1}{2} \cdot 2 = 1,05 \text{ kN/m'}$$

$$2 \quad G = 1,42 \cdot 1 + 1,42 \cdot 0,2 + 0,50 \cdot 0,8 = 2,1 \text{ kN/m'}$$

$$3, 4 \quad G = 0,50 \cdot 2 = 1,0 \text{ kN/m'}$$

$$5 \quad G = 0,50 \cdot \frac{1}{2} \cdot 2 = 0,50 \text{ kN/m'}$$

$$6, 11 \quad G = 0,61 \cdot \frac{1}{2} \cdot 2 = 0,61 \text{ kN/m'}$$

$$7, 12 \quad G = 0,61 \cdot 1 + 0,61 \cdot 0,2 + 0,56 \cdot 0,8 = 2,28 \text{ kN/m'}$$

$$8, 9, 13, 14 \quad G = 0,56 \cdot 2 = 1,12 \text{ kN/m'}$$

$$10, 15 \quad G = 0,56 \cdot \frac{1}{2} \cdot 2 = 0,56 \text{ kN/m'}$$

$$16, 20 \quad G = 0,34 \cdot \frac{1}{2} \cdot 2 = 0,34 \text{ kN/m'}$$

$$17, 18, 19 \quad G = 0,34 \cdot 2 = 0,68 \text{ kN/m'}$$

Opterećenje na vertikalne stijene:**D zona**

$$\text{-Donji i gornji držači obloge: } G = 0,697 \cdot \frac{1}{2} \cdot 2,625 = 0,915 \text{ kN/m'}$$

$$\text{-Srednji držači obloge: } G = 0,697 \cdot 2,625 = 1,83 \text{ kN/m'}$$

E zona

$$\text{-Donji i gornji držači obloge: } G = 0,314 \cdot \frac{1}{2} \cdot 2,625 = 0,41 \text{ kN/m'}$$

$$\text{-Srednji držači obloge: } G = 0,314 \cdot 2,625 = 0,82 \text{ kN/m'}$$

A zona

$$\text{-Donji i gornji držači obloge: } G = 1,17 \cdot \frac{1}{2} \cdot 2,625 = 1,54 \text{ kN/m'}$$

$$\text{-Srednji držači obloge: } G = 1,17 \cdot 2,625 = 3,07 \text{ kN/m'}$$

B zona

-Donji i gornji držači obloge : $G = 0,78 \cdot \frac{1}{2} \cdot 2,625 = 1,03 \text{ kN/m'}$

-Srednji držači obloge : $G = 0,78 \cdot 2,625 = 2,05 \text{ kN/m'}$

C zona

-Donji i gornji držači obloge : $G = 0,49 \cdot \frac{1}{2} \cdot 2,625 = 0,64 \text{ kN/m'}$

-Srednji držači obloge : $G = 0,49 \cdot 2,625 = 1,28 \text{ kN/m'}$

Na Slici 35., na modelu je prikazano opterećenje vjetrom za slučaj 1.

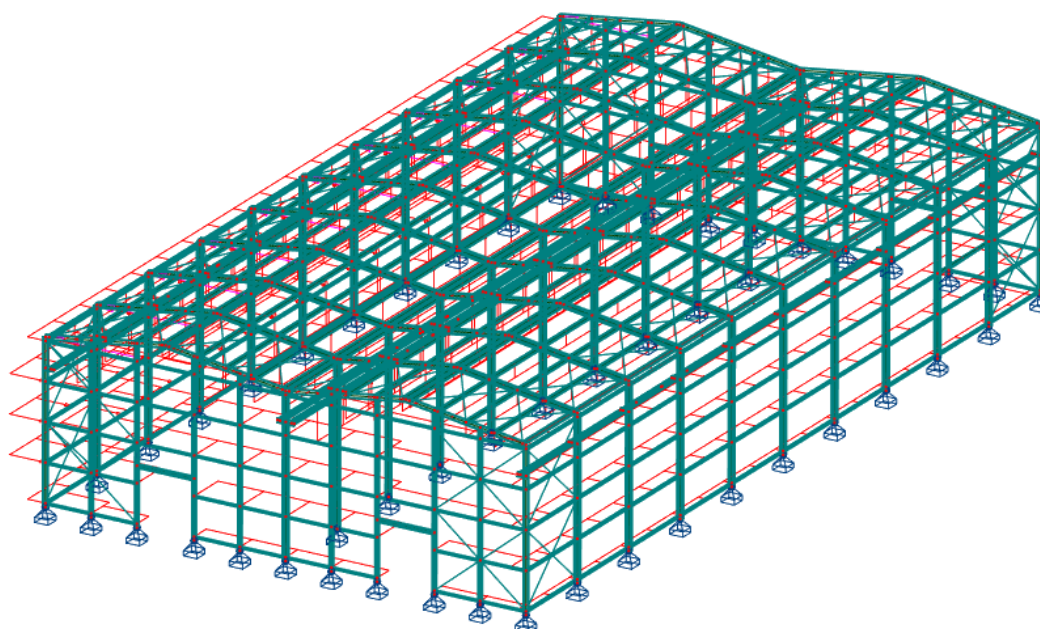

Slika 35. Opterećenje vjetrom (slučaj 1) [izradio autor]

Slučaj 2.Opterećenje na podrožnice:Razmak podrožnica $e = 2 \text{ m}$

- 1 spoj D i F zone: $G = g \cdot \frac{1}{2} \cdot e = 1,18 \cdot \frac{1}{2} \cdot 2 = 1,18 \text{ kN/m'}$
 spoj D i G zone: $G = g \cdot \frac{1}{2} \cdot e = 0,81 \cdot \frac{1}{2} \cdot 2 = 0,81 \text{ kN/m'}$
- 2 $G = 1,18 \cdot 1 + 1,18 \cdot 0,2 + 0,25 \cdot 0,8 = 1,62 \text{ kN/m'}$
- 3, 4 $G = 0,25 \cdot 2 = 0,50 \text{ kN/m'}$
- 5 $G = 0,25 \cdot \frac{1}{2} \cdot 2 = 0,25 \text{ kN/m'}$
- 6, 11 $G = 0,37 \cdot \frac{1}{2} \cdot 2 = 0,37 \text{ kN/m'}$
- 7, 12 $G = 0,37 \cdot 1 + 0,37 \cdot 0,2 + 0,31 \cdot 0,8 = 0,69 \text{ kN/m'}$
- 8, 9, 13, 14 $G = 0,31 \cdot 2 = 0,62 \text{ kN/m'}$
- 10, 15 $G = 0,31 \cdot \frac{1}{2} \cdot 2 = 0,31 \text{ kN/m'}$
- 16, 20 $G = 0,19 \cdot \frac{1}{2} \cdot 2 = 0,19 \text{ kN/m'}$
- 17, 18, 19 $G = 0,19 \cdot 2 = 0,38 \text{ kN/m'}$

Opterećenje na vertikalne stijene:**D zona**

-Donji i gornji držači obloge : $G = 0,985 \cdot \frac{1}{2} \cdot 2,625 = 1,29 \text{ kN/m'}$

-Srednji držači obloge : $G = 0,985 \cdot 2,625 = 2,59 \text{ kN/m'}$

E zona

-Donji i gornji držači obloge : $G = 0,080 \cdot \frac{1}{2} \cdot 2,625 = 0,11 \text{ kN/m'}$

-Srednji držači obloge : $G = 0,080 \cdot 2,625 = 0,21 \text{ kN/m'}$

A zona

-Donji i gornji držači obloge : $G = 0,925 \cdot \frac{1}{2} \cdot 2,625 = 1,21 \text{ kN/m'}$

-Srednji držači obloge : $G = 0,925 \cdot 2,625 = 2,43 \text{ kN/m'}$

B zona

-Donji i gornji držači obloge : $G = 0,54 \cdot \frac{1}{2} \cdot 2,625 = 0,71 \text{ kN/m'}$

-Srednji držači obloge : $G = 0,54 \cdot 2,625 = 1,42 \text{ kN/m'}$

C zona

-Donji i gornji držači obloge : $G = 0,24 \cdot \frac{1}{2} \cdot 2,625 = 0,32 \text{ kN/m'}$

-Srednji držači obloge : $G = 0,24 \cdot 2,625 = 0,63 \text{ kN/m'}$

Na Slici 36., na modelu je prikazano opterećenje vjetrom za slučaj 2.

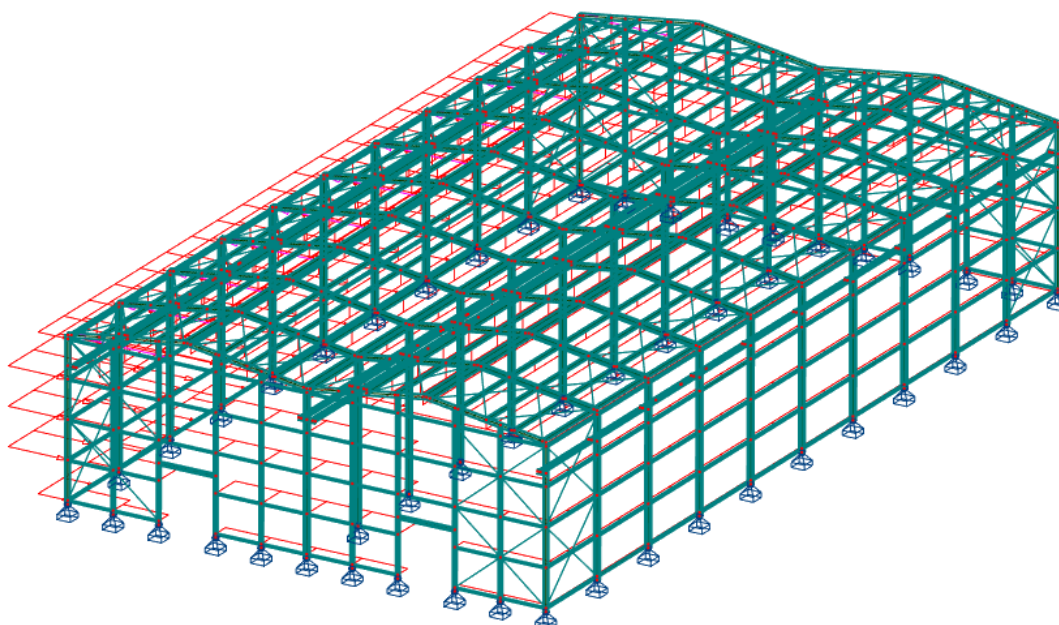

Slika 36. Opterećenje vjetrom (slučaj 2) [izradio autor]

Slučaj 3.Opterećenje na podrožnice:Razmak podrožnica $e = 2 \text{ m}$

- 1.raspon

$$1, 20 \quad G = g \cdot \frac{1}{2} \cdot e = (2,13 \cdot \frac{1}{2} \cdot 2) \cdot 0,41 + (0,64 \cdot \frac{1}{2} \cdot 2) \cdot 0,69 = 1,31 \text{ kN/m'}$$

$$2, 13, 19, 18 \quad G = g \cdot e = (2,13 \cdot 2) \cdot 0,41 + (0,64 \cdot 2) \cdot 0,69 = 2,63 \text{ kN/m'}$$

$$4, 17 \quad G = g \cdot e = (2,13 + 1,78) \cdot 0,41 + (0,64 \cdot 2) \cdot 0,69 = 2,49 \text{ kN/m'}$$

$$5, 6, 10, 11, 15, 16 \quad G = g \cdot \frac{1}{2} \cdot e = (1,78 \cdot \frac{1}{2} \cdot 2) \cdot 0,41 + (0,64 \cdot \frac{1}{2} \cdot 2) \cdot 0,69 = 1,17 \text{ kN/m'}$$

$$7, 8, 9, 12, 13, 14 \quad G = g \cdot e = (1,78 \cdot 2) \cdot 0,41 + (0,64 \cdot 2) \cdot 0,69 = 2,34 \text{ kN/m'}$$

- 2.raspon

$$1, 5, 6, 10, 11, 15, 16, 20 \quad G = g \cdot \frac{1}{2} \cdot e = 0,64 \cdot \frac{1}{2} \cdot 2 = 0,64 \text{ kN/m'}$$

$$2, 3, 4, 7, 8, 9, 12, 13, 14, 17, 18, 19 \quad G = g \cdot e = 0,64 \cdot 2 = 1,28 \text{ kN/m'}$$

- Ostali rasponi

$$1, 5, 6, 10, 11, 15, 16, 20 \quad G = g \cdot \frac{1}{2} \cdot e = 0,55 \cdot \frac{1}{2} \cdot 2 = 0,55 \text{ kN/m'}$$

$$2, 3, 4, 7, 8, 9, 12, 13, 14, 17, 18, 19 \quad G = g \cdot e = 0,55 \cdot 2 = 1,10 \text{ kN/m'}$$

Opterećenje na vertikalne stijene:**D zona**

$$\text{-Donji i gornji držači obloge : } G = 0,68 \cdot \frac{1}{2} \cdot 2,625 = 0,89 \text{ kN/m'}$$

$$\text{-Srednji držači obloge : } G = 0,68 \cdot 2,625 = 1,79 \text{ kN/m'}$$

E zona

$$\text{-Donji i gornji držači obloge : } G = 0,29 \cdot \frac{1}{2} \cdot 2,625 = 0,38 \text{ kN/m'}$$

$$\text{-Srednji držači obloge : } G = 0,29 \cdot 2,625 = 0,76 \text{ kN/m'}$$

A zona

$$\text{-D. i g. držači obloge : } G = g \cdot \frac{1}{2} \cdot e = (1,17 \cdot \frac{1}{2} \cdot 2,625) \cdot 0,81 + (0,78 \cdot \frac{1}{2} \cdot 2,625) \cdot 0,19 = 1,44 \text{ kN/m'}$$

$$\text{-Srednji držači obloge : } G = g \cdot e = (1,17 \cdot 2,625) \cdot 0,81 + (0,78 \cdot 2,625) \cdot 0,19 = 2,88 \text{ kN/m'}$$

B zona

-Donji i gornji držači obloge : $G = 0,78 \cdot \frac{1}{2} \cdot 2,625 = 1,02 \text{ kN/m'}$

-Srednji držači obloge : $G = 0,78 \cdot 2,625 = 2,05 \text{ kN/m'}$

C zona

-Donji i gornji držači obloge : $G = 0,49 \cdot \frac{1}{2} \cdot 2,625 = 0,64 \text{ kN/m'}$

-Srednji držači obloge : $G = 0,49 \cdot 2,625 = 1,29 \text{ kN/m'}$

Na Slici 37., na modelu je prikazano opterećenje vjetrom za slučaj 3.

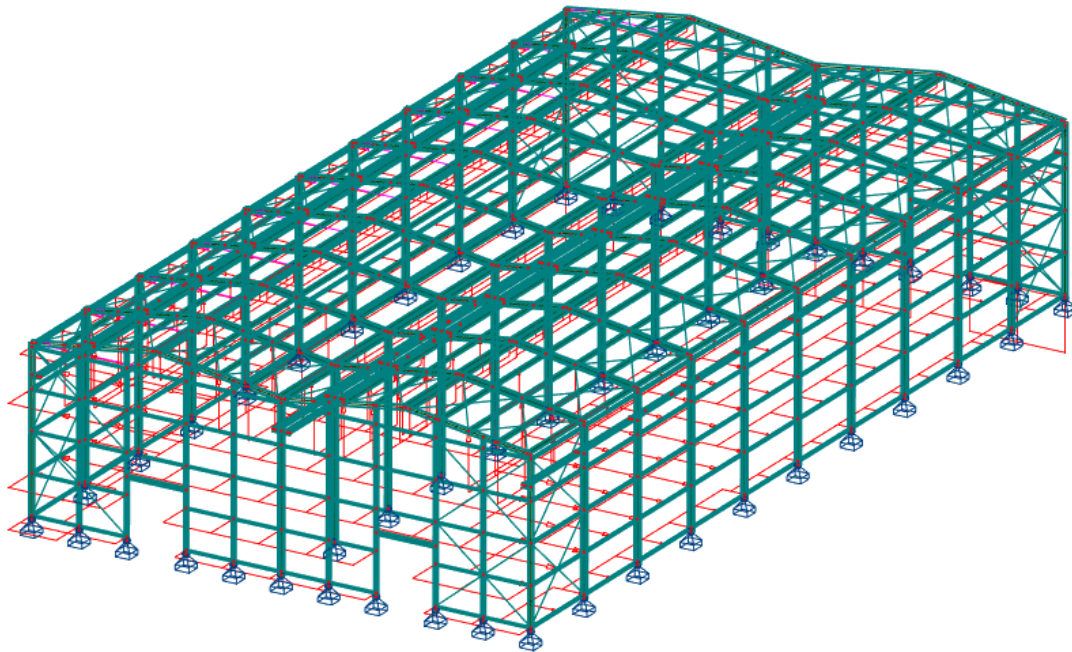

Slika 37. Opterećenje vjetrom (slučaj 3) [izradio autor]

Slučaj 4.Opterećenje na podrožnice:Razmak podrožnica $e = 2$ m

- 1.raspon

$$1, 20 \quad G = g \cdot \frac{1}{2} \cdot e = (1,89 \cdot \frac{1}{2} \cdot 2) \cdot 0,41 + (0,40 \cdot \frac{1}{2} \cdot 2) \cdot 0,69 = 1,05 \text{ kN/m'}$$

$$2, 13, 19, 18 \quad G = g \cdot e = (1,89 \cdot 2) \cdot 0,41 + (0,40 \cdot 2) \cdot 0,69 = 2,10 \text{ kN/m'}$$

$$4, 17 \quad G = g \cdot e = (1,89 + 1,54) \cdot 0,41 + (0,40 \cdot 2) \cdot 0,69 = 1,96 \text{ kN/m'}$$

$$5, 6, 10, 11, 15, 16 \quad G = g \cdot \frac{1}{2} \cdot e = (1,54 \cdot \frac{1}{2} \cdot 2) \cdot 0,41 + (0,40 \cdot \frac{1}{2} \cdot 2) \cdot 0,69 = 0,91 \text{ kN/m'}$$

$$7, 8, 9, 12, 13, 14 \quad G = g \cdot e = (1,54 \cdot 2) \cdot 0,41 + (0,40 \cdot 2) \cdot 0,69 = 1,81 \text{ kN/m'}$$

- 2.raspon

$$1, 5, 6, 10, 11, 15, 16, 20 \quad G = g \cdot \frac{1}{2} \cdot e = 0,40 \cdot \frac{1}{2} \cdot 2 = 0,40 \text{ kN/m'}$$

$$2, 3, 4, 7, 8, 9, 12, 13, 14, 17, 18, 19 \quad G = g \cdot e = 0,40 \cdot 2 = 0,80 \text{ kN/m'}$$

- Ostali rasponi

$$1, 5, 6, 10, 11, 15, 16, 20 \quad G = g \cdot \frac{1}{2} \cdot e = 0,30 \cdot \frac{1}{2} \cdot 2 = 0,30 \text{ kN/m'}$$

$$2, 3, 4, 7, 8, 9, 12, 13, 14, 17, 18, 19 \quad G = g \cdot e = 0,30 \cdot 2 = 0,60 \text{ kN/m'}$$

Opterećenje na vertikalne stijene:**D zona**

$$\text{-Donji i gornji držači obloge : } G = 0,925 \cdot \frac{1}{2} \cdot 2,625 = 1,21 \text{ kN/m'}$$

$$\text{-Srednji držači obloge : } G = 0,925 \cdot 2,625 = 2,43 \text{ kN/m'}$$

E zona

$$\text{-Donji i gornji držači obloge : } G = 0,050 \cdot \frac{1}{2} \cdot 2,625 = 0,066 \text{ kN/m'}$$

$$\text{-Srednji držači obloge : } G = 0,050 \cdot 2,625 = 0,13 \text{ kN/m'}$$

A zona

$$\text{-D. i g. držači obloge : } G = g \cdot \frac{1}{2} \cdot e = (0,93 \cdot \frac{1}{2} \cdot 2,625) \cdot 0,81 + (0,54 \cdot \frac{1}{2} \cdot 2,625) \cdot 0,19 = 1,12 \text{ kN/m'}$$

$$\text{-Srednji držači obloge : } G = g \cdot e = (0,93 \cdot 2,625) \cdot 0,81 + (0,54 \cdot 2,625) \cdot 0,19 = 2,25 \text{ kN/m'}$$

B zona

-Donji i gornji držači obloge : $G = 0,54 \cdot \frac{1}{2} \cdot 2,625 = 0,71 \text{ kN/m'}$

-Srednji držači obloge : $G = 0,54 \cdot 2,625 = 1,42 \text{ kN/m'}$

C zona

-Donji i gornji držači obloge : $G = 0,244 \cdot \frac{1}{2} \cdot 2,625 = 0,32 \text{ kN/m'}$

-Srednji držači obloge : $G = 0,244 \cdot 2,625 = 0,64 \text{ kN/m'}$

Na Slici 38., na modelu je prikazano opterećenje vjetrom za slučaj 4.

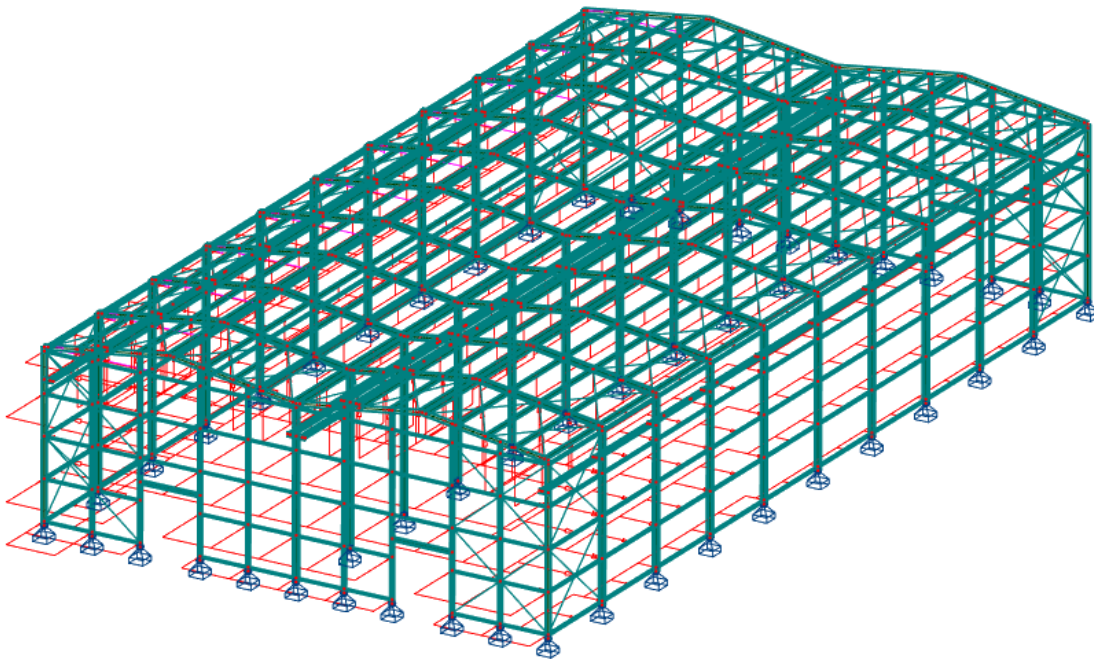

Slika 38. Opterećenje vjetrom (slučaj 4) [izradio autor]

IMPERFEKCIJE OKVIRA

$$\phi = k_c * k_s * \phi_0$$

$$k_c = (0,5 + 1/n_c)^{0,5} = (0,5 + 1/3)^{0,5} = 0,91$$

n_c broj stupova (= 3)

$$k_s = (0,2 + 1/n_s)^{0,5} = (0,2 + 1/1)^{0,5} = 1$$

n_s broj katova (= 1)

$$\phi = 0,91 * 1 * 1/200 = 0,00455$$

$$\Delta H = \phi \cdot V$$

$V_1 = v + g = 377,14$ kN - ukupno vertikalno opterećenje od vlastite težine i stalnog djelovanja

$V_2 = s = 58,18$ kN - ukupno vertikalno opterećenje od snijega 1

$V_3 = s = 82,19$ kN - ukupno vertikalno opterećenje od snijega 2

$V_4 = v1 = -120,17$ kN - ukupno vertikalno opterećenje od vjetra 1

$V_5 = v2 = -64,03$ kN - ukupno vertikalno opterećenje od vjetra 2

$V_6 = v3 = -113,98$ kN - ukupno vertikalno opterećenje od vjetra 3

$V_7 = v4 = -113,92$ kN - ukupno vertikalno opterećenje od vjetra 4

$$\Delta H_1 = 0,00455 \cdot V_1 = 0,00455 * 377,14 = 1,72 \text{ kN}$$

$$\Delta H_2 = 0,00455 \cdot V_2 = 0,00455 * 58,18 = 0,26 \text{ kN}$$

$$\Delta H_3 = 0,00455 \cdot V_3 = 0,00455 * 82,19 = 0,37 \text{ kN}$$

$$\Delta H_4 = 0,00455 \cdot V_4 = 0,00455 * -120,17 = -0,55 \text{ kN}$$

$$\Delta H_5 = 0,00455 \cdot V_5 = 0,00455 * -64,03 = -0,29 \text{ kN}$$

$$\Delta H_6 = 0,00455 \cdot V_6 = 0,00455 * -113,98 = -0,52 \text{ kN}$$

$$\Delta H_7 = 0,00455 \cdot V_7 = 0,00455 * -113,92 = -0,52 \text{ kN}$$

KLASIFIKACIJA OKVIRA

Kriterij poduprt – nepoduprt okvir:

$$\delta_w = (H \cdot h_c) / S_v = (1 \cdot 1100) / 1,5 \cdot 10^8 = 0.0000007 = 0 \text{ cm}$$

$$h_c = 11 \text{ m}$$

$$H = 1 \text{ kN}$$

$$S_v = 2 \cdot n \cdot E \cdot A_d \cdot h_c \cdot L^2 / d^3 = 2 \cdot 4 \cdot 21000 \cdot 40 \cdot 1100 \cdot 3360^2 / 828^3 = 1,5 \cdot 10^8 \text{ kN/cm}$$

$$\delta_{TOT} = 1 / (1 / \delta_F + 1 / \delta_w) = 6,99 \cdot 10^{-7}$$

$$1 - \delta_{TOT} / \delta_F = 1 - 6,99 \cdot 10^{-7} / 0,5 = 99,9 \% \quad \text{okvir je poduprt.}$$

Kriterij pomičan – nepomičan okvir:

Kritična kombinacija za koju je očitana pomak: COMB1

$$\frac{V_d}{V_{cr}} = \frac{\delta}{h} \cdot \frac{V_d}{\sum H_d} = \frac{0,035}{11} \cdot \frac{(107,68+120,20+119,36)}{|(-26,64-4,94-13,06)|} = 0,025 < 0,1 \quad \text{okvir je nepomičan.}$$

- Dozvoljena je analiza 1.reda

5. KOMBINACIJE OPTEREĆENJA

5.1. Za granično stanje nosivosti (GSN ; ULS – Ultimate limit states)

- Proračunska situacija (osnovna) ;

$$\sum_{j \geq 1} \gamma_{k,j} G''_{k,j} + \gamma_p P_k'' + \gamma_{Q,1} Q''_{k,1} + \sum_{i \geq 1} \gamma_{Q,i} \Psi_{0,i} Q''_{k,i}$$

Gdje su:

- G_{kj} – karakteristična vrijednost stalnog djelovanja
- P_k – karakteristična vrijednost djelovanja prednapinjanja
- $Q_{k,1}$ – karakteristična vrijednost vodećeg promjenjivog djelovanja
- $Q_{k,i}$ – karakteristična vrijednost ostalih promjenjivih djelovanja
- $\gamma_{G,j}$ – parcijalni koeficijent sigurnosti stalnih djelovanja j
- γ_p – parcijalni koeficijent sigurnosti za djelovanja prednapinjanja
- $\gamma_{Q,1}$ – parcijalni koeficijent sigurnosti vodećeg promjenjivog djelovanja
- $\gamma_{Q,i}$ – parcijalni koeficijent sigurnosti ostalih promjenjivih djelovanja
- $\Psi_{0,i}$ – koeficijent kombinacije opterećenja

Vrijednosti koeficijenta dane su u Tablici 5.

Tablica 5. Vrijednosti koeficijenta ψ

Djelovanje	Ψ_0	Ψ_1	Ψ_2
Snijeg	0,5	0,2	0
Vjetar	0,6	0,2	0

Djelovanja:

- 1 v – vlastita težina
- 2 g – stalno djelovanje
- 3 s1 – snijeg (nesimetrično)
- 4 s2 – snijeg (simetrično)
- 5 w1 – vjetar (slučaj 1)
- 6 w2 – vjetar (slučaj 2)
- 7 w3 – vjetar (slučaj 3)
- 8 w4 – vjetar (slučaj 4)
- 9 k1 – kranovi (položaj 1)
- 10 k2 – kranovi (položaj 2)
- 11 k3 – kranovi (položaj 3)
- 12 k4 – kranovi (položaj 4)
- 13 k5 – kranovi (položaj 5)
- 14 k6 – kranovi (položaj 6)
- 15 k7 – kranovi (položaj 7)
- 16 k8 – kranovi (položaj 8)
- 17 k9 – kranovi (položaj 9)
- 18 k10 – kranovi (položaj 10)
- 19 k11 – kranovi (položaj 11)
- 20 k12 – kranovi (položaj 12)

Kombijacije:

21 (comb1)	$1,35 \cdot (v + g) + 1,50 \cdot (s1)$
22 (comb2)	$1,35 \cdot (v + g) + 1,50 \cdot (s2)$
23 (comb3)	$1,00 \cdot (v + g) + 1,50 \cdot (w1)$
24 (comb4)	$1,00 \cdot (v + g) + 1,50 \cdot (w2)$
25 (comb5)	$1,00 \cdot (v + g) + 1,50 \cdot (w3)$
26 (comb6)	$1,00 \cdot (v + g) + 1,50 \cdot (w4)$
27 (comb7)	$1,35 \cdot (v + g) + 1,50 \cdot (s1) + 0,6 \cdot 1,50 \cdot (w1)$
28 (comb8)	$1,35 \cdot (v + g) + 1,50 \cdot (s2) + 0,6 \cdot 1,50 \cdot (w1)$
28 (comb9)	$1,35 \cdot (v + g) + 1,50 \cdot (s1) + 0,6 \cdot 1,50 \cdot (w2)$
30 (comb10)	$1,35 \cdot (v + g) + 1,50 \cdot (s2) + 0,6 \cdot 1,50 \cdot (w2)$
31 (comb11)	$1,35 \cdot (v + g) + 1,50 \cdot (s1) + 0,6 \cdot 1,50 \cdot (w3)$
32 (comb12)	$1,35 \cdot (v + g) + 1,50 \cdot (s2) + 0,6 \cdot 1,50 \cdot (w3)$
33 (comb13)	$1,35 \cdot (v + g) + 1,50 \cdot (s1) + 0,6 \cdot 1,50 \cdot (w4)$
34 (comb14)	$1,35 \cdot (v + g) + 1,50 \cdot (s2) + 0,6 \cdot 1,50 \cdot (w4)$
35 (comb15)	$1,35 \cdot (v + g) + 0,50 \cdot 1,50 \cdot (s1) + 1,50 \cdot (w1)$
36 (comb16)	$1,35 \cdot (v + g) + 0,50 \cdot 1,50 \cdot (s2) + 1,50 \cdot (w1)$
37 (comb17)	$1,35 \cdot (v + g) + 0,50 \cdot 1,50 \cdot (s1) + 1,50 \cdot (w2)$
38 (comb18)	$1,35 \cdot (v + g) + 0,50 \cdot 1,50 \cdot (s2) + 1,50 \cdot (w2)$
39 (comb19)	$1,35 \cdot (v + g) + 0,50 \cdot 1,50 \cdot (s1) + 1,50 \cdot (w3)$
40 (comb20)	$1,35 \cdot (v + g) + 0,50 \cdot 1,50 \cdot (s2) + 1,50 \cdot (w3)$
41 (comb21)	$1,35 \cdot (v + g) + 0,50 \cdot 1,50 \cdot (s1) + 1,50 \cdot (w4)$
42 (comb22)	$1,35 \cdot (v + g) + 0,50 \cdot 1,50 \cdot (s2) + 1,50 \cdot (w4)$
43 (comb23)	$1,35 \cdot (v + g) + 1,50 \cdot (s1) + 1,50 \cdot (k1)$
44 (comb24)	$1,35 \cdot (v + g) + 1,50 \cdot (s1) + 1,50 \cdot (k2)$
45 (comb25)	$1,35 \cdot (v + g) + 1,50 \cdot (s1) + 1,50 \cdot (k3)$
46 (comb26)	$1,35 \cdot (v + g) + 1,50 \cdot (s1) + 1,50 \cdot (k4)$
47 (comb27)	$1,35 \cdot (v + g) + 1,50 \cdot (s1) + 1,50 \cdot (k5)$
48 (comb28)	$1,35 \cdot (v + g) + 1,50 \cdot (s1) + 1,50 \cdot (k6)$
49 (comb29)	$1,35 \cdot (v + g) + 1,50 \cdot (s1) + 1,50 \cdot (k7)$
50 (comb30)	$1,35 \cdot (v + g) + 1,50 \cdot (s1) + 1,50 \cdot (k8)$
51 (comb31)	$1,35 \cdot (v + g) + 1,50 \cdot (s1) + 1,50 \cdot (k9)$

52 (comb32)	$1,35 \cdot (v + g) + 1,50 \cdot (s1) + 1,50 \cdot (k10)$
53 (comb33)	$1,35 \cdot (v + g) + 1,50 \cdot (s1) + 1,50 \cdot (k11)$
54 (comb34)	$1,35 \cdot (v + g) + 1,50 \cdot (s1) + 1,50 \cdot (k12)$
55 (comb35)	$1,35 \cdot (v + g) + 1,50 \cdot (s2) + 1,50 \cdot (k1)$
56 (comb36)	$1,35 \cdot (v + g) + 1,50 \cdot (s2) + 1,50 \cdot (k2)$
57 (comb37)	$1,35 \cdot (v + g) + 1,50 \cdot (s2) + 1,50 \cdot (k3)$
58 (comb38)	$1,35 \cdot (v + g) + 1,50 \cdot (s2) + 1,50 \cdot (k4)$
59 (comb39)	$1,35 \cdot (v + g) + 1,50 \cdot (s2) + 1,50 \cdot (k5)$
60 (comb40)	$1,35 \cdot (v + g) + 1,50 \cdot (s2) + 1,50 \cdot (k6)$
61 (comb41)	$1,35 \cdot (v + g) + 1,50 \cdot (s2) + 1,50 \cdot (k7)$
62 (comb42)	$1,35 \cdot (v + g) + 1,50 \cdot (s2) + 1,50 \cdot (k8)$
63 (comb43)	$1,35 \cdot (v + g) + 1,50 \cdot (s2) + 1,50 \cdot (k9)$
64 (comb44)	$1,35 \cdot (v + g) + 1,50 \cdot (s2) + 1,50 \cdot (k10)$
65 (comb45)	$1,35 \cdot (v + g) + 1,50 \cdot (s2) + 1,50 \cdot (k11)$
66 (comb46)	$1,35 \cdot (v + g) + 1,50 \cdot (s2) + 1,50 \cdot (k12)$
67 (comb47)	$1,35 \cdot (v + g) + 1,50 \cdot (s1) + 1,50 \cdot 0,6 \cdot (w1) + 1,50 \cdot (k1)$
68 (comb48)	$1,35 \cdot (v + g) + 1,50 \cdot (s1) + 1,50 \cdot 0,6 \cdot (w1) + 1,50 \cdot (k2)$
69 (comb49)	$1,35 \cdot (v + g) + 1,50 \cdot (s1) + 1,50 \cdot 0,6 \cdot (w1) + 1,50 \cdot (k3)$
70 (comb50)	$1,35 \cdot (v + g) + 1,50 \cdot (s1) + 1,50 \cdot 0,6 \cdot (w1) + 1,50 \cdot (k4)$
71 (comb51)	$1,35 \cdot (v + g) + 1,50 \cdot (s1) + 1,50 \cdot 0,6 \cdot (w1) + 1,50 \cdot (k5)$
72 (comb52)	$1,35 \cdot (v + g) + 1,50 \cdot (s1) + 1,50 \cdot 0,6 \cdot (w1) + 1,50 \cdot (k6)$
73 (comb53)	$1,35 \cdot (v + g) + 1,50 \cdot (s1) + 1,50 \cdot 0,6 \cdot (w1) + 1,50 \cdot (k7)$
74 (comb54)	$1,35 \cdot (v + g) + 1,50 \cdot (s1) + 1,50 \cdot 0,6 \cdot (w1) + 1,50 \cdot (k8)$
75 (comb55)	$1,35 \cdot (v + g) + 1,50 \cdot (s1) + 1,50 \cdot 0,6 \cdot (w1) + 1,50 \cdot (k9)$
76 (comb56)	$1,35 \cdot (v + g) + 1,50 \cdot (s1) + 1,50 \cdot 0,6 \cdot (w1) + 1,50 \cdot (k10)$
77 (comb57)	$1,35 \cdot (v + g) + 1,50 \cdot (s1) + 1,50 \cdot 0,6 \cdot (w1) + 1,50 \cdot (k11)$
78 (comb58)	$1,35 \cdot (v + g) + 1,50 \cdot (s1) + 1,50 \cdot 0,6 \cdot (w1) + 1,50 \cdot (k12)$
79 (comb59)	$1,35 \cdot (v + g) + 1,50 \cdot (s1) + 1,50 \cdot 0,6 \cdot (w2) + 1,50 \cdot (k1)$
80 (comb60)	$1,35 \cdot (v + g) + 1,50 \cdot (s1) + 1,50 \cdot 0,6 \cdot (w2) + 1,50 \cdot (k2)$
81 (comb61)	$1,35 \cdot (v + g) + 1,50 \cdot (s1) + 1,50 \cdot 0,6 \cdot (w2) + 1,50 \cdot (k3)$
82 (comb62)	$1,35 \cdot (v + g) + 1,50 \cdot (s1) + 1,50 \cdot 0,6 \cdot (w2) + 1,50 \cdot (k4)$
83 (comb63)	$1,35 \cdot (v + g) + 1,50 \cdot (s1) + 1,50 \cdot 0,6 \cdot (w2) + 1,50 \cdot (k5)$

84 (comb64)	$1,35 \cdot (v + g) + 1,50 \cdot (s1) + 1,50 \cdot 0,6 \cdot (w2) + 1,50 \cdot (k6)$
85 (comb65)	$1,35 \cdot (v + g) + 1,50 \cdot (s1) + 1,50 \cdot 0,6 \cdot (w2) + 1,50 \cdot (k7)$
86 (comb66)	$1,35 \cdot (v + g) + 1,50 \cdot (s1) + 1,50 \cdot 0,6 \cdot (w2) + 1,50 \cdot (k8)$
87 (comb67)	$1,35 \cdot (v + g) + 1,50 \cdot (s1) + 1,50 \cdot 0,6 \cdot (w2) + 1,50 \cdot (k9)$
88 (comb68)	$1,35 \cdot (v + g) + 1,50 \cdot (s1) + 1,50 \cdot 0,6 \cdot (w2) + 1,50 \cdot (k10)$
89 (comb69)	$1,35 \cdot (v + g) + 1,50 \cdot (s1) + 1,50 \cdot 0,6 \cdot (w2) + 1,50 \cdot (k11)$
90 (comb70)	$1,35 \cdot (v + g) + 1,50 \cdot (s1) + 1,50 \cdot 0,6 \cdot (w2) + 1,50 \cdot (k12)$
91 (comb71)	$1,35 \cdot (v + g) + 1,50 \cdot (s1) + 1,50 \cdot 0,6 \cdot (w3) + 1,50 \cdot (k1)$
92 (comb72)	$1,35 \cdot (v + g) + 1,50 \cdot (s1) + 1,50 \cdot 0,6 \cdot (w3) + 1,50 \cdot (k2)$
93 (comb73)	$1,35 \cdot (v + g) + 1,50 \cdot (s1) + 1,50 \cdot 0,6 \cdot (w3) + 1,50 \cdot (k3)$
94 (comb74)	$1,35 \cdot (v + g) + 1,50 \cdot (s1) + 1,50 \cdot 0,6 \cdot (w3) + 1,50 \cdot (k4)$
95 (comb75)	$1,35 \cdot (v + g) + 1,50 \cdot (s1) + 1,50 \cdot 0,6 \cdot (w3) + 1,50 \cdot (k5)$
96 (comb76)	$1,35 \cdot (v + g) + 1,50 \cdot (s1) + 1,50 \cdot 0,6 \cdot (w3) + 1,50 \cdot (k6)$
97 (comb77)	$1,35 \cdot (v + g) + 1,50 \cdot (s1) + 1,50 \cdot 0,6 \cdot (w3) + 1,50 \cdot (k7)$
98 (comb78)	$1,35 \cdot (v + g) + 1,50 \cdot (s1) + 1,50 \cdot 0,6 \cdot (w3) + 1,50 \cdot (k8)$
99 (comb79)	$1,35 \cdot (v + g) + 1,50 \cdot (s1) + 1,50 \cdot 0,6 \cdot (w3) + 1,50 \cdot (k9)$
100 (comb80)	$1,35 \cdot (v + g) + 1,50 \cdot (s1) + 1,50 \cdot 0,6 \cdot (w3) + 1,50 \cdot (k10)$
101 (comb81)	$1,35 \cdot (v + g) + 1,50 \cdot (s1) + 1,50 \cdot 0,6 \cdot (w3) + 1,50 \cdot (k11)$
102 (comb82)	$1,35 \cdot (v + g) + 1,50 \cdot (s1) + 1,50 \cdot 0,6 \cdot (w3) + 1,50 \cdot (k12)$
103 (comb83)	$1,35 \cdot (v + g) + 1,50 \cdot (s1) + 1,50 \cdot 0,6 \cdot (w4) + 1,50 \cdot (k1)$
104 (comb84)	$1,35 \cdot (v + g) + 1,50 \cdot (s1) + 1,50 \cdot 0,6 \cdot (w4) + 1,50 \cdot (k2)$
105 (comb85)	$1,35 \cdot (v + g) + 1,50 \cdot (s1) + 1,50 \cdot 0,6 \cdot (w4) + 1,50 \cdot (k3)$
106 (comb86)	$1,35 \cdot (v + g) + 1,50 \cdot (s1) + 1,50 \cdot 0,6 \cdot (w4) + 1,50 \cdot (k4)$
107 (comb87)	$1,35 \cdot (v + g) + 1,50 \cdot (s1) + 1,50 \cdot 0,6 \cdot (w4) + 1,50 \cdot (k5)$
108 (comb88)	$1,35 \cdot (v + g) + 1,50 \cdot (s1) + 1,50 \cdot 0,6 \cdot (w4) + 1,50 \cdot (k6)$
109 (comb89)	$1,35 \cdot (v + g) + 1,50 \cdot (s1) + 1,50 \cdot 0,6 \cdot (w4) + 1,50 \cdot (k7)$
110 (comb90)	$1,35 \cdot (v + g) + 1,50 \cdot (s1) + 1,50 \cdot 0,6 \cdot (w4) + 1,50 \cdot (k8)$
111 (comb91)	$1,35 \cdot (v + g) + 1,50 \cdot (s1) + 1,50 \cdot 0,6 \cdot (w4) + 1,50 \cdot (k9)$
112 (comb92)	$1,35 \cdot (v + g) + 1,50 \cdot (s1) + 1,50 \cdot 0,6 \cdot (w4) + 1,50 \cdot (k10)$
113 (comb93)	$1,35 \cdot (v + g) + 1,50 \cdot (s1) + 1,50 \cdot 0,6 \cdot (w4) + 1,50 \cdot (k11)$
114 (comb94)	$1,35 \cdot (v + g) + 1,50 \cdot (s1) + 1,50 \cdot 0,6 \cdot (w4) + 1,50 \cdot (k12)$
115 (comb95)	$1,35 \cdot (v + g) + 1,50 \cdot (s2) + 1,50 \cdot 0,6 \cdot (w1) + 1,50 \cdot (k1)$

116 (comb96)	$1,35 \cdot (v + g) + 1,50 \cdot (s2) + 1,50 \cdot 0,6 \cdot (w1) + 1,50 \cdot (k2)$
117 (comb97)	$1,35 \cdot (v + g) + 1,50 \cdot (s2) + 1,50 \cdot 0,6 \cdot (w1) + 1,50 \cdot (k3)$
118 (comb98)	$1,35 \cdot (v + g) + 1,50 \cdot (s2) + 1,50 \cdot 0,6 \cdot (w1) + 1,50 \cdot (k4)$
119 (comb99)	$1,35 \cdot (v + g) + 1,50 \cdot (s2) + 1,50 \cdot 0,6 \cdot (w1) + 1,50 \cdot (k5)$
120 (comb100)	$1,35 \cdot (v + g) + 1,50 \cdot (s2) + 1,50 \cdot 0,6 \cdot (w1) + 1,50 \cdot (k6)$
121 (comb101)	$1,35 \cdot (v + g) + 1,50 \cdot (s2) + 1,50 \cdot 0,6 \cdot (w1) + 1,50 \cdot (k7)$
122 (comb102)	$1,35 \cdot (v + g) + 1,50 \cdot (s2) + 1,50 \cdot 0,6 \cdot (w1) + 1,50 \cdot (k8)$
123 (comb103)	$1,35 \cdot (v + g) + 1,50 \cdot (s2) + 1,50 \cdot 0,6 \cdot (w1) + 1,50 \cdot (k9)$
124 (comb104)	$1,35 \cdot (v + g) + 1,50 \cdot (s2) + 1,50 \cdot 0,6 \cdot (w1) + 1,50 \cdot (k10)$
125 (comb105)	$1,35 \cdot (v + g) + 1,50 \cdot (s2) + 1,50 \cdot 0,6 \cdot (w1) + 1,50 \cdot (k11)$
126 (comb106)	$1,35 \cdot (v + g) + 1,50 \cdot (s2) + 1,50 \cdot 0,6 \cdot (w1) + 1,50 \cdot (k12)$
127 (comb107)	$1,35 \cdot (v + g) + 1,50 \cdot (s2) + 1,50 \cdot 0,6 \cdot (w2) + 1,50 \cdot (k1)$
128 (comb108)	$1,35 \cdot (v + g) + 1,50 \cdot (s2) + 1,50 \cdot 0,6 \cdot (w2) + 1,50 \cdot (k2)$
129 (comb109)	$1,35 \cdot (v + g) + 1,50 \cdot (s2) + 1,50 \cdot 0,6 \cdot (w2) + 1,50 \cdot (k3)$
130 (comb110)	$1,35 \cdot (v + g) + 1,50 \cdot (s2) + 1,50 \cdot 0,6 \cdot (w2) + 1,50 \cdot (k4)$
131 (comb111)	$1,35 \cdot (v + g) + 1,50 \cdot (s2) + 1,50 \cdot 0,6 \cdot (w2) + 1,50 \cdot (k5)$
132 (comb112)	$1,35 \cdot (v + g) + 1,50 \cdot (s2) + 1,50 \cdot 0,6 \cdot (w2) + 1,50 \cdot (k6)$
133 (comb113)	$1,35 \cdot (v + g) + 1,50 \cdot (s2) + 1,50 \cdot 0,6 \cdot (w2) + 1,50 \cdot (k7)$
134 (comb114)	$1,35 \cdot (v + g) + 1,50 \cdot (s2) + 1,50 \cdot 0,6 \cdot (w2) + 1,50 \cdot (k8)$
135 (comb115)	$1,35 \cdot (v + g) + 1,50 \cdot (s2) + 1,50 \cdot 0,6 \cdot (w2) + 1,50 \cdot (k9)$
136 (comb116)	$1,35 \cdot (v + g) + 1,50 \cdot (s2) + 1,50 \cdot 0,6 \cdot (w2) + 1,50 \cdot (k10)$
137 (comb117)	$1,35 \cdot (v + g) + 1,50 \cdot (s2) + 1,50 \cdot 0,6 \cdot (w2) + 1,50 \cdot (k11)$
138 (comb118)	$1,35 \cdot (v + g) + 1,50 \cdot (s2) + 1,50 \cdot 0,6 \cdot (w2) + 1,50 \cdot (k12)$
139 (comb119)	$1,35 \cdot (v + g) + 1,50 \cdot (s2) + 1,50 \cdot 0,6 \cdot (w3) + 1,50 \cdot (k1)$
140 (comb120)	$1,35 \cdot (v + g) + 1,50 \cdot (s2) + 1,50 \cdot 0,6 \cdot (w3) + 1,50 \cdot (k2)$
141 (comb121)	$1,35 \cdot (v + g) + 1,50 \cdot (s2) + 1,50 \cdot 0,6 \cdot (w3) + 1,50 \cdot (k3)$
142 (comb122)	$1,35 \cdot (v + g) + 1,50 \cdot (s2) + 1,50 \cdot 0,6 \cdot (w3) + 1,50 \cdot (k4)$
143 (comb123)	$1,35 \cdot (v + g) + 1,50 \cdot (s2) + 1,50 \cdot 0,6 \cdot (w3) + 1,50 \cdot (k5)$
144 (comb124)	$1,35 \cdot (v + g) + 1,50 \cdot (s2) + 1,50 \cdot 0,6 \cdot (w3) + 1,50 \cdot (k6)$
145 (comb125)	$1,35 \cdot (v + g) + 1,50 \cdot (s2) + 1,50 \cdot 0,6 \cdot (w3) + 1,50 \cdot (k7)$
146 (comb126)	$1,35 \cdot (v + g) + 1,50 \cdot (s2) + 1,50 \cdot 0,6 \cdot (w3) + 1,50 \cdot (k8)$
147 (comb127)	$1,35 \cdot (v + g) + 1,50 \cdot (s2) + 1,50 \cdot 0,6 \cdot (w3) + 1,50 \cdot (k9)$

148 (comb128)	$1,35 \cdot (v + g) + 1,50 \cdot (s2) + 1,50 \cdot 0,6 \cdot (w3) + 1,50 \cdot (k10)$
149 (comb129)	$1,35 \cdot (v + g) + 1,50 \cdot (s2) + 1,50 \cdot 0,6 \cdot (w3) + 1,50 \cdot (k11)$
150 (comb130)	$1,35 \cdot (v + g) + 1,50 \cdot (s2) + 1,50 \cdot 0,6 \cdot (w3) + 1,50 \cdot (k12)$
151 (comb131)	$1,35 \cdot (v + g) + 1,50 \cdot (s2) + 1,50 \cdot 0,6 \cdot (w4) + 1,50 \cdot (k1)$
152 (comb132)	$1,35 \cdot (v + g) + 1,50 \cdot (s2) + 1,50 \cdot 0,6 \cdot (w4) + 1,50 \cdot (k2)$
153 (comb133)	$1,35 \cdot (v + g) + 1,50 \cdot (s2) + 1,50 \cdot 0,6 \cdot (w4) + 1,50 \cdot (k3)$
154 (comb134)	$1,35 \cdot (v + g) + 1,50 \cdot (s2) + 1,50 \cdot 0,6 \cdot (w4) + 1,50 \cdot (k4)$
155 (comb135)	$1,35 \cdot (v + g) + 1,50 \cdot (s2) + 1,50 \cdot 0,6 \cdot (w4) + 1,50 \cdot (k5)$
156 (comb136)	$1,35 \cdot (v + g) + 1,50 \cdot (s2) + 1,50 \cdot 0,6 \cdot (w4) + 1,50 \cdot (k6)$
157 (comb137)	$1,35 \cdot (v + g) + 1,50 \cdot (s2) + 1,50 \cdot 0,6 \cdot (w4) + 1,50 \cdot (k7)$
158 (comb138)	$1,35 \cdot (v + g) + 1,50 \cdot (s2) + 1,50 \cdot 0,6 \cdot (w4) + 1,50 \cdot (k8)$
159 (comb139)	$1,35 \cdot (v + g) + 1,50 \cdot (s2) + 1,50 \cdot 0,6 \cdot (w4) + 1,50 \cdot (k9)$
160 (comb140)	$1,35 \cdot (v + g) + 1,50 \cdot (s2) + 1,50 \cdot 0,6 \cdot (w4) + 1,50 \cdot (k10)$
161 (comb141)	$1,35 \cdot (v + g) + 1,50 \cdot (s2) + 1,50 \cdot 0,6 \cdot (w4) + 1,50 \cdot (k11)$
162 (comb142)	$1,35 \cdot (v + g) + 1,50 \cdot (s2) + 1,50 \cdot 0,6 \cdot (w4) + 1,50 \cdot (k12)$
163 (comb143)	$1,35 \cdot (v + g) + 1,50 \cdot (w1) + 1,50 \cdot 0,5 \cdot (s1) + 1,50 \cdot (k1)$
164 (comb144)	$1,35 \cdot (v + g) + 1,50 \cdot (w1) + 1,50 \cdot 0,5 \cdot (s1) + 1,50 \cdot (k2)$
165 (comb145)	$1,35 \cdot (v + g) + 1,50 \cdot (w1) + 1,50 \cdot 0,5 \cdot (s1) + 1,50 \cdot (k3)$
166 (comb146)	$1,35 \cdot (v + g) + 1,50 \cdot (w1) + 1,50 \cdot 0,5 \cdot (s1) + 1,50 \cdot (k4)$
167 (comb147)	$1,35 \cdot (v + g) + 1,50 \cdot (w1) + 1,50 \cdot 0,5 \cdot (s1) + 1,50 \cdot (k5)$
168 (comb148)	$1,35 \cdot (v + g) + 1,50 \cdot (w1) + 1,50 \cdot 0,5 \cdot (s1) + 1,50 \cdot (k6)$
169 (comb149)	$1,35 \cdot (v + g) + 1,50 \cdot (w1) + 1,50 \cdot 0,5 \cdot (s1) + 1,50 \cdot (k7)$
170 (comb150)	$1,35 \cdot (v + g) + 1,50 \cdot (w1) + 1,50 \cdot 0,5 \cdot (s1) + 1,50 \cdot (k8)$
171 (comb151)	$1,35 \cdot (v + g) + 1,50 \cdot (w1) + 1,50 \cdot 0,5 \cdot (s1) + 1,50 \cdot (k9)$
172 (comb152)	$1,35 \cdot (v + g) + 1,50 \cdot (w1) + 1,50 \cdot 0,5 \cdot (s1) + 1,50 \cdot (k10)$
173 (comb153)	$1,35 \cdot (v + g) + 1,50 \cdot (w1) + 1,50 \cdot 0,5 \cdot (s1) + 1,50 \cdot (k11)$
174 (comb154)	$1,35 \cdot (v + g) + 1,50 \cdot (w1) + 1,50 \cdot 0,5 \cdot (s1) + 1,50 \cdot (k12)$
175 (comb155)	$1,35 \cdot (v + g) + 1,50 \cdot (w2) + 1,50 \cdot 0,5 \cdot (s1) + 1,50 \cdot (k1)$
176 (comb156)	$1,35 \cdot (v + g) + 1,50 \cdot (w2) + 1,50 \cdot 0,5 \cdot (s1) + 1,50 \cdot (k2)$
177 (comb157)	$1,35 \cdot (v + g) + 1,50 \cdot (w2) + 1,50 \cdot 0,5 \cdot (s1) + 1,50 \cdot (k3)$
178 (comb158)	$1,35 \cdot (v + g) + 1,50 \cdot (w2) + 1,50 \cdot 0,5 \cdot (s1) + 1,50 \cdot (k4)$
179 (comb159)	$1,35 \cdot (v + g) + 1,50 \cdot (w2) + 1,50 \cdot 0,5 \cdot (s1) + 1,50 \cdot (k5)$

180 (comb160)	$1,35 \cdot (v + g) + 1,50 \cdot (w2) + 1,50 \cdot 0,5 \cdot (s1) + 1,50 \cdot (k6)$
181 (comb161)	$1,35 \cdot (v + g) + 1,50 \cdot (w2) + 1,50 \cdot 0,5 \cdot (s1) + 1,50 \cdot (k7)$
182 (comb162)	$1,35 \cdot (v + g) + 1,50 \cdot (w2) + 1,50 \cdot 0,5 \cdot (s1) + 1,50 \cdot (k8)$
183 (comb163)	$1,35 \cdot (v + g) + 1,50 \cdot (w2) + 1,50 \cdot 0,5 \cdot (s1) + 1,50 \cdot (k9)$
184 (comb164)	$1,35 \cdot (v + g) + 1,50 \cdot (w2) + 1,50 \cdot 0,5 \cdot (s1) + 1,50 \cdot (k10)$
185 (comb165)	$1,35 \cdot (v + g) + 1,50 \cdot (w2) + 1,50 \cdot 0,5 \cdot (s1) + 1,50 \cdot (k11)$
186 (comb166)	$1,35 \cdot (v + g) + 1,50 \cdot (w2) + 1,50 \cdot 0,5 \cdot (s1) + 1,50 \cdot (k12)$
187 (comb167)	$1,35 \cdot (v + g) + 1,50 \cdot (w3) + 1,50 \cdot 0,5 \cdot (s1) + 1,50 \cdot (k1)$
188(comb168)	$1,35 \cdot (v + g) + 1,50 \cdot (w3) + 1,50 \cdot 0,5 \cdot (s1) + 1,50 \cdot (k2)$
189 (comb169)	$1,35 \cdot (v + g) + 1,50 \cdot (w3) + 1,50 \cdot 0,5 \cdot (s1) + 1,50 \cdot (k3)$
190 (comb170)	$1,35 \cdot (v + g) + 1,50 \cdot (w3) + 1,50 \cdot 0,5 \cdot (s1) + 1,50 \cdot (k4)$
191 (comb171)	$1,35 \cdot (v + g) + 1,50 \cdot (w3) + 1,50 \cdot 0,5 \cdot (s1) + 1,50 \cdot (k5)$
192 (comb172)	$1,35 \cdot (v + g) + 1,50 \cdot (w3) + 1,50 \cdot 0,5 \cdot (s1) + 1,50 \cdot (k6)$
193 (comb173)	$1,35 \cdot (v + g) + 1,50 \cdot (w3) + 1,50 \cdot 0,5 \cdot (s1) + 1,50 \cdot (k7)$
194 (comb174)	$1,35 \cdot (v + g) + 1,50 \cdot (w3) + 1,50 \cdot 0,5 \cdot (s1) + 1,50 \cdot (k8)$
195 (comb175)	$1,35 \cdot (v + g) + 1,50 \cdot (w3) + 1,50 \cdot 0,5 \cdot (s1) + 1,50 \cdot (k9)$
196 (comb176)	$1,35 \cdot (v + g) + 1,50 \cdot (w3) + 1,50 \cdot 0,5 \cdot (s1) + 1,50 \cdot (k10)$
197 (comb177)	$1,35 \cdot (v + g) + 1,50 \cdot (w3) + 1,50 \cdot 0,5 \cdot (s1) + 1,50 \cdot (k11)$
198 (comb178)	$1,35 \cdot (v + g) + 1,50 \cdot (w3) + 1,50 \cdot 0,5 \cdot (s1) + 1,50 \cdot (k12)$
199 (comb179)	$1,35 \cdot (v + g) + 1,50 \cdot (w4) + 1,50 \cdot 0,5 \cdot (s1) + 1,50 \cdot (k1)$
200 (comb180)	$1,35 \cdot (v + g) + 1,50 \cdot (w4) + 1,50 \cdot 0,5 \cdot (s1) + 1,50 \cdot (k2)$
201 (comb181)	$1,35 \cdot (v + g) + 1,50 \cdot (w4) + 1,50 \cdot 0,5 \cdot (s1) + 1,50 \cdot (k3)$
202 (comb182)	$1,35 \cdot (v + g) + 1,50 \cdot (w4) + 1,50 \cdot 0,5 \cdot (s1) + 1,50 \cdot (k4)$
203 (comb183)	$1,35 \cdot (v + g) + 1,50 \cdot (w4) + 1,50 \cdot 0,5 \cdot (s1) + 1,50 \cdot (k5)$
204 (comb184)	$1,35 \cdot (v + g) + 1,50 \cdot (w4) + 1,50 \cdot 0,5 \cdot (s1) + 1,50 \cdot (k6)$
205 (comb185)	$1,35 \cdot (v + g) + 1,50 \cdot (w4) + 1,50 \cdot 0,5 \cdot (s1) + 1,50 \cdot (k7)$
206 (comb186)	$1,35 \cdot (v + g) + 1,50 \cdot (w4) + 1,50 \cdot 0,5 \cdot (s1) + 1,50 \cdot (k8)$
207 (comb187)	$1,35 \cdot (v + g) + 1,50 \cdot (w4) + 1,50 \cdot 0,5 \cdot (s1) + 1,50 \cdot (k9)$
208 (comb188)	$1,35 \cdot (v + g) + 1,50 \cdot (w4) + 1,50 \cdot 0,5 \cdot (s1) + 1,50 \cdot (k10)$
209 (comb189)	$1,35 \cdot (v + g) + 1,50 \cdot (w4) + 1,50 \cdot 0,5 \cdot (s1) + 1,50 \cdot (k11)$
210 (comb190)	$1,35 \cdot (v + g) + 1,50 \cdot (w4) + 1,50 \cdot 0,5 \cdot (s1) + 1,50 \cdot (k12)$
211 (comb191)	$1,35 \cdot (v + g) + 1,50 \cdot (w1) + 1,50 \cdot 0,5 \cdot (s2) + 1,50 \cdot (k1)$

212 (comb192)	$1,35 \cdot (v + g) + 1,50 \cdot (w1) + 1,50 \cdot 0,5 \cdot (s2) + 1,50 \cdot (k2)$
213 (comb193)	$1,35 \cdot (v + g) + 1,50 \cdot (w1) + 1,50 \cdot 0,5 \cdot (s2) + 1,50 \cdot (k3)$
214 (comb194)	$1,35 \cdot (v + g) + 1,50 \cdot (w1) + 1,50 \cdot 0,5 \cdot (s2) + 1,50 \cdot (k4)$
215 (comb195)	$1,35 \cdot (v + g) + 1,50 \cdot (w1) + 1,50 \cdot 0,5 \cdot (s2) + 1,50 \cdot (k5)$
216 (comb196)	$1,35 \cdot (v + g) + 1,50 \cdot (w1) + 1,50 \cdot 0,5 \cdot (s2) + 1,50 \cdot (k6)$
217 (comb197)	$1,35 \cdot (v + g) + 1,50 \cdot (w1) + 1,50 \cdot 0,5 \cdot (s2) + 1,50 \cdot (k7)$
218 (comb198)	$1,35 \cdot (v + g) + 1,50 \cdot (w1) + 1,50 \cdot 0,5 \cdot (s2) + 1,50 \cdot (k8)$
219 (comb199)	$1,35 \cdot (v + g) + 1,50 \cdot (w1) + 1,50 \cdot 0,5 \cdot (s2) + 1,50 \cdot (k9)$
220 (comb200)	$1,35 \cdot (v + g) + 1,50 \cdot (w1) + 1,50 \cdot 0,5 \cdot (s2) + 1,50 \cdot (k10)$
221 (comb201)	$1,35 \cdot (v + g) + 1,50 \cdot (w1) + 1,50 \cdot 0,5 \cdot (s2) + 1,50 \cdot (k11)$
222 (comb202)	$1,35 \cdot (v + g) + 1,50 \cdot (w1) + 1,50 \cdot 0,5 \cdot (s2) + 1,50 \cdot (k12)$
223 (comb203)	$1,35 \cdot (v + g) + 1,50 \cdot (w2) + 1,50 \cdot 0,5 \cdot (s2) + 1,50 \cdot (k1)$
224 (comb204)	$1,35 \cdot (v + g) + 1,50 \cdot (w2) + 1,50 \cdot 0,5 \cdot (s2) + 1,50 \cdot (k2)$
225 (comb205)	$1,35 \cdot (v + g) + 1,50 \cdot (w2) + 1,50 \cdot 0,5 \cdot (s2) + 1,50 \cdot (k3)$
226 (comb206)	$1,35 \cdot (v + g) + 1,50 \cdot (w2) + 1,50 \cdot 0,5 \cdot (s2) + 1,50 \cdot (k4)$
227 (comb207)	$1,35 \cdot (v + g) + 1,50 \cdot (w2) + 1,50 \cdot 0,5 \cdot (s2) + 1,50 \cdot (k5)$
228 (comb208)	$1,35 \cdot (v + g) + 1,50 \cdot (w2) + 1,50 \cdot 0,5 \cdot (s2) + 1,50 \cdot (k6)$
229 (comb209)	$1,35 \cdot (v + g) + 1,50 \cdot (w2) + 1,50 \cdot 0,5 \cdot (s2) + 1,50 \cdot (k7)$
230 (comb210)	$1,35 \cdot (v + g) + 1,50 \cdot (w2) + 1,50 \cdot 0,5 \cdot (s2) + 1,50 \cdot (k8)$
231 (comb211)	$1,35 \cdot (v + g) + 1,50 \cdot (w2) + 1,50 \cdot 0,5 \cdot (s2) + 1,50 \cdot (k9)$
232 (comb212)	$1,35 \cdot (v + g) + 1,50 \cdot (w2) + 1,50 \cdot 0,5 \cdot (s2) + 1,50 \cdot (k10)$
233 (comb213)	$1,35 \cdot (v + g) + 1,50 \cdot (w2) + 1,50 \cdot 0,5 \cdot (s2) + 1,50 \cdot (k11)$
234 (comb214)	$1,35 \cdot (v + g) + 1,50 \cdot (w2) + 1,50 \cdot 0,5 \cdot (s2) + 1,50 \cdot (k12)$
235 (comb215)	$1,35 \cdot (v + g) + 1,50 \cdot (w3) + 1,50 \cdot 0,5 \cdot (s2) + 1,50 \cdot (k1)$
236 (comb216)	$1,35 \cdot (v + g) + 1,50 \cdot (w3) + 1,50 \cdot 0,5 \cdot (s2) + 1,50 \cdot (k2)$
237 (comb217)	$1,35 \cdot (v + g) + 1,50 \cdot (w3) + 1,50 \cdot 0,5 \cdot (s2) + 1,50 \cdot (k3)$
238 (comb218)	$1,35 \cdot (v + g) + 1,50 \cdot (w3) + 1,50 \cdot 0,5 \cdot (s2) + 1,50 \cdot (k4)$
239 (comb219)	$1,35 \cdot (v + g) + 1,50 \cdot (w3) + 1,50 \cdot 0,5 \cdot (s2) + 1,50 \cdot (k5)$
240 (comb220)	$1,35 \cdot (v + g) + 1,50 \cdot (w3) + 1,50 \cdot 0,5 \cdot (s2) + 1,50 \cdot (k6)$
241 (comb221)	$1,35 \cdot (v + g) + 1,50 \cdot (w3) + 1,50 \cdot 0,5 \cdot (s2) + 1,50 \cdot (k7)$
242 (comb222)	$1,35 \cdot (v + g) + 1,50 \cdot (w3) + 1,50 \cdot 0,5 \cdot (s2) + 1,50 \cdot (k8)$
243 (comb223)	$1,35 \cdot (v + g) + 1,50 \cdot (w3) + 1,50 \cdot 0,5 \cdot (s2) + 1,50 \cdot (k9)$

244 (comb224)	$1,35 \cdot (v + g) + 1,50 \cdot (w3) + 1,50 \cdot 0,5 \cdot (s2) + 1,50 \cdot (k10)$
245 (comb225)	$1,35 \cdot (v + g) + 1,50 \cdot (w3) + 1,50 \cdot 0,5 \cdot (s2) + 1,50 \cdot (k11)$
246 (comb226)	$1,35 \cdot (v + g) + 1,50 \cdot (w3) + 1,50 \cdot 0,5 \cdot (s2) + 1,50 \cdot (k12)$
247 (comb227)	$1,35 \cdot (v + g) + 1,50 \cdot (w4) + 1,50 \cdot 0,5 \cdot (s2) + 1,50 \cdot (k1)$
248 (comb228)	$1,35 \cdot (v + g) + 1,50 \cdot (w4) + 1,50 \cdot 0,5 \cdot (s2) + 1,50 \cdot (k2)$
249 (comb229)	$1,35 \cdot (v + g) + 1,50 \cdot (w4) + 1,50 \cdot 0,5 \cdot (s2) + 1,50 \cdot (k3)$
250 (comb230)	$1,35 \cdot (v + g) + 1,50 \cdot (w4) + 1,50 \cdot 0,5 \cdot (s2) + 1,50 \cdot (k4)$
251 (comb231)	$1,35 \cdot (v + g) + 1,50 \cdot (w4) + 1,50 \cdot 0,5 \cdot (s2) + 1,50 \cdot (k5)$
252 (comb232)	$1,35 \cdot (v + g) + 1,50 \cdot (w4) + 1,50 \cdot 0,5 \cdot (s2) + 1,50 \cdot (k6)$
253 (comb233)	$1,35 \cdot (v + g) + 1,50 \cdot (w4) + 1,50 \cdot 0,5 \cdot (s2) + 1,50 \cdot (k7)$
254 (comb234)	$1,35 \cdot (v + g) + 1,50 \cdot (w4) + 1,50 \cdot 0,5 \cdot (s2) + 1,50 \cdot (k8)$
255 (comb235)	$1,35 \cdot (v + g) + 1,50 \cdot (w4) + 1,50 \cdot 0,5 \cdot (s2) + 1,50 \cdot (k9)$
256 (comb236)	$1,35 \cdot (v + g) + 1,50 \cdot (w4) + 1,50 \cdot 0,5 \cdot (s2) + 1,50 \cdot (k10)$
257 (comb237)	$1,35 \cdot (v + g) + 1,50 \cdot (w4) + 1,50 \cdot 0,5 \cdot (s2) + 1,50 \cdot (k11)$
258 (comb238)	$1,35 \cdot (v + g) + 1,50 \cdot (w4) + 1,50 \cdot 0,5 \cdot (s2) + 1,50 \cdot (k12)$

5.2. Za granično stanje uporabivosti (GSU; SLS – Serviceability limit states)

- Proračunska situacija (karakteristična);

$$\sum_{j \geq 1} G''_{k,j} + '' Q''_{k,1} + '' \sum_{i \geq 1} \gamma_{Q,1} \Psi_{0,1} Q_{k,i}''$$

Kombinacije:

259 (comb239)	$1,00 \cdot (v + g) + 1,00 \cdot (s1)$
260 (comb240)	$1,00 \cdot (v + g) + 1,00 \cdot (s2)$
261 (comb241)	$1,00 \cdot (v + g) + 1,00 \cdot (w1)$
262 (comb242)	$1,00 \cdot (v + g) + 1,00 \cdot (w2)$
263 (comb243)	$1,00 \cdot (v + g) + 1,00 \cdot (w3)$
264 (comb242)	$1,00 \cdot (v + g) + 1,00 \cdot (w4)$
265 (comb245)	$1,00 \cdot (v + g) + 1,00 \cdot (s1) + 0,6 \cdot 1,00 \cdot (w1)$
266 (comb246)	$1,00 \cdot (v + g) + 1,00 \cdot (s2) + 0,6 \cdot 1,00 \cdot (w1)$

267 (comb247)	$1,00 \cdot (v + g) + 1,00 \cdot (s1) + 0,6 \cdot 1,00 \cdot (w2)$
268 (comb248)	$1,00 \cdot (v + g) + 1,00 \cdot (s2) + 0,6 \cdot 1,00 \cdot (w2)$
269 (comb249)	$1,00 \cdot (v + g) + 1,00 \cdot (s1) + 0,6 \cdot 1,00 \cdot (w3)$
270 (comb250)	$1,00 \cdot (v + g) + 1,00 \cdot (s2) + 0,6 \cdot 1,00 \cdot (w3)$
271 (comb251)	$1,00 \cdot (v + g) + 1,00 \cdot (s1) + 0,6 \cdot 1,00 \cdot (w4)$
272 (comb252)	$1,00 \cdot (v + g) + 1,00 \cdot (s2) + 0,6 \cdot 1,00 \cdot (w4)$
273 (comb253)	$1,00 \cdot (v + g) + 0,50 \cdot 1,00 \cdot (s1) + 1,00 \cdot (w1)$
274 (comb254)	$1,00 \cdot (v + g) + 0,50 \cdot 1,00 \cdot (s2) + 1,00 \cdot (w1)$
275 (comb255)	$1,00 \cdot (v + g) + 0,50 \cdot 1,00 \cdot (s1) + 1,00 \cdot (w2)$
276 (comb256)	$1,00 \cdot (v + g) + 0,50 \cdot 1,00 \cdot (s2) + 1,00 \cdot (w2)$
277 (comb257)	$1,00 \cdot (v + g) + 0,50 \cdot 1,00 \cdot (s1) + 1,00 \cdot (w3)$
278 (comb258)	$1,00 \cdot (v + g) + 0,50 \cdot 1,00 \cdot (s2) + 1,00 \cdot (w3)$
279 (comb259)	$1,00 \cdot (v + g) + 0,50 \cdot 1,00 \cdot (s1) + 1,00 \cdot (w4)$
280 (comb260)	$1,00 \cdot (v + g) + 0,50 \cdot 1,00 \cdot (s2) + 1,00 \cdot (w4)$
281 (comb261)	$1,00 \cdot (v + g) + 1,00 \cdot (s1) + 1,00 \cdot (k1)$
282 (comb262)	$1,00 \cdot (v + g) + 1,00 \cdot (s1) + 1,00 \cdot (k2)$
283 (comb263)	$1,00 \cdot (v + g) + 1,00 \cdot (s1) + 1,00 \cdot (k3)$
284 (comb264)	$1,00 \cdot (v + g) + 1,00 \cdot (s1) + 1,00 \cdot (k4)$
285 (comb265)	$1,00 \cdot (v + g) + 1,00 \cdot (s1) + 1,00 \cdot (k5)$
286 (comb266)	$1,00 \cdot (v + g) + 1,00 \cdot (s1) + 1,00 \cdot (k6)$
287 (comb267)	$1,00 \cdot (v + g) + 1,00 \cdot (s1) + 1,00 \cdot (k7)$
288 (comb268)	$1,00 \cdot (v + g) + 1,00 \cdot (s1) + 1,00 \cdot (k8)$
289 (comb269)	$1,00 \cdot (v + g) + 1,00 \cdot (s1) + 1,00 \cdot (k9)$
290 (comb270)	$1,00 \cdot (v + g) + 1,00 \cdot (s1) + 1,00 \cdot (k10)$
291 (comb271)	$1,00 \cdot (v + g) + 1,00 \cdot (s1) + 1,00 \cdot (k11)$
292 (comb272)	$1,00 \cdot (v + g) + 1,00 \cdot (s1) + 1,00 \cdot (k12)$
293 (comb273)	$1,00 \cdot (v + g) + 1,00 \cdot (s2) + 1,00 \cdot (k1)$
294 (comb274)	$1,00 \cdot (v + g) + 1,00 \cdot (s2) + 1,00 \cdot (k2)$
295 (comb275)	$1,00 \cdot (v + g) + 1,00 \cdot (s2) + 1,00 \cdot (k3)$
296 (comb276)	$1,00 \cdot (v + g) + 1,00 \cdot (s2) + 1,00 \cdot (k4)$
297 (comb277)	$1,00 \cdot (v + g) + 1,00 \cdot (s2) + 1,00 \cdot (k5)$
298 (comb278)	$1,00 \cdot (v + g) + 1,00 \cdot (s2) + 1,00 \cdot (k6)$

299 (comb279)	$1,00 \cdot (v + g) + 1,00 \cdot (s2) + 1,00 \cdot (k7)$
300 (comb280)	$1,00 \cdot (v + g) + 1,00 \cdot (s2) + 1,00 \cdot (k8)$
301 (comb281)	$1,00 \cdot (v + g) + 1,00 \cdot (s2) + 1,00 \cdot (k9)$
302 (comb282)	$1,00 \cdot (v + g) + 1,00 \cdot (s2) + 1,00 \cdot (k10)$
303 (comb283)	$1,00 \cdot (v + g) + 1,00 \cdot (s2) + 1,00 \cdot (k11)$
304 (comb284)	$1,00 \cdot (v + g) + 1,00 \cdot (s2) + 1,00 \cdot (k12)$
305 (comb285)	$1,00 \cdot (v + g) + 1,00 \cdot (s1) + 1,00 \cdot 0,6 \cdot (w1) + 1,00 \cdot (k1)$
306 (comb286)	$1,00 \cdot (v + g) + 1,00 \cdot (s1) + 1,00 \cdot 0,6 \cdot (w1) + 1,00 \cdot (k2)$
307 (comb287)	$1,00 \cdot (v + g) + 1,00 \cdot (s1) + 1,00 \cdot 0,6 \cdot (w1) + 1,00 \cdot (k3)$
308 (comb288)	$1,00 \cdot (v + g) + 1,00 \cdot (s1) + 1,00 \cdot 0,6 \cdot (w1) + 1,00 \cdot (k4)$
309 (comb289)	$1,00 \cdot (v + g) + 1,00 \cdot (s1) + 1,00 \cdot 0,6 \cdot (w1) + 1,00 \cdot (k5)$
310 (comb290)	$1,00 \cdot (v + g) + 1,00 \cdot (s1) + 1,00 \cdot 0,6 \cdot (w1) + 1,00 \cdot (k6)$
311 (comb291)	$1,00 \cdot (v + g) + 1,00 \cdot (s1) + 1,00 \cdot 0,6 \cdot (w1) + 1,00 \cdot (k7)$
312 (comb292)	$1,00 \cdot (v + g) + 1,00 \cdot (s1) + 1,00 \cdot 0,6 \cdot (w1) + 1,00 \cdot (k8)$
313 (comb293)	$1,00 \cdot (v + g) + 1,00 \cdot (s1) + 1,00 \cdot 0,6 \cdot (w1) + 1,00 \cdot (k9)$
314 (comb294)	$1,00 \cdot (v + g) + 1,00 \cdot (s1) + 1,00 \cdot 0,6 \cdot (w1) + 1,00 \cdot (k10)$
315 (comb295)	$1,00 \cdot (v + g) + 1,00 \cdot (s1) + 1,00 \cdot 0,6 \cdot (w1) + 1,00 \cdot (k11)$
316 (comb296)	$1,00 \cdot (v + g) + 1,00 \cdot (s1) + 1,00 \cdot 0,6 \cdot (w1) + 1,00 \cdot (k12)$
317 (comb297)	$1,00 \cdot (v + g) + 1,00 \cdot (s1) + 1,00 \cdot 0,6 \cdot (w2) + 1,00 \cdot (k1)$
318 (comb298)	$1,00 \cdot (v + g) + 1,00 \cdot (s1) + 1,00 \cdot 0,6 \cdot (w2) + 1,00 \cdot (k2)$
319 (comb299)	$1,00 \cdot (v + g) + 1,00 \cdot (s1) + 1,00 \cdot 0,6 \cdot (w2) + 1,00 \cdot (k3)$
320 (comb300)	$1,00 \cdot (v + g) + 1,00 \cdot (s1) + 1,00 \cdot 0,6 \cdot (w2) + 1,00 \cdot (k4)$
321 (comb301)	$1,00 \cdot (v + g) + 1,00 \cdot (s1) + 1,00 \cdot 0,6 \cdot (w2) + 1,00 \cdot (k5)$
322 (comb302)	$1,00 \cdot (v + g) + 1,00 \cdot (s1) + 1,00 \cdot 0,6 \cdot (w2) + 1,00 \cdot (k6)$
323 (comb303)	$1,00 \cdot (v + g) + 1,00 \cdot (s1) + 1,00 \cdot 0,6 \cdot (w2) + 1,00 \cdot (k7)$
324 (comb304)	$1,00 \cdot (v + g) + 1,00 \cdot (s1) + 1,00 \cdot 0,6 \cdot (w2) + 1,00 \cdot (k8)$
325 (comb305)	$1,00 \cdot (v + g) + 1,00 \cdot (s1) + 1,00 \cdot 0,6 \cdot (w2) + 1,00 \cdot (k9)$
326 (comb306)	$1,00 \cdot (v + g) + 1,00 \cdot (s1) + 1,00 \cdot 0,6 \cdot (w2) + 1,00 \cdot (k10)$
327 (comb307)	$1,00 \cdot (v + g) + 1,00 \cdot (s1) + 1,00 \cdot 0,6 \cdot (w2) + 1,00 \cdot (k11)$
328 (comb308)	$1,00 \cdot (v + g) + 1,00 \cdot (s1) + 1,00 \cdot 0,6 \cdot (w2) + 1,00 \cdot (k12)$
329 (comb309)	$1,00 \cdot (v + g) + 1,00 \cdot (s1) + 1,00 \cdot 0,6 \cdot (w3) + 1,00 \cdot (k1)$
330 (comb310)	$1,00 \cdot (v + g) + 1,00 \cdot (s1) + 1,00 \cdot 0,6 \cdot (w3) + 1,00 \cdot (k2)$

331 (comb311)	$1,00 \cdot (v + g) + 1,00 \cdot (s1) + 1,00 \cdot 0,6 \cdot (w3) + 1,00 \cdot (k3)$
332 (comb312)	$1,00 \cdot (v + g) + 1,00 \cdot (s1) + 1,00 \cdot 0,6 \cdot (w3) + 1,00 \cdot (k4)$
333 (comb313)	$1,00 \cdot (v + g) + 1,00 \cdot (s1) + 1,00 \cdot 0,6 \cdot (w3) + 1,00 \cdot (k5)$
334 (comb314)	$1,00 \cdot (v + g) + 1,00 \cdot (s1) + 1,00 \cdot 0,6 \cdot (w3) + 1,00 \cdot (k6)$
335 (comb315)	$1,00 \cdot (v + g) + 1,00 \cdot (s1) + 1,00 \cdot 0,6 \cdot (w3) + 1,00 \cdot (k7)$
336 (comb316)	$1,00 \cdot (v + g) + 1,00 \cdot (s1) + 1,00 \cdot 0,6 \cdot (w3) + 1,00 \cdot (k8)$
337 (comb317)	$1,00 \cdot (v + g) + 1,00 \cdot (s1) + 1,00 \cdot 0,6 \cdot (w3) + 1,00 \cdot (k9)$
338 (comb318)	$1,00 \cdot (v + g) + 1,00 \cdot (s1) + 1,00 \cdot 0,6 \cdot (w3) + 1,00 \cdot (k10)$
339 (comb319)	$1,00 \cdot (v + g) + 1,00 \cdot (s1) + 1,00 \cdot 0,6 \cdot (w3) + 1,00 \cdot (k11)$
340 (comb320)	$1,00 \cdot (v + g) + 1,00 \cdot (s1) + 1,00 \cdot 0,6 \cdot (w3) + 1,00 \cdot (k12)$
341 (comb321)	$1,00 \cdot (v + g) + 1,00 \cdot (s1) + 1,00 \cdot 0,6 \cdot (w4) + 1,00 \cdot (k1)$
342 (comb322)	$1,00 \cdot (v + g) + 1,00 \cdot (s1) + 1,00 \cdot 0,6 \cdot (w4) + 1,00 \cdot (k2)$
343 (comb323)	$1,00 \cdot (v + g) + 1,00 \cdot (s1) + 1,00 \cdot 0,6 \cdot (w4) + 1,00 \cdot (k3)$
344 (comb324)	$1,00 \cdot (v + g) + 1,00 \cdot (s1) + 1,00 \cdot 0,6 \cdot (w4) + 1,00 \cdot (k4)$
345 (comb325)	$1,00 \cdot (v + g) + 1,00 \cdot (s1) + 1,00 \cdot 0,6 \cdot (w4) + 1,00 \cdot (k5)$
346 (comb326)	$1,00 \cdot (v + g) + 1,00 \cdot (s1) + 1,00 \cdot 0,6 \cdot (w4) + 1,00 \cdot (k6)$
347 (comb327)	$1,00 \cdot (v + g) + 1,00 \cdot (s1) + 1,00 \cdot 0,6 \cdot (w4) + 1,00 \cdot (k7)$
348 (comb328)	$1,00 \cdot (v + g) + 1,00 \cdot (s1) + 1,00 \cdot 0,6 \cdot (w4) + 1,00 \cdot (k8)$
349 (comb329)	$1,00 \cdot (v + g) + 1,00 \cdot (s1) + 1,00 \cdot 0,6 \cdot (w4) + 1,00 \cdot (k9)$
350 (comb330)	$1,00 \cdot (v + g) + 1,00 \cdot (s1) + 1,00 \cdot 0,6 \cdot (w4) + 1,00 \cdot (k10)$
351 (comb331)	$1,00 \cdot (v + g) + 1,00 \cdot (s1) + 1,00 \cdot 0,6 \cdot (w4) + 1,00 \cdot (k11)$
352 (comb332)	$1,00 \cdot (v + g) + 1,00 \cdot (s1) + 1,00 \cdot 0,6 \cdot (w4) + 1,00 \cdot (k12)$
353 (comb333)	$1,00 \cdot (v + g) + 1,00 \cdot (s2) + 1,00 \cdot 0,6 \cdot (w1) + 1,00 \cdot (k1)$
354 (comb334)	$1,00 \cdot (v + g) + 1,00 \cdot (s2) + 1,00 \cdot 0,6 \cdot (w1) + 1,00 \cdot (k2)$
355 (comb335)	$1,00 \cdot (v + g) + 1,00 \cdot (s2) + 1,00 \cdot 0,6 \cdot (w1) + 1,00 \cdot (k3)$
356 (comb336)	$1,00 \cdot (v + g) + 1,00 \cdot (s2) + 1,00 \cdot 0,6 \cdot (w1) + 1,00 \cdot (k4)$
357 (comb337)	$1,00 \cdot (v + g) + 1,00 \cdot (s2) + 1,00 \cdot 0,6 \cdot (w1) + 1,00 \cdot (k5)$
358 (comb338)	$1,00 \cdot (v + g) + 1,00 \cdot (s2) + 1,00 \cdot 0,6 \cdot (w1) + 1,00 \cdot (k6)$
359 (comb339)	$1,00 \cdot (v + g) + 1,00 \cdot (s2) + 1,00 \cdot 0,6 \cdot (w1) + 1,00 \cdot (k7)$
360 (comb340)	$1,00 \cdot (v + g) + 1,00 \cdot (s2) + 1,00 \cdot 0,6 \cdot (w1) + 1,00 \cdot (k8)$
361 (comb341)	$1,00 \cdot (v + g) + 1,00 \cdot (s2) + 1,00 \cdot 0,6 \cdot (w1) + 1,00 \cdot (k9)$
362 (comb342)	$1,00 \cdot (v + g) + 1,00 \cdot (s2) + 1,00 \cdot 0,6 \cdot (w1) + 1,00 \cdot (k10)$

363 (comb343)	$1,00 \cdot (v + g) + 1,00 \cdot (s2) + 1,00 \cdot 0,6 \cdot (w1) + 1,00 \cdot (k11)$
364 (comb344)	$1,00 \cdot (v + g) + 1,00 \cdot (s2) + 1,00 \cdot 0,6 \cdot (w1) + 1,00 \cdot (k12)$
365 (comb345)	$1,00 \cdot (v + g) + 1,00 \cdot (s2) + 1,00 \cdot 0,6 \cdot (w2) + 1,00 \cdot (k1)$
366 (comb346)	$1,00 \cdot (v + g) + 1,00 \cdot (s2) + 1,00 \cdot 0,6 \cdot (w2) + 1,00 \cdot (k2)$
367 (comb347)	$1,00 \cdot (v + g) + 1,00 \cdot (s2) + 1,00 \cdot 0,6 \cdot (w2) + 1,00 \cdot (k3)$
368 (comb348)	$1,00 \cdot (v + g) + 1,00 \cdot (s2) + 1,00 \cdot 0,6 \cdot (w2) + 1,00 \cdot (k4)$
369 (comb349)	$1,00 \cdot (v + g) + 1,00 \cdot (s2) + 1,00 \cdot 0,6 \cdot (w2) + 1,00 \cdot (k5)$
370 (comb350)	$1,00 \cdot (v + g) + 1,00 \cdot (s2) + 1,00 \cdot 0,6 \cdot (w2) + 1,00 \cdot (k6)$
371 (comb351)	$1,00 \cdot (v + g) + 1,00 \cdot (s2) + 1,00 \cdot 0,6 \cdot (w2) + 1,00 \cdot (k7)$
372 (comb352)	$1,00 \cdot (v + g) + 1,00 \cdot (s2) + 1,00 \cdot 0,6 \cdot (w2) + 1,00 \cdot (k8)$
373 (comb353)	$1,00 \cdot (v + g) + 1,00 \cdot (s2) + 1,00 \cdot 0,6 \cdot (w2) + 1,00 \cdot (k9)$
374 (comb354)	$1,00 \cdot (v + g) + 1,00 \cdot (s2) + 1,00 \cdot 0,6 \cdot (w2) + 1,00 \cdot (k10)$
375 (comb355)	$1,00 \cdot (v + g) + 1,00 \cdot (s2) + 1,00 \cdot 0,6 \cdot (w2) + 1,00 \cdot (k11)$
376 (comb356)	$1,00 \cdot (v + g) + 1,00 \cdot (s2) + 1,00 \cdot 0,6 \cdot (w2) + 1,00 \cdot (k12)$
377 (comb357)	$1,00 \cdot (v + g) + 1,00 \cdot (s2) + 1,00 \cdot 0,6 \cdot (w3) + 1,00 \cdot (k1)$
378 (comb358)	$1,00 \cdot (v + g) + 1,00 \cdot (s2) + 1,00 \cdot 0,6 \cdot (w3) + 1,00 \cdot (k2)$
379 (comb359)	$1,00 \cdot (v + g) + 1,00 \cdot (s2) + 1,00 \cdot 0,6 \cdot (w3) + 1,00 \cdot (k3)$
380 (comb360)	$1,00 \cdot (v + g) + 1,00 \cdot (s2) + 1,00 \cdot 0,6 \cdot (w3) + 1,00 \cdot (k4)$
381 (comb361)	$1,00 \cdot (v + g) + 1,00 \cdot (s2) + 1,00 \cdot 0,6 \cdot (w3) + 1,00 \cdot (k5)$
382 (comb362)	$1,00 \cdot (v + g) + 1,00 \cdot (s2) + 1,00 \cdot 0,6 \cdot (w3) + 1,00 \cdot (k6)$
383 (comb363)	$1,00 \cdot (v + g) + 1,00 \cdot (s2) + 1,00 \cdot 0,6 \cdot (w3) + 1,00 \cdot (k7)$
384 (comb364)	$1,00 \cdot (v + g) + 1,00 \cdot (s2) + 1,00 \cdot 0,6 \cdot (w3) + 1,00 \cdot (k8)$
385 (comb365)	$1,00 \cdot (v + g) + 1,00 \cdot (s2) + 1,00 \cdot 0,6 \cdot (w3) + 1,00 \cdot (k9)$
386 (comb366)	$1,00 \cdot (v + g) + 1,00 \cdot (s2) + 1,00 \cdot 0,6 \cdot (w3) + 1,00 \cdot (k10)$
387 (comb367)	$1,00 \cdot (v + g) + 1,00 \cdot (s2) + 1,00 \cdot 0,6 \cdot (w3) + 1,00 \cdot (k11)$
388 (comb368)	$1,00 \cdot (v + g) + 1,00 \cdot (s2) + 1,00 \cdot 0,6 \cdot (w3) + 1,00 \cdot (k12)$
389 (comb369)	$1,00 \cdot (v + g) + 1,00 \cdot (s2) + 1,00 \cdot 0,6 \cdot (w4) + 1,00 \cdot (k1)$
390 (comb370)	$1,00 \cdot (v + g) + 1,00 \cdot (s2) + 1,00 \cdot 0,6 \cdot (w4) + 1,00 \cdot (k2)$
391 (comb371)	$1,00 \cdot (v + g) + 1,00 \cdot (s2) + 1,00 \cdot 0,6 \cdot (w4) + 1,00 \cdot (k3)$
392 (comb372)	$1,00 \cdot (v + g) + 1,00 \cdot (s2) + 1,00 \cdot 0,6 \cdot (w4) + 1,50 \cdot (k4)$
391 (comb373)	$1,00 \cdot (v + g) + 1,00 \cdot (s2) + 1,00 \cdot 0,6 \cdot (w4) + 1,00 \cdot (k5)$
394 (comb374)	$1,00 \cdot (v + g) + 1,00 \cdot (s2) + 1,00 \cdot 0,6 \cdot (w4) + 1,00 \cdot (k6)$

395 (comb375)	$1,00 \cdot (v + g) + 1,00 \cdot (s2) + 1,00 \cdot 0,6 \cdot (w4) + 1,00 \cdot (k7)$
396 (comb376)	$1,00 \cdot (v + g) + 1,00 \cdot (s2) + 1,00 \cdot 0,6 \cdot (w4) + 1,00 \cdot (k8)$
397 (comb377)	$1,00 \cdot (v + g) + 1,00 \cdot (s2) + 1,00 \cdot 0,6 \cdot (w4) + 1,00 \cdot (k9)$
398 (comb378)	$1,00 \cdot (v + g) + 1,00 \cdot (s2) + 1,00 \cdot 0,6 \cdot (w4) + 1,00 \cdot (k10)$
399 (comb379)	$1,00 \cdot (v + g) + 1,00 \cdot (s2) + 1,00 \cdot 0,6 \cdot (w4) + 1,00 \cdot (k11)$
400 (comb380)	$1,00 \cdot (v + g) + 1,00 \cdot (s2) + 1,00 \cdot 0,6 \cdot (w4) + 1,00 \cdot (k12)$
401 (comb381)	$1,00 \cdot (v + g) + 1,00 \cdot (w1) + 1,00 \cdot 0,5 \cdot (s1) + 1,00 \cdot (k1)$
402 (comb382)	$1,00 \cdot (v + g) + 1,00 \cdot (w1) + 1,00 \cdot 0,5 \cdot (s1) + 1,00 \cdot (k2)$
403 (comb383)	$1,00 \cdot (v + g) + 1,00 \cdot (w1) + 1,00 \cdot 0,5 \cdot (s1) + 1,00 \cdot (k3)$
404 (comb384)	$1,00 \cdot (v + g) + 1,00 \cdot (w1) + 1,00 \cdot 0,5 \cdot (s1) + 1,00 \cdot (k4)$
405 (comb385)	$1,00 \cdot (v + g) + 1,00 \cdot (w1) + 1,00 \cdot 0,5 \cdot (s1) + 1,00 \cdot (k5)$
406 (comb386)	$1,00 \cdot (v + g) + 1,00 \cdot (w1) + 1,00 \cdot 0,5 \cdot (s1) + 1,00 \cdot (k6)$
407 (comb387)	$1,00 \cdot (v + g) + 1,00 \cdot (w1) + 1,00 \cdot 0,5 \cdot (s1) + 1,00 \cdot (k7)$
408 (comb388)	$1,00 \cdot (v + g) + 1,00 \cdot (w1) + 1,00 \cdot 0,5 \cdot (s1) + 1,00 \cdot (k8)$
409 (comb389)	$1,00 \cdot (v + g) + 1,00 \cdot (w1) + 1,00 \cdot 0,5 \cdot (s1) + 1,00 \cdot (k9)$
410 (comb390)	$1,00 \cdot (v + g) + 1,00 \cdot (w1) + 1,00 \cdot 0,5 \cdot (s1) + 1,00 \cdot (k10)$
411 (comb391)	$1,00 \cdot (v + g) + 1,00 \cdot (w1) + 1,00 \cdot 0,5 \cdot (s1) + 1,00 \cdot (k11)$
412 (comb392)	$1,00 \cdot (v + g) + 1,00 \cdot (w1) + 1,00 \cdot 0,5 \cdot (s1) + 1,00 \cdot (k12)$
413 (comb393)	$1,00 \cdot (v + g) + 1,00 \cdot (w2) + 1,00 \cdot 0,5 \cdot (s1) + 1,00 \cdot (k1)$
414 (comb394)	$1,00 \cdot (v + g) + 1,00 \cdot (w2) + 1,00 \cdot 0,5 \cdot (s1) + 1,00 \cdot (k2)$
415 (comb395)	$1,00 \cdot (v + g) + 1,00 \cdot (w2) + 1,00 \cdot 0,5 \cdot (s1) + 1,00 \cdot (k3)$
416 (comb396)	$1,00 \cdot (v + g) + 1,00 \cdot (w2) + 1,00 \cdot 0,5 \cdot (s1) + 1,00 \cdot (k4)$
417 (comb397)	$1,00 \cdot (v + g) + 1,00 \cdot (w2) + 1,00 \cdot 0,5 \cdot (s1) + 1,00 \cdot (k5)$
418 (comb398)	$1,00 \cdot (v + g) + 1,00 \cdot (w2) + 1,00 \cdot 0,5 \cdot (s1) + 1,00 \cdot (k6)$
419 (comb399)	$1,00 \cdot (v + g) + 1,00 \cdot (w2) + 1,00 \cdot 0,5 \cdot (s1) + 1,00 \cdot (k7)$
420 (comb400)	$1,00 \cdot (v + g) + 1,00 \cdot (w2) + 1,00 \cdot 0,5 \cdot (s1) + 1,00 \cdot (k8)$
421 (comb401)	$1,00 \cdot (v + g) + 1,00 \cdot (w2) + 1,00 \cdot 0,5 \cdot (s1) + 1,00 \cdot (k9)$
422 (comb402)	$1,00 \cdot (v + g) + 1,00 \cdot (w2) + 1,00 \cdot 0,5 \cdot (s1) + 1,00 \cdot (k10)$
423 (comb403)	$1,00 \cdot (v + g) + 1,00 \cdot (w2) + 1,00 \cdot 0,5 \cdot (s1) + 1,00 \cdot (k11)$
424 (comb404)	$1,00 \cdot (v + g) + 1,00 \cdot (w2) + 1,00 \cdot 0,5 \cdot (s1) + 1,00 \cdot (k12)$
425 (comb405)	$1,00 \cdot (v + g) + 1,00 \cdot (w3) + 1,00 \cdot 0,5 \cdot (s1) + 1,00 \cdot (k1)$
426 (comb406)	$1,00 \cdot (v + g) + 1,00 \cdot (w3) + 1,00 \cdot 0,5 \cdot (s1) + 1,00 \cdot (k2)$

427 (comb407)	$1,00 \cdot (v + g) + 1,00 \cdot (w3) + 1,00 \cdot 0,5 \cdot (s1) + 1,00 \cdot (k3)$
428 (comb408)	$1,00 \cdot (v + g) + 1,00 \cdot (w3) + 1,00 \cdot 0,5 \cdot (s1) + 1,00 \cdot (k4)$
429 (comb409)	$1,00 \cdot (v + g) + 1,00 \cdot (w3) + 1,00 \cdot 0,5 \cdot (s1) + 1,00 \cdot (k5)$
430 (comb410)	$1,00 \cdot (v + g) + 1,00 \cdot (w3) + 1,00 \cdot 0,5 \cdot (s1) + 1,00 \cdot (k6)$
431 (comb411)	$1,00 \cdot (v + g) + 1,00 \cdot (w3) + 1,00 \cdot 0,5 \cdot (s1) + 1,00 \cdot (k7)$
432 (comb412)	$1,00 \cdot (v + g) + 1,00 \cdot (w3) + 1,00 \cdot 0,5 \cdot (s1) + 1,00 \cdot (k8)$
433 (comb413)	$1,00 \cdot (v + g) + 1,00 \cdot (w3) + 1,00 \cdot 0,5 \cdot (s1) + 1,00 \cdot (k9)$
434 (comb414)	$1,00 \cdot (v + g) + 1,00 \cdot (w3) + 1,00 \cdot 0,5 \cdot (s1) + 1,00 \cdot (k10)$
435 (comb415)	$1,00 \cdot (v + g) + 1,00 \cdot (w3) + 1,00 \cdot 0,5 \cdot (s1) + 1,00 \cdot (k11)$
436 (comb416)	$1,00 \cdot (v + g) + 1,00 \cdot (w3) + 1,00 \cdot 0,5 \cdot (s1) + 1,00 \cdot (k12)$
437 (comb417)	$1,00 \cdot (v + g) + 1,00 \cdot (w4) + 1,00 \cdot 0,5 \cdot (s1) + 1,00 \cdot (k1)$
438 (comb418)	$1,00 \cdot (v + g) + 1,00 \cdot (w4) + 1,00 \cdot 0,5 \cdot (s1) + 1,00 \cdot (k2)$
439 (comb419)	$1,00 \cdot (v + g) + 1,00 \cdot (w4) + 1,00 \cdot 0,5 \cdot (s1) + 1,00 \cdot (k3)$
440 (comb420)	$1,00 \cdot (v + g) + 1,00 \cdot (w4) + 1,00 \cdot 0,5 \cdot (s1) + 1,00 \cdot (k4)$
441 (comb421)	$1,00 \cdot (v + g) + 1,00 \cdot (w4) + 1,00 \cdot 0,5 \cdot (s1) + 1,00 \cdot (k5)$
442 (comb422)	$1,00 \cdot (v + g) + 1,00 \cdot (w4) + 1,00 \cdot 0,5 \cdot (s1) + 1,00 \cdot (k6)$
443 (comb423)	$1,00 \cdot (v + g) + 1,00 \cdot (w4) + 1,00 \cdot 0,5 \cdot (s1) + 1,00 \cdot (k7)$
444 (comb424)	$1,00 \cdot (v + g) + 1,00 \cdot (w4) + 1,00 \cdot 0,5 \cdot (s1) + 1,00 \cdot (k8)$
445 (comb425)	$1,00 \cdot (v + g) + 1,00 \cdot (w4) + 1,00 \cdot 0,5 \cdot (s1) + 1,00 \cdot (k9)$
446 (comb426)	$1,00 \cdot (v + g) + 1,00 \cdot (w4) + 1,00 \cdot 0,5 \cdot (s1) + 1,00 \cdot (k10)$
447 (comb427)	$1,00 \cdot (v + g) + 1,00 \cdot (w4) + 1,00 \cdot 0,5 \cdot (s1) + 1,00 \cdot (k11)$
448 (comb428)	$1,00 \cdot (v + g) + 1,00 \cdot (w4) + 1,00 \cdot 0,5 \cdot (s1) + 1,00 \cdot (k12)$
449 (comb429)	$1,00 \cdot (v + g) + 1,00 \cdot (w1) + 1,00 \cdot 0,5 \cdot (s2) + 1,00 \cdot (k1)$
450 (comb430)	$1,00 \cdot (v + g) + 1,00 \cdot (w1) + 1,00 \cdot 0,5 \cdot (s2) + 1,00 \cdot (k2)$
451 (comb431)	$1,00 \cdot (v + g) + 1,00 \cdot (w1) + 1,00 \cdot 0,5 \cdot (s2) + 1,00 \cdot (k3)$
452 (comb432)	$1,00 \cdot (v + g) + 1,00 \cdot (w1) + 1,00 \cdot 0,5 \cdot (s2) + 1,00 \cdot (k4)$
453 (comb433)	$1,00 \cdot (v + g) + 1,00 \cdot (w1) + 1,00 \cdot 0,5 \cdot (s2) + 1,00 \cdot (k5)$
454 (comb434)	$1,00 \cdot (v + g) + 1,00 \cdot (w1) + 1,00 \cdot 0,5 \cdot (s2) + 1,00 \cdot (k6)$
455 (comb435)	$1,00 \cdot (v + g) + 1,00 \cdot (w1) + 1,00 \cdot 0,5 \cdot (s2) + 1,00 \cdot (k7)$
456 (comb436)	$1,00 \cdot (v + g) + 1,00 \cdot (w1) + 1,00 \cdot 0,5 \cdot (s2) + 1,00 \cdot (k8)$
457 (comb437)	$1,00 \cdot (v + g) + 1,00 \cdot (w1) + 1,00 \cdot 0,5 \cdot (s2) + 1,00 \cdot (k9)$
458 (comb438)	$1,00 \cdot (v + g) + 1,00 \cdot (w1) + 1,00 \cdot 0,5 \cdot (s2) + 1,00 \cdot (k10)$

459 (comb439)	$1,00 \cdot (v + g) + 1,00 \cdot (w1) + 1,00 \cdot 0,5 \cdot (s2) + 1,00 \cdot (k11)$
460 (comb440)	$1,00 \cdot (v + g) + 1,00 \cdot (w1) + 1,00 \cdot 0,5 \cdot (s2) + 1,00 \cdot (k12)$
461 (comb441)	$1,00 \cdot (v + g) + 1,00 \cdot (w2) + 1,00 \cdot 0,5 \cdot (s2) + 1,00 \cdot (k1)$
462 (comb442)	$1,00 \cdot (v + g) + 1,00 \cdot (w2) + 1,00 \cdot 0,5 \cdot (s2) + 1,00 \cdot (k2)$
463 (comb443)	$1,00 \cdot (v + g) + 1,00 \cdot (w2) + 1,00 \cdot 0,5 \cdot (s2) + 1,00 \cdot (k3)$
464 (comb444)	$1,00 \cdot (v + g) + 1,00 \cdot (w2) + 1,00 \cdot 0,5 \cdot (s2) + 1,00 \cdot (k4)$
465 (comb445)	$1,00 \cdot (v + g) + 1,00 \cdot (w2) + 1,00 \cdot 0,5 \cdot (s2) + 1,00 \cdot (k5)$
466 (comb446)	$1,00 \cdot (v + g) + 1,00 \cdot (w2) + 1,00 \cdot 0,5 \cdot (s2) + 1,00 \cdot (k6)$
467 (comb447)	$1,00 \cdot (v + g) + 1,00 \cdot (w2) + 1,00 \cdot 0,5 \cdot (s2) + 1,00 \cdot (k7)$
468 (comb448)	$1,00 \cdot (v + g) + 1,00 \cdot (w2) + 1,00 \cdot 0,5 \cdot (s2) + 1,00 \cdot (k8)$
469 (comb449)	$1,00 \cdot (v + g) + 1,00 \cdot (w2) + 1,00 \cdot 0,5 \cdot (s2) + 1,00 \cdot (k9)$
470 (comb450)	$1,00 \cdot (v + g) + 1,00 \cdot (w2) + 1,00 \cdot 0,5 \cdot (s2) + 1,00 \cdot (k10)$
471 (comb451)	$1,00 \cdot (v + g) + 1,00 \cdot (w2) + 1,00 \cdot 0,5 \cdot (s2) + 1,00 \cdot (k11)$
472 (comb452)	$1,00 \cdot (v + g) + 1,00 \cdot (w2) + 1,00 \cdot 0,5 \cdot (s2) + 1,00 \cdot (k12)$
473 (comb453)	$1,00 \cdot (v + g) + 1,00 \cdot (w3) + 1,00 \cdot 0,5 \cdot (s2) + 1,00 \cdot (k1)$
474 (comb454)	$1,00 \cdot (v + g) + 1,00 \cdot (w3) + 1,00 \cdot 0,5 \cdot (s2) + 1,00 \cdot (k2)$
475 (comb455)	$1,00 \cdot (v + g) + 1,00 \cdot (w3) + 1,00 \cdot 0,5 \cdot (s2) + 1,00 \cdot (k3)$
476 (comb456)	$1,00 \cdot (v + g) + 1,00 \cdot (w3) + 1,00 \cdot 0,5 \cdot (s2) + 1,00 \cdot (k4)$
477 (comb457)	$1,00 \cdot (v + g) + 1,00 \cdot (w3) + 1,00 \cdot 0,5 \cdot (s2) + 1,00 \cdot (k5)$
478 (comb458)	$1,00 \cdot (v + g) + 1,00 \cdot (w3) + 1,00 \cdot 0,5 \cdot (s2) + 1,00 \cdot (k6)$
479 (comb459)	$1,00 \cdot (v + g) + 1,00 \cdot (w3) + 1,00 \cdot 0,5 \cdot (s2) + 1,00 \cdot (k7)$
480 (comb460)	$1,00 \cdot (v + g) + 1,00 \cdot (w3) + 1,00 \cdot 0,5 \cdot (s2) + 1,00 \cdot (k8)$
481 (comb461)	$1,00 \cdot (v + g) + 1,00 \cdot (w3) + 1,00 \cdot 0,5 \cdot (s2) + 1,00 \cdot (k9)$
482 (comb462)	$1,00 \cdot (v + g) + 1,00 \cdot (w3) + 1,00 \cdot 0,5 \cdot (s2) + 1,00 \cdot (k10)$
483 (comb463)	$1,00 \cdot (v + g) + 1,00 \cdot (w3) + 1,00 \cdot 0,5 \cdot (s2) + 1,00 \cdot (k11)$
484 (comb464)	$1,00 \cdot (v + g) + 1,00 \cdot (w3) + 1,00 \cdot 0,5 \cdot (s2) + 1,00 \cdot (k12)$
485 (comb465)	$1,00 \cdot (v + g) + 1,00 \cdot (w4) + 1,00 \cdot 0,5 \cdot (s2) + 1,00 \cdot (k1)$
486 (comb466)	$1,00 \cdot (v + g) + 1,00 \cdot (w4) + 1,00 \cdot 0,5 \cdot (s2) + 1,00 \cdot (k2)$
487 (comb467)	$1,00 \cdot (v + g) + 1,00 \cdot (w4) + 1,00 \cdot 0,5 \cdot (s2) + 1,00 \cdot (k3)$
488 (comb468)	$1,00 \cdot (v + g) + 1,00 \cdot (w4) + 1,00 \cdot 0,5 \cdot (s2) + 1,00 \cdot (k4)$
489 (comb469)	$1,00 \cdot (v + g) + 1,00 \cdot (w4) + 1,00 \cdot 0,5 \cdot (s2) + 1,00 \cdot (k5)$
490 (comb470)	$1,00 \cdot (v + g) + 1,00 \cdot (w4) + 1,00 \cdot 0,5 \cdot (s2) + 1,00 \cdot (k6)$

491 (comb471)	$1,00 \cdot (v + g) + 1,00 \cdot (w4) + 1,00 \cdot 0,5 \cdot (s2) + 1,00 \cdot (k7)$
492 (comb472)	$1,00 \cdot (v + g) + 1,00 \cdot (w4) + 1,00 \cdot 0,5 \cdot (s2) + 1,00 \cdot (k8)$
493 (comb473)	$1,00 \cdot (v + g) + 1,00 \cdot (w4) + 1,00 \cdot 0,5 \cdot (s2) + 1,00 \cdot (k9)$
494 (comb474)	$1,00 \cdot (v + g) + 1,00 \cdot (w4) + 1,00 \cdot 0,5 \cdot (s2) + 1,00 \cdot (k10)$
495 (comb475)	$1,00 \cdot (v + g) + 1,00 \cdot (w4) + 1,00 \cdot 0,5 \cdot (s2) + 1,00 \cdot (k11)$
496 (comb476)	$1,00 \cdot (v + g) + 1,00 \cdot (w4) + 1,00 \cdot 0,5 \cdot (s2) + 1,00 \cdot (k12)$

6. REZULTATI

6.1. Rezne sile

U Tablicama 6. – 20. prikazane su maksimalne rezne sile pojedinih elemenata konstrukcije

Tablica 6. Maksimalne rezne sile vanjskih stupova [izradio autor]

	FX (kN)	FY (kN)	FZ (kN)	MX (kNm)	MY (kNm)	MZ (kNm)
MAX	432,65	58,24	51,83	0,57	155,06	0,65
Member	24	17	8	66	38	57
Node	29	22	10	78	46	66
Case	57 (C)	231 (C)	25 (C)	150 (C)	127 (C)	238 (C)
MIN	-81,49	-59,02	-64,29	-0,66	-146,27	-0,60
Member	66	10	8	17	36	24
Node	77	13	10	22	42	30
Case	8	208 (C)	233 (C)	231 (C)	64 (C)	229 (C)

Tablica 7. Maksimalne rezne sile vanjskih zabatnih stupova [izradio autor]

	FX (kN)	FY (kN)	FZ (kN)	MX (kNm)	MY (kNm)	MZ (kNm)
MAX	343,07	18,67	88,25	0,25	28,32	0,17
Member	73	3	1	1	3	73
Node	85	6	1	2	6	86
Case	223 (C)	30 (C)	227 (C)	42 (C)	227 (C)	138 (C)
MIN	-164,11	-26,86	-46,88	-0,25	-9,79	-0,18
Member	1	73	1	3	1	3
Node	1	85	2	6	2	6
Case	227 (C)	235 (C)	60 (C)	42 (C)	60 (C)	127 (C)

Tablica 8. Maksimalne rezne sile unutarnjih stupova [izradio autor]

	FX (kN)	FY (kN)	FZ (kN)	MX (kNm)	MY (kNm)	MZ (kNm)
MAX	594,67	11,01	12,72	0,19	75,65	0,89
Member	23	23	23	23	23	9
Node	27	28	28	28	28	12
Case	58 (C)	254 (C)	176 (C)	66 (C)	176 (C)	36 (C)
MIN	-92,94	-2,45	-7,93	-0,16	-12,75	-2,33
Member	9	23	23	16	30	9
Node	11	27	28	20	36	12
Case	7	254 (C)	235 (C)	186 (C)	246 (C)	206 (C)

Tablica 9. Maksimalne rezne sile grednih nosača [izradio autor]

	FX (kN)	FY (kN)	FZ (kN)	MX (kNm)	MY (kNm)	MZ (kNm)
MAX	164,72	54,54	36,51	1,02	178,25	2,60
Member	70	70	42	28	35	18
Node	76	80	44	28	40	20
Case	146 (C)	234 (C)	5	194 (C)	141 (C)	170 (C)
MIN	-95,34	-58,24	-107,53	-1,03	-334,06	-2,50
Member	14	20	35	25	25	21
Node	12	22	36	28	28	20
Case	7	231 (C)	56 (C)	194 (C)	140 (C)	170 (C)

Tablica 10. Maksimalne rezne sile grednih zabatnih nosača [izradio autor]

	FX (kN)	FY (kN)	FZ (kN)	MX (kNm)	MY (kNm)	MZ (kNm)
MAX	87,07	25,12	10,70	0,27	25,57	1,31
Member	6	76	75	7	5	5
Node	6	86	82	4	7	7
Case	227 (C)	246 (C)	5	130 (C)	61 (C)	248 (C)
MIN	-127,19	-24,47	-22,30	-0,27	-32,28	-1,32
Member	77	75	4	4	4	4
Node	84	82	4	4	4	7
Case	246 (C)	238 (C)	227 (C)	130 (C)	227 (C)	248 (C)

Tablica 11. Maksimalne rezne sile podrožnica [izradio autor]

	FX (kN)	FY (kN)	FZ (kN)	MX (kNm)	MY (kNm)	MZ (kNm)
MAX	119,57	0,90	11,88	0,02	9,95	2,73
Member	247	254	274	233	322	254
Node	226	294	208	282	353	294
Case	223 (C)	223 (C)	56 (C)	63 (C)	23 (C)	223 (C)
MIN	-157,63	-0,89	-14,86	-0,02	-14,75	-2,70
Member	227	261	268	277	324	254
Node	227	301	198	314	198	295
Case	223 (C)	231 (C)	62 (C)	61 (C)	62 (C)	223 (C)

Tablica 12. Maksimalne rezne sile zabatnih stupova [izradio autor]

	FX (kN)	FY (kN)	FZ (kN)	MX (kNm)	MY (kNm)	MZ (kNm)
MAX	260,44	28,83	26,18	0,04	1,24	4,47
Member	129	129	138	125	129	135
Node	154	154	172	147	155	167
Case	227 (C)	227 (C)	248 (C)	26 (C)	23 (C)	154 (C)
MIN	-132,49	-7,22	-20,89	-0,04	-1,45	-6,48
Member	124	140	126	137	129	123
Node	144	177	149	171	155	143
Case	24 (C)	142 (C)	250 (C)	26 (C)	42 (C)	227 (C)

Tablica 13. Maksimalne rezne sile krovnih uzdužnih vezova [izradio autor]

	FX (kN)	FY (kN)	FZ (kN)	MX (kNm)	MY (kNm)	MZ (kNm)
MAX	80,55	0,00	0,18	0,0	0,0	0,0
Member	167	197	199	147	147	147
Node	190	245	250	188	188	188
Case	223 (C)	23 (C)	21 (C)	1	1	1
MIN	-86,58	-0,00	-0,18	0,0	0,0	0,0
Member	168	170	199	147	147	147
Node	188	207	247	188	188	188
Case	223 (C)	175 (C)	21 (C)	1	1	1

Tablica 14. Maksimalne rezne sile krovnih poprečnih vezova [izradio autor]

	FX (kN)	FY (kN)	FZ (kN)	MX (kNm)	MY (kNm)	MZ (kNm)
MAX	85,46	0,00	0,18	0,0	0,0	0,0
Member	222	147	199	147	147	147
Node	250	188	250	188	188	188
Case	234 (C)	130 (C)	21 (C)	1	1	1
MIN	-84,78	-0,00	-0,18	0,0	0,0	0,0
Member	221	160	199	147	147	147
Node	280	207	247	188	188	188
Case	234 (C)	23 (C)	21 (C)	1	1	1

Tablica 15. Maksimalne rezne sile vertikalnih uzdužnih vezova [izradio autor]

	FX (kN)	FY (kN)	FZ (kN)	MX (kNm)	MY (kNm)	MZ (kNm)
MAX	64,00	0,00	0,15	0,00	0,00	0,01
Member	203	146	164	146	163	210
Node	255	187	214	187	213	260
Case	235 (C)	123 (C)	248 (C)	219 (C)	8	36 (C)
MIN	-59,64	-0,00	-0,15	-0,00	-0,21	-0,01
Member	206	205	143	205	143	165
Node	258	257	183	257	183	215
Case	235 (C)	28 (C)	247 (C)	211 (C)	255 (C)	216 (C)

Tablica 16. Maksimalne rezne sile vertikalnih poprečnih vezova [izradio autor]

	FX (kN)	FY (kN)	FZ (kN)	MX (kNm)	MY (kNm)	MZ (kNm)
MAX	96,10	0,00	0,09	0,00	0,01	0,01
Member	655	654	659	654	654	661
Node	185	182	592	182	558	217
Case	227 (C)	205 (C)	227 (C)	211 (C)	6	199 (C)
MIN	-95,83	-0,00	-0,08	-0,00	-0,07	-0,01
Member	658	659	658	663	659	656
Node	213	215	586	258	592	186
Case	227 (C)	205 (C)	227 (C)	36 (C)	227 (C)	200 (C)

Tablica 17. Maksimalne rezne sile zabatnih horizontalnih nosača obloge [izradio autor]

	FX (kN)	FY (kN)	FZ (kN)	MX (kNm)	MY (kNm)	MZ (kNm)
MAX	45,31	5,94	18,09	0,04	35,25	3,34
Member	521	522	532	470	537	625
Node	553	559	571	186	571	652
Case	227 (C)	192 (C)	214 (C)	200 (C)	214 (C)	7
MIN	-63,53	-6,73	-17,30	-0,04	-31,55	-5,57
Member	557	522	537	553	532	522
Node	582	555	571	591	571	555
Case	227 (C)	227 (C)	214 (C)	247 (C)	41 (C)	227 (C)

Tablica 18. Maksimalne rezne sile uzdužnih horizontalnih nosača obloge [izradio autor]

	FX (kN)	FY (kN)	FZ (kN)	MX (kNm)	MY (kNm)	MZ (kNm)
MAX	96,26	9,15	14,62	0,02	16,62	0,69
Member	583	464	559	562	605	466
Node	613	184	596	213	260	185
Case	24 (C)	247 (C)	25 (C)	240 (C)	40 (C)	8
MIN	-133,46	-8,97	-14,86	-0,02	-18,51	-9,65
Member	486	513	463	466	464	464
Node	512	254	495	185	182	184
Case	231 (C)	38 (C)	25 (C)	243 (C)	211 (C)	247 (C)

Tablica 19. Maksimalne rezne sile konzole [izradio autor]

	FX (kN)	FY (kN)	FZ (kN)	MX (kNm)	MY (kNm)	MZ (kNm)
MAX	19,22	66,18	263,97	0,28	7,94	11,32
Member	437	424	437	424	439	91
Node	450	428	450	428	453	106
Case	226 (C)	113 (C)	214 (C)	208 (C)	174 (C)	218 (C)
MIN	-5,41	-67,82	-19,58	-0,27	-102,55	-11,19
Member	424	437	433	423	437	102
Node	428	450	444	426	450	106
Case	190 (C)	234 (C)	254 (C)	229 (C)	164 (C)	218 (C)

Tablica 20. Maksimalne rezne sile kranske staze [izradio autor]

	FX (kN)	FY (kN)	FZ (kN)	MX (kNm)	MY (kNm)	MZ (kNm)
MAX	90,86	45,29	152,47	1,59	22,77	17,35
Member	82	91	82	104	106	82
Node	96	106	93	121	122	96
Case	147 (C)	214 (C)	113 (C)	210 (C)	230 (C)	65 (C)
MIN	-75,49	-36,29	-166,29	-1,59	-132,12	-21,69
Member	105	91	82	82	82	104
Node	122	106	96	96	96	121
Case	219 (C)	41 (C)	113 (C)	183 (C)	113 (C)	234 (C)

7. Dimenzioniranje elemenata konstrukcije

7.1. Vanjski stupovi

Na Slici 39. prikazan je položaj mjerodavnog vanjskog stupa za dimenzioniranje, te vrijednosti na dijagramima za karakterističnu kombinaciju 141 (COMB121)

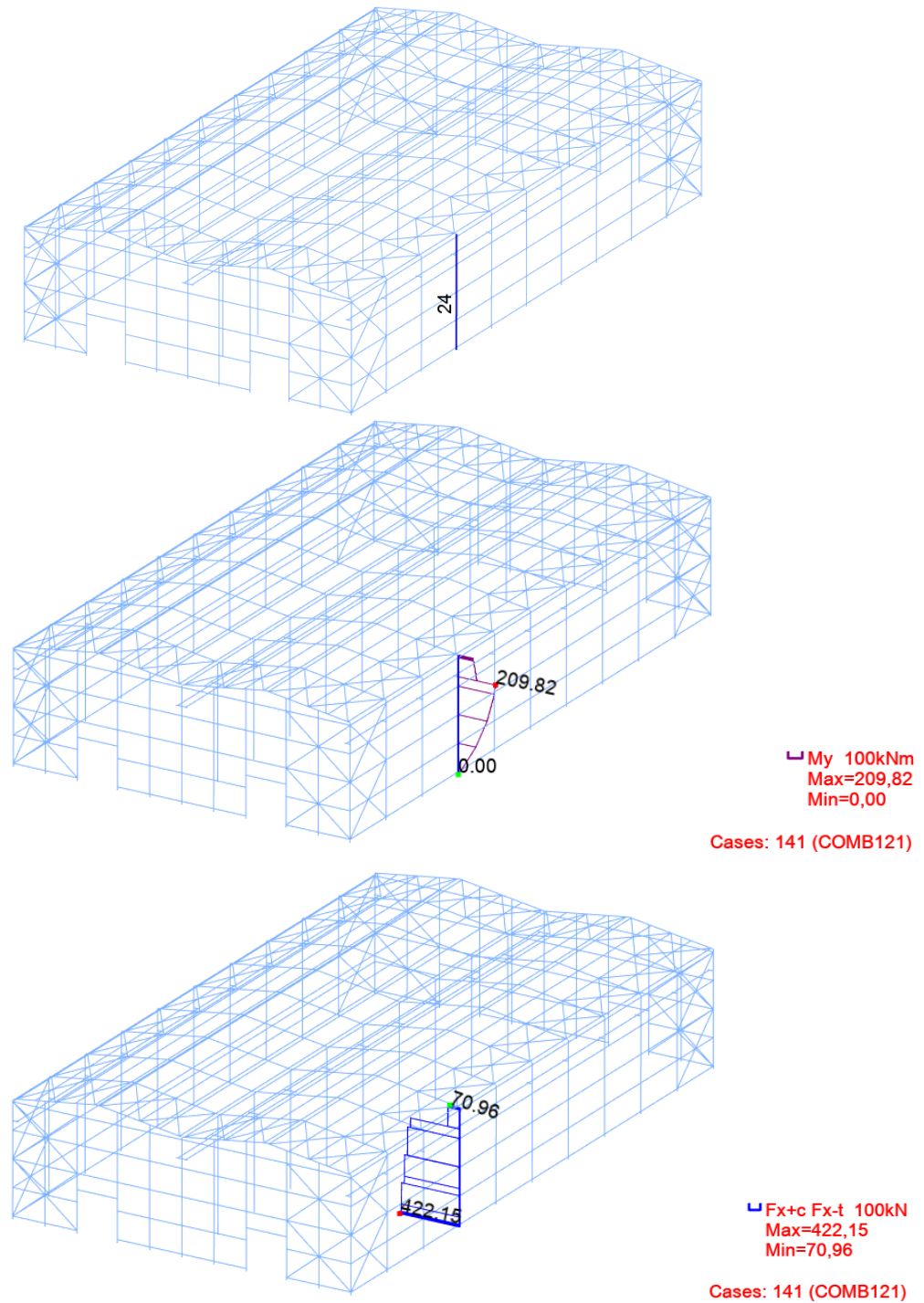

Slika 39. Položaj i vrijednosti dijagrama na vanjskom stupu mjerodavnom za dimenzioniranje [izradio autor]

STEEL DESIGN

CODE: EN 1993-1:2005/A1:2014, Eurocode 3: Design of steel structures.

ANALYSIS TYPE: Member Verification

CODE GROUP:

MEMBER: 24

POINT: 3

COORDINATE: x = 0.82 L = 9.00

m

LOADS:

Governing Load Case: 141 COMB121 (1+2)*1.35+(4+11)*1.50+7*0.90

MATERIAL:

S 275 (S 275) $f_y = 275.00$ MPa



SECTION PARAMETERS: HEA 340

h=330 mm	gM0=1.00	gM1=1.10	
b=300 mm	Ay=11039 mm ²	Az=4495 mm ²	Ax=13347 mm ²
tw=10 mm	Iy=276931000 mm ⁴	Iz=74360000 mm ⁴	Ix=1230000 mm ⁴
tf=17 mm	Wply=1850620 mm ³	Wplz=755963 mm ³	

INTERNAL FORCES AND CAPACITIES:

N,Ed = 346.54 kN	My,Ed = 209.82 kN*m	Mz,Ed = 9.05 kN*m	Vy,Ed = -6.99 kN
Nc,Rd = 3670.51 kN	My,Ed,max = 209.82 kN*m		Mz,Ed,max = 9.05 kN*m
	Vy,T,Rd = 1746.97 kN		
Nb,Rd = 2505.53 kN	My,c,Rd = 508.92 kN*m	Mz,c,Rd = 207.89 kN*m	Vz,Ed = 6.67 kN
	MN,y,Rd = 508.92 kN*m	MN,z,Rd = 207.89 kN*m	Vz,T,Rd = 712.35 kN
	Mb,Rd = 462.65 kN*m		Tt,Ed = 0.10 kN*m
			Class of section = 1

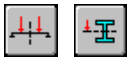

LATERAL BUCKLING PARAMETERS:

z = 0.00	Mcr = 3958.66 kN*m	Curve,LT - b	XLT = 1.00
Lcr,upp=2.75 m	Lam_LT = 0.36	fi,LT = 0.54	XLT,mod = 1.00

BUCKLING PARAMETERS:



About y axis:

Ly = 11.00 m	Lam_y = 0.76
Lcr,y = 9.46 m	Xy = 0.75
Lamy = 65.68	ky = 1.04



About z axis:

Lz = 11.00 m	Lam_z = 0.42
Lcr,z = 2.75 m	Xz = 0.88
Lamz = 36.84	kyz = 0.67

Torsional buckling:

Curve,T=c	alfa,T=0.49
Lt=2.75 m	fi,T=0.63
Ncr,T=22800.09 kN	X,T=0.90
Lam_T=0.40	Nb,T,Rd=2992.03 kN

Flexural-torsional buckling

Curve,TF=c	alfa,TF=0.49
Ncr,y=6413.70 kN	fi,TF=0.92
Ncr,TF=6413.70 kN	X,TF=0.69
Lam_TF=0.76	Nb,TF,Rd=2300.62 kN

VERIFICATION FORMULAS:

Section strength check:

$N_{Ed}/N_{c,Rd} = 0.09 < 1.00$ (6.2.4.(1))
$M_{y,Ed}/M_{N,y,Rd} = 0.41 < 1.00$ (6.2.9.1.(2))
$M_{z,Ed}/M_{N,z,Rd} = 0.04 < 1.00$ (6.2.9.1.(2))
$(M_{y,Ed}/M_{N,y,Rd})^2 + (M_{z,Ed}/M_{N,z,Rd})^1 = 0.21 < 1.00$ (6.2.9.1.(6))
$V_{y,Ed}/V_{y,T,Rd} = 0.00 < 1.00$ (6.2.6-7)
$V_{z,Ed}/V_{z,T,Rd} = 0.01 < 1.00$ (6.2.6-7)
$\tau_{t,y,Ed}/(f_y/(\sqrt{3})gM0) = 0.01 < 1.00$ (6.2.6)

$$\tau_{t,z}, E_d / (f_y / (\sqrt{3}) * gM_0) = 0.00 < 1.00 \quad (6.2.6)$$

Global stability check of member:

$$\lambda_{y}, E_d = 65.68 < \lambda_{y, \max} = 210.00 \quad \lambda_{z}, E_d = 36.84 < \lambda_{z, \max} = 210.00 \quad \text{STABLE}$$

$$N_{Ed} / \min(N_{b,Rd}, T_{b,Rd}, T_{F,Rd}) = 0.15 < 1.00 \quad (6.3.1)$$

$$M_{y,Ed, \max} / M_{b,Rd} = 0.45 < 1.00 \quad (6.3.2.1.(1))$$

$$N_{Ed} / (X_y * N_{Rk} / gM_1) + k_{yy} * M_{y,Ed, \max} / (X_{LT} * M_{y,Rk} / gM_1) + k_{yz} * M_{z,Ed, \max} / (M_{z,Rk} / gM_1) = 0.64 < 1.00 \quad (6.3.3.(4))$$

$$N_{Ed} / (X_z * N_{Rk} / gM_1) + k_{zy} * M_{y,Ed, \max} / (X_{LT} * M_{y,Rk} / gM_1) + k_{zz} * M_{z,Ed, \max} / (M_{z,Rk} / gM_1) = 0.42 < 1.00 \quad (6.3.3.(4))$$

LIMIT DISPLACEMENTS**Deflections (LOCAL SYSTEM):**

$$u_y = 2 \text{ mm} < u_{y, \max} = L / 200.00 = 55 \text{ mm} \quad \text{Verified}$$

$$\text{Governing Load Case: } 469 \text{ COMB450 } (1+2+6+17) * 1.00 + 4 * 0.50$$

$$u_z = 28 \text{ mm} < u_{z, \max} = L / 200.00 = 55 \text{ mm} \quad \text{Verified}$$

$$\text{Governing Load Case: } 475 \text{ COMB456 } (1+2+7+11) * 1.00 + 4 * 0.50$$

$$u_{\text{inst}, y} = 2 \text{ mm} < u_{\text{inst}, \max, y} = L / 250.00 = 44 \text{ mm} \quad \text{Verified}$$

$$\text{Governing Load Case: } 0.5 * 4 + 1 * 6 + 1 * 17$$

$$u_{\text{inst}, z} = 18 \text{ mm} < u_{\text{inst}, \max, z} = L / 250.00 = 44 \text{ mm} \quad \text{Verified}$$

$$\text{Governing Load Case: } 0.5 * 4 + 1 * 7 + 1 * 11$$

**Displacements (GLOBAL SYSTEM):**

$$v_x = 41 \text{ mm} < v_{x, \max} = L / 150.00 = 73 \text{ mm} \quad \text{Verified}$$

$$\text{Governing Load Case: } 461 \text{ COMB442 } (1+2+6+9) * 1.00 + 4 * 0.50$$

$$v_y = 8 \text{ mm} < v_{y, \max} = L / 150.00 = 73 \text{ mm} \quad \text{Verified}$$

$$\text{Governing Load Case: } 437 \text{ COMB418 } (1+2+8+9) * 1.00 + 3 * 0.50$$

Section OK !!!

STUP

Profil	HEA340 , S275
Visina stupa	11 m
$N_{c,Ed}$	346,54 kN
$V_{z,Ed}$	6,67 kN
$M_{y,Ed}$	209,82 kNm
$M_{z,Ed}$	9,05 kNm

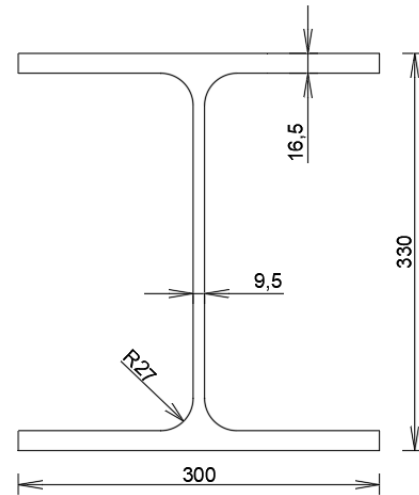

U Tablici 21. dane su karakteristike profila HEA 340.

Tablica 21. Karakteristike profile HEA 340 [izradio autor]

Profil	G	A	h	b	tw	tf	r	I_t	$I_w^* \cdot 10^{-3}$
	kg/m	cm ²	mm	mm	mm	mm	mm	cm ⁴	cm ⁶
HEA340	105	133,5	330	300	9,5	16,5	27	127,2	1824

I_y	W_y	W_{ply}	i_y	$A_{v,z}$	I_z	W_z	$W_{pl,z}$	i_z	$A_{v,y}$
cm ⁴	cm ³	cm ³	cm	cm ²	cm ⁴	cm ³	cm ³	cm	cm ²
27690	1678	1850	14,4	44,95	7436	495,7	755,9	7,46	102,5

Materijal – čelik kvalitete S275

1. Klasifikacija poprečnog presjeka

HRBAT

- Uvjet za klasu 1:

$$\frac{c}{t} = \frac{h - 2 \cdot t_f - 2 \cdot r}{t_w} = \frac{330 - 2 \cdot 16,5 - 2 \cdot 27}{9,5} = 25,58$$

$$a = \frac{N_{Ed}}{2 \cdot t_w \cdot \frac{f_y}{\gamma_{M0}}} = \frac{346,54}{2 \cdot 0,95 \cdot \frac{27,5}{1}} = 6,63 \text{ cm}$$

$$\alpha = \frac{1}{d} \cdot \left(\frac{d}{2} + a \right) = 0,77; \alpha > 0,5$$

$$d = h - 2 \cdot t_f - 2 \cdot r = 330 - 2 \cdot 16,5 - 2 \cdot 27 = 24,3 \text{ cm}$$

$$\frac{c}{t} \leq \frac{396\varepsilon}{13\alpha-1} ; 25,58 < 43,95$$

Hrpat je **klasa 1**.

POJASNICA

- Uvjet za klasu 1:

$$\frac{c}{t} = \frac{\frac{b}{2} - \frac{t_w}{2} - r}{t_f} = 7,17$$

$$\frac{c}{t} \leq 9\varepsilon ; 7,17 < 8,28$$

Pojasnica je **klasa 1**.

➔ Poprečni presjek je **KLASA 1**.

2.1. Otpornost poprečnog presjeka na tlačnu silu

Proračunska tlačna sila $N_{c,Ed} = 346,54 \text{ kN}$

$$N_{c,Rd} = \frac{A \cdot f_y}{\gamma_{MO}} = \frac{133,5 \cdot 27,5}{1} = 3671,25 \text{ kN}$$

Uvjet nosivosti: $N_{Ed} \leq N_{c,Rd} ; 346,54 \text{ kN} < 3671,25 \text{ kN}$ **ZADOVOLJAVA (10%)**

2.2. Otpornost poprečnog presjeka na savijanje

Proračunski moment savijanja $M_{y,Ed} = 209,82 \text{ kNm}$

$$\text{Proračunska nosivost moment savijanja} \quad M_{c,Rd} = \frac{W_{pl,y} \cdot f_y}{\gamma_{MO}} = \frac{1850 \cdot 27,5}{1} = 508,75 \text{ kNm}$$

Uvjet nosivosti: $M_{y,Ed} \leq M_{c,Rd} ; 209,82 \text{ kNm} < 508,75 \text{ kNm}$ **ZADOVOLJAVA (41%)**

2.3. Otpornost poprečnog presjeka na posmik

Proračunska poprečna sila $V_{z,Ed} = 6,67 \text{ kN}$

Provjera izbočivanja hrpta na posmik

$$\frac{h_w}{t_w} \leq 72 \frac{\varepsilon}{\eta}$$

$$\frac{h_w}{t_w} = \frac{h-2 t_f}{t_w} = \frac{330-2 \cdot 16,5}{9,5} = 31,26$$

$$72 \cdot \frac{0,92}{1,2} = 55,2$$

31,26 < 55,2 Nije potrebna provjera izbočivanja hrpta na posmik.

Posmična otpornosti

$$A_{v,z} = 44,95 \text{ cm}^2$$

$$V_{pl,Rd} = \frac{A_{v,z} \cdot f_y}{\gamma_{M0} \sqrt{3}} = \frac{44,95 \cdot 27,5/\sqrt{3}}{1,0} = 713,68 \text{ kN}$$

Uvjet nosivosti: $V_{z,Ed} \leq V_{pl,Rd}$; 6,67 kNm < 713,68 kNm **ZADOVOLJAVA** (1%)

2.4. Interakcija M – N

Uvjet nereducirane plastične otpornosti na savijanje

$$N_{Ed} \leq 0,25 N_{c,Rd}$$

346,54 kN < 0,25 · 3671,25 = 917,81 kN **ZADOVOLJAVA** (10%)

$$N_{Ed} \leq \frac{0,5 \cdot h_w \cdot t_w \cdot f_y}{\gamma_{M0}} = \frac{0,5 \cdot (33-2 \cdot 1,65) \cdot 0,95 \cdot 27,5}{1} ; 346,54 < 387,96 \quad \mathbf{ZADOVOLJAVA} \text{ (89\%)}$$

Niska razina uzdužne sile – nema utjecaj na otpornost presjeka na savijanje

$$M_{V,N,y,Rd} = M_{pl,y,Rd}$$

Uvjet nosivosti: $M_{y,Ed} \leq M_{V,N,y,Rd}$ 209,82 kNm < 508,75 kNm **ZADOVOLJAVA** (41%)

2.5. Interakcija M – V

Uvjet nereducirane plastične otpornosti na savijanje

$V_{z,Ed} \leq 0,5 V_{pl,Rd}$; 6,67 kNm < 356,84 kNm → Nije potrebna redukcija plastične otpornosti na savijanje.

$$M_{y,V,Ed} = M_{pl,y,Rd}$$

Uvjet nosivosti: $M_{y,Ed} \leq M_{y,V,Rd}$; 209,82 kNm < 508,75 kNm **ZADOVOLJAVA** (41%)

3.1. Otpornost elementa na izvijanje

$$N_{b,Rd} = \chi \frac{A \cdot f_y}{\gamma_{M1}}$$

Oko osi y

$$N_{cr} = \frac{\pi^2 \cdot E \cdot I}{l_{cr}^2} = \frac{\pi^2 \cdot 21000 \cdot 27690}{1100^2} = 4743,04 \text{ kN}$$

$$\lambda = \sqrt{\frac{A \cdot f_y}{N_{cr}}} = \sqrt{\frac{133,5 \cdot 27,5}{4743,04}} = 0,88$$

Određivanje mjerodavne linije izvijanja:

$$h/b = 330/300 = 1,1 < 1,2$$

Os y - y → krivulja izvijanja b

Koeficijent nesavršenosti $\alpha = 0,34$

$$\Phi = 0,5 * [1 + \alpha * (\lambda - 0,2) + \lambda^2] = 0,5 * [1 + 0,34 * (0,88 - 0,2) + 0,88^2] = 1,00$$

$$\chi = \frac{1}{\Phi + \sqrt{\Phi^2 - \lambda^2}} = \frac{1}{1 + \sqrt{1^2 - 0,88^2}} = 0,68$$

Oko osi z

$$N_{cr} = \frac{\pi^2 \cdot E \cdot I}{l_{cr}^2} = \frac{\pi^2 \cdot 21000 \cdot 7436}{550^2} = 5094,87 \text{ kN}$$

$$\lambda = \sqrt{\frac{A \cdot f_y}{N_{cr}}} = \sqrt{\frac{133,5 \cdot 27,5}{5094,87}} = 0,85$$

$$h/b = 330/300 = 1,1 < 1,2$$

Os z - z → krivulja izvijanja c

Koeficijent nesavršenosti $\alpha = 0,49$

$$\Phi = 0,5 * [1 + \alpha * (\lambda - 0,2) + \lambda^2] = 0,5 * [1 + 0,49 * (0,85 - 0,2) + 0,85^2] = 1$$

$$\chi = \frac{1}{\Phi + \sqrt{\Phi^2 - \lambda^2}} = \frac{1}{1 + \sqrt{1^2 - 0,85^2}} = 0,65$$

$$N_{b,Rd} = \chi \cdot \frac{A \cdot f_y}{\gamma_{M1}} = 0,68 \cdot \frac{133,5 \cdot 27,5}{1} = 2496,45 \text{ kN}$$

Uvjet nosivosti: $N_{c,Ed} \leq N_{b,Rd}$; $346,54 \text{ kN} < 2496,45 \text{ kN}$ **ZADOVOLJAVA**

3.2. Otpornost elementa na bočno torzijsko izvijanje

$$L_{cr} = 275 \text{ cm}$$

$$M_{cr} = C_1 \cdot \frac{\pi^2 \cdot E \cdot I_z}{(k \cdot L_{cr})^2} \cdot \left[\sqrt{\left(\frac{k}{k_w}\right)^2 \cdot \frac{I_w}{I_z} + \frac{(k \cdot L_{cr})^2 \cdot G \cdot I_t}{\pi^2 \cdot E \cdot I_z}} \right]$$

$$= 1,77 \cdot \frac{\pi^2 \cdot 21000 \cdot 7436}{(1 \cdot 275)^2} * \left[\sqrt{(1)^2 \cdot \frac{1824000}{7436} + \frac{(1 \cdot 275)^2 \cdot 8077 \cdot 127,2}{\pi^2 \cdot 21000 \cdot 7436}} \right]$$

$$M_{cr} = 620292,64 \text{ kNcm}$$

Bezdimenzionalna bočna torzijska vitkost (svedena vitkost):

$$\bar{\lambda}_{LT} = \sqrt{\frac{W_{pl,y} \cdot f_y}{M_{cr}}} = \sqrt{\frac{1850 \cdot 27,5}{190648,68}} = 0,29 < 0,4 \quad \text{- radi se o zdepastom nosaču, B-T ne utječe}$$

na otpornost nosača. Do otkazivanja dolazi doseganjem pune plastične otpornosti M_{pl} .

$$\chi_{LT} = 1$$

$$M_{b,Rd} = M_{C,Rd} = 508,75 \text{ kNm}$$

Uvjet nosivosti: $M_{y,Ed} \leq M_{b,Rd}$; $209,82 \text{ kNm} < 508,75 \text{ kNm}$ **ZADOVOLJAVA**

3.3. Interakcija izvijanja i bočno-torzijskog izvijanja (N – M)

Proračunski moment savijanja i proračunska uzdužna sila:

$$N_{c,Ed} = 346,54 \text{ kN}$$

$$M_{y,Ed} = 209,82 \text{ kNm}$$

Uvjeti koji moraju biti zadovoljeni:

$$\frac{N_{Ed}}{\chi_y \cdot \frac{N_{Rk}}{\gamma_{M1}}} + k_{yy} \cdot \frac{M_{y,Ed}}{\chi_{LT} \cdot \frac{M_{y,Rk}}{\gamma_{M1}}} \leq 1$$

$$\frac{N_{Ed}}{\chi_z \cdot \frac{N_{Rk}}{\gamma_{M1}}} + k_{zy} \cdot \frac{M_{y,Ed}}{\chi_{LT} \cdot \frac{M_{y,Rk}}{\gamma_{M1}}} \leq 1$$

Karakteristične vrijednosti nosivosti na tlak i moment savijanja:

$$N_{Rk} = A \cdot f_y = 133,5 \cdot 27,5 = 3671,25 \text{ kN}$$

$$M_{y,Rk} = W_{pl,y} \cdot f_y = 1850 \cdot 27,5 = 50875 \text{ kNcm} = 508,75 \text{ kNm}$$

Potrebni podaci za proračun interakcije:

$$\lambda_y = 0,88$$

$$\lambda_z = 0,85$$

$$\phi_y = 1$$

$$\phi_z = 1$$

$$\chi_y = 0,68$$

$$\chi_z = 0,65$$

Koeficijent C_{my} :

$$C_{my} = 0.6 + 0.4 \cdot \psi = 0.6$$

$$k_{yy} = C_{my} \cdot \left[1 + (\bar{\lambda}_y - 0.2) \cdot \frac{N_{Ed}}{\phi_y \cdot \frac{N_{Rk}}{\gamma_{M1}}} \right] \leq C_{my} \cdot \left(1 + 0.8 \cdot \frac{N_{Ed}}{\chi_y \cdot \frac{N_{Rk}}{\gamma_{M1}}} \right)$$

$$k_{yy} = 0.60 \cdot \left[1 + (0.88 - 0.2) \cdot \frac{346,54}{1 \cdot \frac{3671,25}{1,1}} \right] \leq 0.60 \cdot \left(1 + 0.8 \cdot \frac{346,54}{0,68 \cdot \frac{3671,25}{1,1}} \right)$$

$$k_{yy} = 0,642 < 0,673$$

Koeficijent interakcije k_{zy} :

$$k_{zy} = 0,60 \cdot k_{yy}$$

$$k_{zy} = 0,60 \cdot 0,642 = 0,385$$

Uvjeti interakcije:

$$\frac{N_{Ed}}{\chi_y \frac{N_{RK}}{\gamma_{M1}}} + k_{yy} \cdot \frac{M_{y,Ed}}{\chi_{LT} \frac{M_{y,Rk}}{\gamma_{M1}}} = \frac{346,54}{0,68 \cdot \frac{3671,25}{1,1}} + 0,642 \cdot \frac{209,82}{0,92 \cdot \frac{508,75}{1,1}} = 0,57 < 1 \quad \text{ZADOVOLJAVA}$$

$$\frac{N_{Ed}}{\chi_z \frac{N_{RK}}{\gamma_{M1}}} + k_{zy} \cdot \frac{M_{y,Ed}}{\chi_{LT} \frac{M_{y,Rk}}{\gamma_{M1}}} = \frac{346,54}{0,65 \cdot \frac{3671,25}{1,1}} + 0,385 \cdot \frac{209,82}{0,92 \cdot \frac{508,75}{1,1}} = 0,38 < 1 \quad \text{ZADOVOLJAVA}$$

7.2. Vanjski zabatni stupovi

Na Slici 40. prikazan je položaj mjerodavnog vanjskog zabatnog stupa za dimenzioniranje, te vrijednosti na dijagramima za karakterističnu kombinaciju 223 (COMB203)

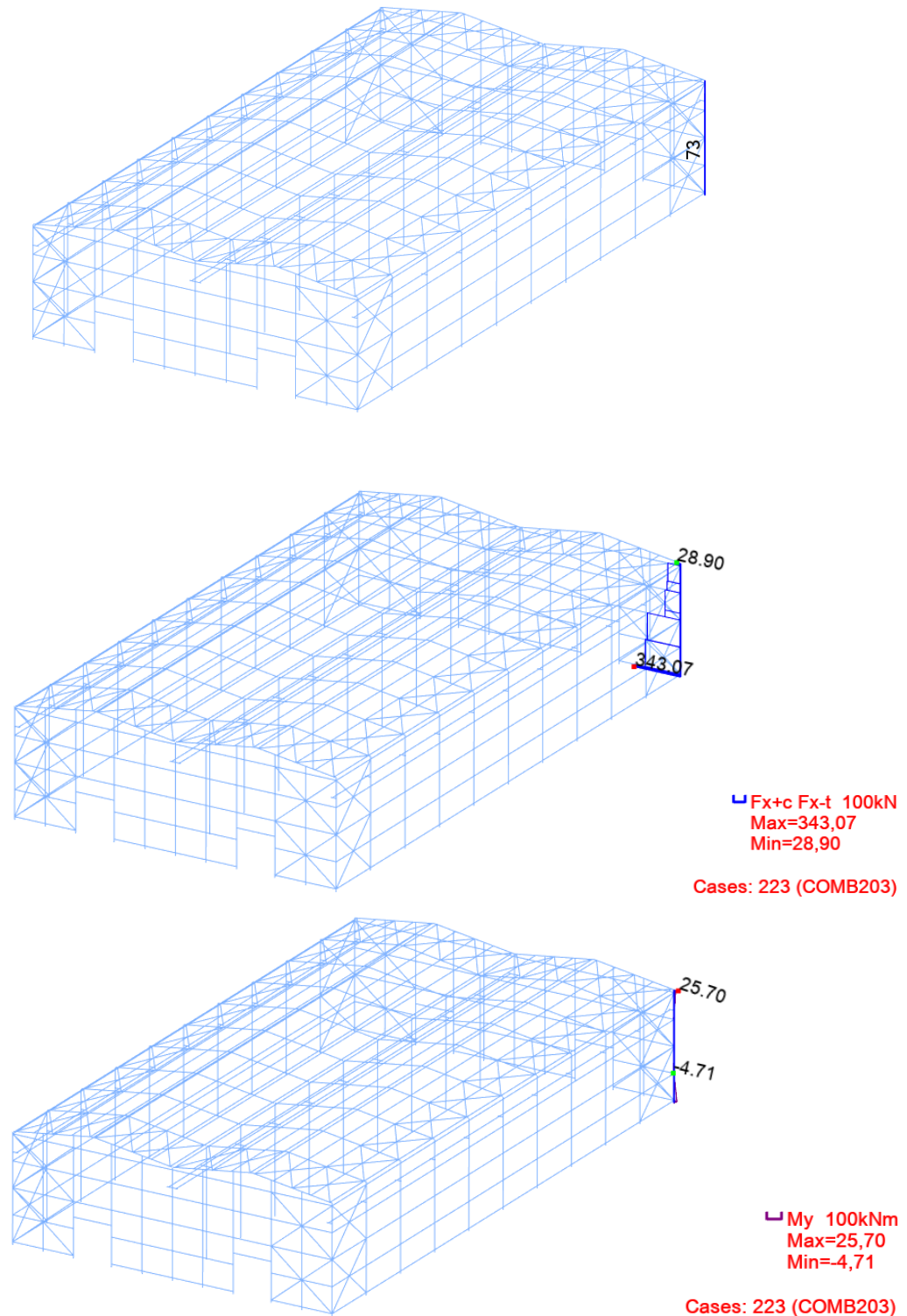

Slika 40. Položaj i vrijednosti dijagrama na vanjskom zabatnom stupu mjerodavnom za dimenzioniranje [izradio autor]

STEEL DESIGN

CODE: EN 1993-1:2005/A1:2014, Eurocode 3: Design of steel structures.

ANALYSIS TYPE: Member Verification

CODE GROUP:

MEMBER: 73

POINT: 3

COORDINATE: $x = 0.02 L = 0.25$

m

LOADS:

Governing Load Case: 223 COMB203 (1+2)*1.35+(6+9)*1.50+4*0.75

MATERIAL:

S 355 (S 355) $f_y = 355.00$ MPa



SECTION PARAMETERS: IPE 330

h=330 mm	gM0=1.00	gM1=1.10	
b=160 mm	Ay=4228 mm ²	Az=3081 mm ²	Ax=6261 mm ²
tw=8 mm	Iy=117669000 mm ⁴	Iz=7881430 mm ⁴	Ix=257000 mm ⁴
tf=12 mm	Wply=804399 mm ³	Wplz=153683 mm ³	

INTERNAL FORCES AND CAPACITIES:

N,Ed = 342.90 kN	My,Ed = 20.59 kN*m	Mz,Ed = 3.79 kN*m	Vy,Ed = -15.18 kN
Nc,Rd = 2222.52 kN	My,Ed,max = 20.59 kN*m	Mz,Ed,max = 3.79 kN*m	Vy,c,Rd = 866.59 kN
Nb,Rd = 1187.90 kN	My,c,Rd = 285.56 kN*m	Mz,c,Rd = 54.56 kN*m	Vz,Ed = 82.36 kN
	MN,y,Rd = 285.56 kN*m	MN,z,Rd = 54.56 kN*m	Vz,c,Rd = 631.45 kN
	Mb,Rd = 206.02 kN*m		

Class of section = 1

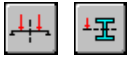

LATERAL BUCKLING PARAMETERS:

z = 0.00	Mcr = 457.25 kN*m	Curve,LT - c	XLT = 0.77
Lcr,upp=2.75 m	Lam_LT = 0.79	fi,LT = 0.83	XLT,mod = 0.79

BUCKLING PARAMETERS:



About y axis:

Ly = 11.00 m	Lam_y = 0.26
Lcr,y = 2.75 m	Xy = 0.99
Lamy = 20.06	kzy = 0.63

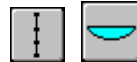

About z axis:

Lz = 11.00 m	Lam_z = 1.01
Lcr,z = 2.75 m	Xz = 0.59
Lamz = 77.51	kzz = 1.14

Torsional buckling:

Curve,T=b	alfa,T=0.34
Lt=2.75 m	fi,T=0.89
Ncr,T=3766.69 kN	X,T=0.74
Lam_T=0.77	Nb,T,Rd=1503.01 kN

Flexural-torsional buckling

Curve,TF=b	alfa,TF=0.34
Ncr,y=32248.96 kN	fi,TF=0.55
Ncr,TF=32248.96 kN	X,TF=0.98
Lam_TF=0.26	Nb,TF,Rd=1975.45 kN

VERIFICATION FORMULAS:

Section strength check:

$N_{Ed}/N_{c,Rd} = 0.15 < 1.00$ (6.2.4.(1))
$M_{y,Ed}/M_{N,y,Rd} = 0.07 < 1.00$ (6.2.9.1.(2))
$M_{z,Ed}/M_{N,z,Rd} = 0.07 < 1.00$ (6.2.9.1.(2))
$(M_{y,Ed}/M_{N,y,Rd})^2 + (M_{z,Ed}/M_{N,z,Rd})^1 = 0.07 < 1.00$ (6.2.9.1.(6))
$V_{y,Ed}/V_{y,c,Rd} = 0.02 < 1.00$ (6.2.6.(1))
$V_{z,Ed}/V_{z,c,Rd} = 0.13 < 1.00$ (6.2.6.(1))

Global stability check of member:

$\Lambda_{b,y} = 20.06 < \Lambda_{b,max} = 210.00$	$\Lambda_{b,z} = 77.51 < \Lambda_{b,max} = 210.00$	STABLE
--	--	--------

$$N_{Ed}/\text{Min}(N_b, R_d, N_b, T, R_d, N_b, T, F, R_d) = 0.29 < 1.00 \quad (6.3.1)$$

$$M_{y,Ed,max}/M_b, R_d = 0.10 < 1.00 \quad (6.3.2.1.(1))$$

$$N_{Ed}/(X_y * N_{Rk}/gM1) + k_{yy} * M_{y,Ed,max}/(X_{LT} * M_{y,Rk}/gM1) + k_{yz} * M_{z,Ed,max}/(M_{z,Rk}/gM1) = 0.36 < 1.00 \quad (6.3.3.(4))$$

$$N_{Ed}/(X_z * N_{Rk}/gM1) + k_{zy} * M_{y,Ed,max}/(X_{LT} * M_{y,Rk}/gM1) + k_{zz} * M_{z,Ed,max}/(M_{z,Rk}/gM1) = 0.44 < 1.00 \quad (6.3.3.(4))$$

LIMIT DISPLACEMENTS



Deflections (LOCAL SYSTEM):

$$u_y = 1 \text{ mm} < u_y \text{ max} = L/200.00 = 55 \text{ mm} \quad \text{Verified}$$

$$\text{Governing Load Case: } 276 \text{ COMB256 } (1+2+6)*1.00+4*0.50$$

$$u_z = 0 \text{ mm} < u_z \text{ max} = L/200.00 = 55 \text{ mm} \quad \text{Verified}$$

$$\text{Governing Load Case: } 5 \text{ Vjetar 1}$$

$$u_{\text{inst},y} = 1 \text{ mm} < u_{\text{inst,max},y} = L/200.00 = 55 \text{ mm} \quad \text{Verified}$$

$$\text{Governing Load Case: } 0.5*3 + 1*7 + 1*17$$

$$u_{\text{inst},z} = 0 \text{ mm} < u_{\text{inst,max},z} = L/200.00 = 55 \text{ mm} \quad \text{Verified}$$

$$\text{Governing Load Case: } 1*5$$



Displacements (GLOBAL SYSTEM):

$$v_x = 13 \text{ mm} < v_x \text{ max} = L/150.00 = 73 \text{ mm} \quad \text{Verified}$$

$$\text{Governing Load Case: } 461 \text{ COMB442 } (1+2+6+9)*1.00+4*0.50$$

$$v_y = 9 \text{ mm} < v_y \text{ max} = L/150.00 = 73 \text{ mm} \quad \text{Verified}$$

$$\text{Governing Load Case: } 473 \text{ COMB454 } (1+2+7+9)*1.00+4*0.50$$

Section OK !!!

7.3. Unutarnji stupovi

Na Slici 41. prikazan je položaj mjerodavnog unutarnjeg stupa za dimenzioniranje, te vrijednosti na dijagramima za karakterističnu kombinaciju 142 (COMB122)

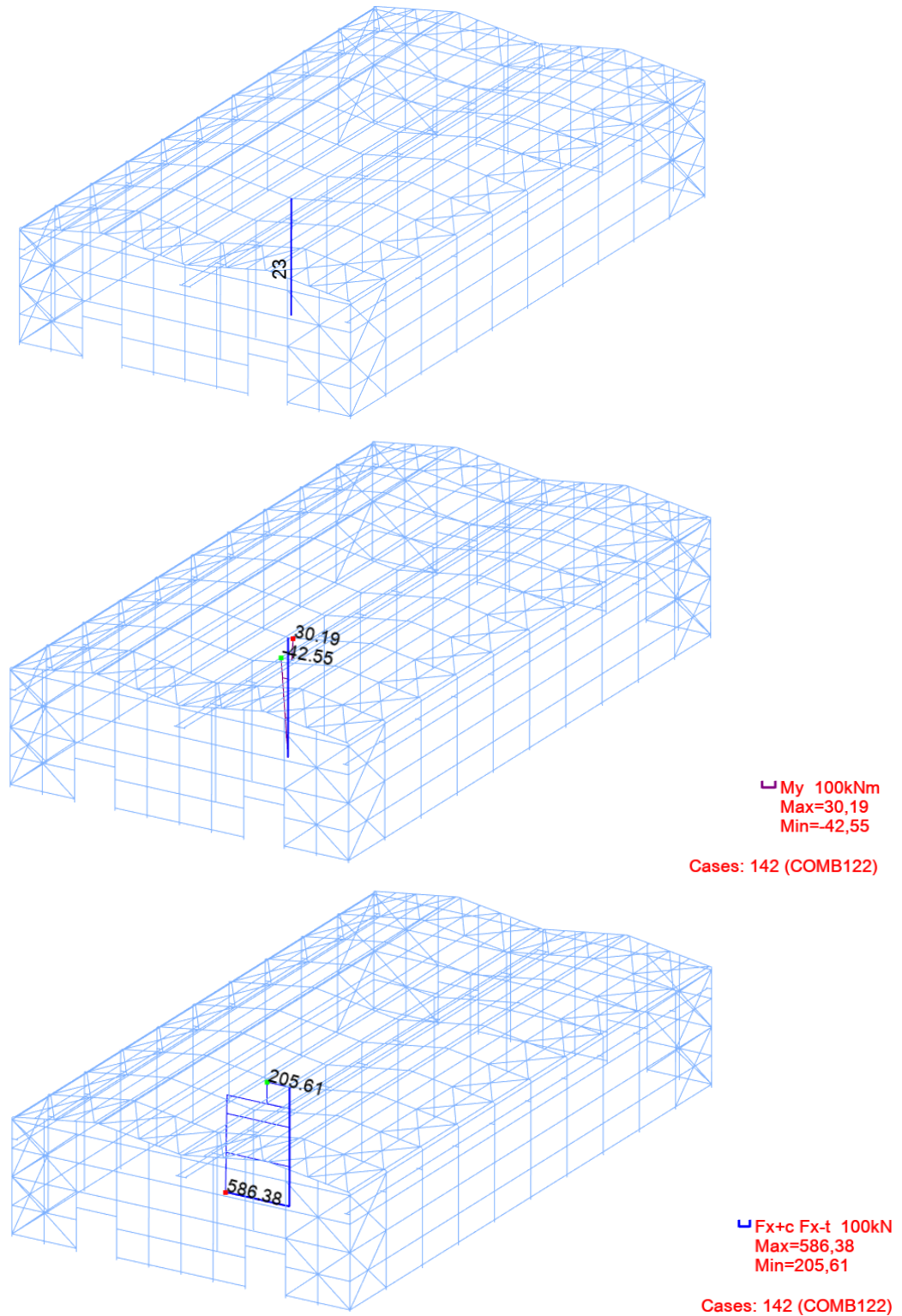

Slika 41. Položaj i vrijednosti dijagrama na unutarnjem stupu mjerodavnom za dimenzioniranje [izradio autor]

STEEL DESIGN

CODE: EN 1993-1:2005/A1:2014, Eurocode 3: Design of steel structures.

ANALYSIS TYPE: Member Verification

CODE GROUP:

MEMBER: 23

POINT: 3

COORDINATE: x = 0.82 L = 9.00

m

LOADS:

Governing Load Case: 142 COMB122 (1+2)*1.35+(4+12)*1.50+7*0.90

MATERIAL:

S 275 (S 275) $f_y = 275.00$ MPa



SECTION PARAMETERS: HEA 340

h=330 mm	gM0=1.00	gM1=1.10	
b=300 mm	Ay=11039 mm ²	Az=4495 mm ²	Ax=13347 mm ²
tw=10 mm	Iy=276931000 mm ⁴	Iz=74360000 mm ⁴	Ix=1230000 mm ⁴
tf=17 mm	Wply=1850620 mm ³	Wplz=755963 mm ³	

INTERNAL FORCES AND CAPACITIES:

N,Ed = 573.89 kN	My,Ed = -42.55 kN*m	Mz,Ed = 13.62 kN*m	Vy,Ed = -1.51 kN
Nc,Rd = 3670.51 kN	My,Ed,max = -42.55 kN*m	Mz,Ed,max = 13.62 kN*m	Vy,c,Rd = 1752.64 kN
Nb,Rd = 861.98 kN	My,c,Rd = 508.92 kN*m	Mz,c,Rd = 207.89 kN*m	Vz,Ed = -4.73 kN
	MN,y,Rd = 493.02 kN*m	MN,z,Rd = 207.89 kN*m	Vz,c,Rd = 713.69 kN
			Class of section = 1



LATERAL BUCKLING PARAMETERS:

BUCKLING PARAMETERS:



About y axis:

Ly = 11.00 m	Lam_y = 0.88
Lcr,y = 11.00 m	Xy = 0.67
Lamy = 76.37	kzy = 0.58



About z axis:

Lz = 11.00 m	Lam_z = 1.70
Lcr,z = 11.00 m	Xz = 0.26
Lamz = 147.37	kzz = 1.50

VERIFICATION FORMULAS:

Section strength check:

$$N_{Ed}/N_{c,Rd} = 0.16 < 1.00 \quad (6.2.4.(1))$$

$$M_{y,Ed}/M_{N,y,Rd} = 0.09 < 1.00 \quad (6.2.9.1.(2))$$

$$M_{z,Ed}/M_{N,z,Rd} = 0.07 < 1.00 \quad (6.2.9.1.(2))$$

$$(M_{y,Ed}/M_{N,y,Rd})^{2.00} + (M_{z,Ed}/M_{N,z,Rd})^{1.00} = 0.07 < 1.00 \quad (6.2.9.1.(6))$$

$$V_{y,Ed}/V_{y,c,Rd} = 0.00 < 1.00 \quad (6.2.6.(1))$$

$$V_{z,Ed}/V_{z,c,Rd} = 0.01 < 1.00 \quad (6.2.6.(1))$$

Global stability check of member:

$$\lambda_{y} = 76.37 < \lambda_{y,max} = 210.00 \quad \lambda_{z} = 147.37 < \lambda_{z,max} = 210.00 \quad \text{STABLE}$$

$$N_{Ed}/(X_y \cdot N_{Rk}/gM1) + k_{yy} \cdot M_{y,Ed,max}/(XLT \cdot M_{y,Rk}/gM1) + k_{yz} \cdot M_{z,Ed,max}/(M_{z,Rk}/gM1) = 0.49 < 1.00 \quad (6.3.3.(4))$$

$$N_{Ed}/(X_z \cdot N_{Rk}/gM1) + k_{zy} \cdot M_{y,Ed,max}/(XLT \cdot M_{y,Rk}/gM1) + k_{zz} \cdot M_{z,Ed,max}/(M_{z,Rk}/gM1) = 0.83 < 1.00 \quad (6.3.3.(4))$$

LIMIT DISPLACEMENTS



Deflections (LOCAL SYSTEM):

uy = 8 mm < uy max = L/200.00 = 55 mm

Verified

Governing Load Case: 492 COMB474 (1+2+8+16)*1.00+4*0.50
uz = 6 mm < uz max = L/200.00 = 55 mm Verified

Governing Load Case: 10 Kran 2
u inst,y = 8 mm < u inst,max,y = L/250.00 = 44 mm Verified

Governing Load Case: 0.5*4 + 1*8 + 1*16
u inst,z = 6 mm < u inst,max,z = L/250.00 = 44 mm Verified

Governing Load Case: 0.5*4 + 1*8 + 1*10



Displacements (GLOBAL SYSTEM):

vx = 33 mm < vx max = L/150.00 = 73 mm Verified

Governing Load Case: 461 COMB442 (1+2+6+9)*1.00+4*0.50
vy = 13 mm < vy max = L/150.00 = 73 mm Verified

Governing Load Case: 444 COMB425 (1+2+8+16)*1.00+3*0.50

Section OK !!!

7.4. Unutarnji zabatni stupovi

Na Slici 42. prikazan je položaj mjerodavnog unutarnjeg zabatnog stupa za dimenzioniranje, te vrijednosti na dijagramima za karakterističnu kombinaciju 218 (COMB198)

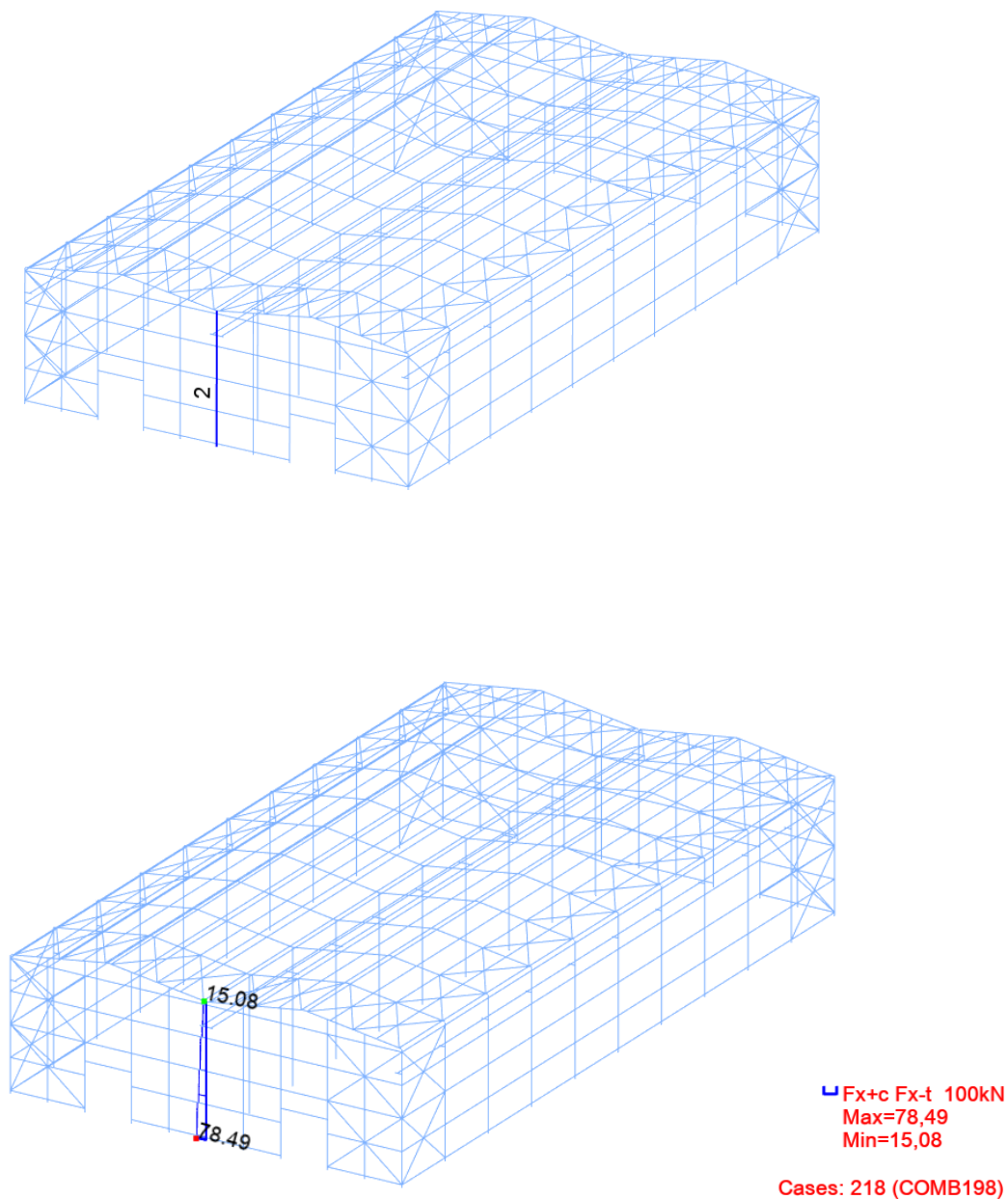

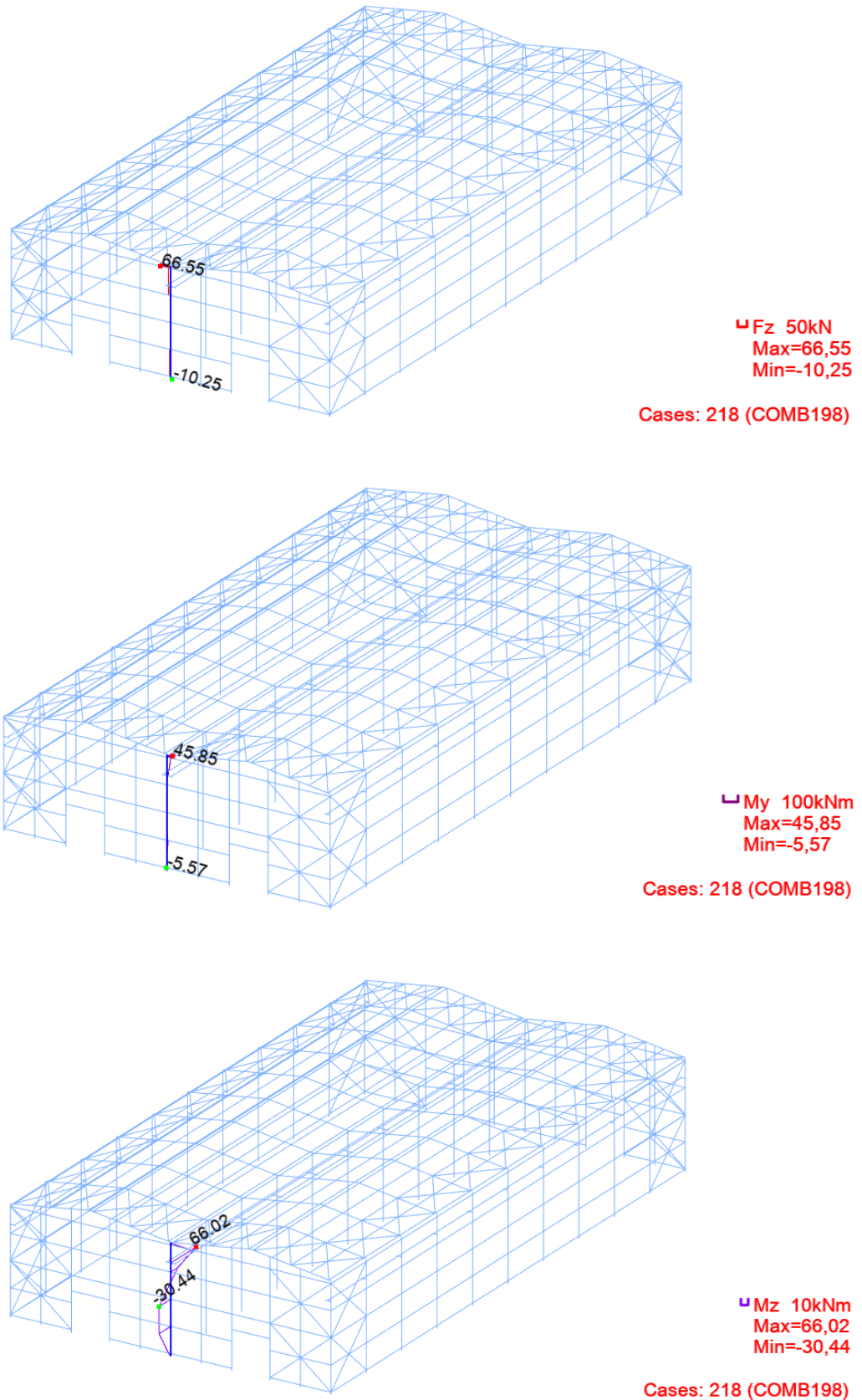

Slika 42. Položaj i vrijednosti dijagrama na zabatnom unut. stupu mjerodavnom za dimenzioniranje [izradio autor]

STEEL DESIGN

CODE: EN 1993-1:2005/A1:2014, Eurocode 3: Design of steel structures.

ANALYSIS TYPE: Member Verification

CODE GROUP:

MEMBER: 2

POINT: 3

COORDINATE: $x = 0.82 L = 9.00$

m

LOADS:

Governing Load Case: 218 COMB198 (1+2)*1.35+(5+16)*1.50+4*0.75

MATERIAL:

S 275 (S 275) $f_y = 275.00$ MPa



SECTION PARAMETERS: HEA 340

h=330 mm	gM0=1.00	gM1=1.10	
b=300 mm	Ay=11039 mm ²	Az=4495 mm ²	Ax=13347 mm ²
tw=10 mm	Iy=276931000 mm ⁴	Iz=74360000 mm ⁴	Ix=1230000 mm ⁴
tf=17 mm	Wply=1850620 mm ³	Wplz=755963 mm ³	

INTERNAL FORCES AND CAPACITIES:

N,Ed = 32.24 kN	My,Ed = 6.35 kN*m	Mz,Ed = 66.02 kN*m	Vy,Ed = -54.04 kN
Nc,Rd = 3670.51 kN	My,Ed,max = 45.85 kN*m	Mz,Ed,max = 66.02 kN*m	Vy,T,Rd = 1747.12 kN
Nb,Rd = 861.98 kN	My,c,Rd = 508.92 kN*m	Mz,c,Rd = 207.89 kN*m	Vz,Ed = 12.50 kN
	MN,y,Rd = 508.92 kN*m	MN,z,Rd = 207.89 kN*m	Vz,T,Rd = 712.39 kN
	Mb,Rd = 462.65 kN*m		Tt,Ed = 0.09 kN*m
			Class of section = 1



LATERAL BUCKLING PARAMETERS:

z = 0.00	Mcr = 3958.66 kN*m	Curve,LT - b	XLT = 1.00
Lcr,upp=2.75 m	Lam_LT = 0.36	fi,LT = 0.54	XLT,mod = 1.00

BUCKLING PARAMETERS:



About y axis:

Ly = 11.00 m	Lam_y = 0.88
Lcr,y = 11.00 m	Xy = 0.67
Lamy = 76.37	kzy = 0.52



About z axis:

Lz = 11.00 m	Lam_z = 1.70
Lcr,z = 11.00 m	Xz = 0.26
Lamz = 147.37	kzz = 1.02

VERIFICATION FORMULAS:

Section strength check:

$$N_{Ed}/N_{c,Rd} = 0.01 < 1.00 \quad (6.2.4.(1))$$

$$M_{y,Ed}/M_{N,y,Rd} = 0.01 < 1.00 \quad (6.2.9.1.(2))$$

$$M_{z,Ed}/M_{N,z,Rd} = 0.32 < 1.00 \quad (6.2.9.1.(2))$$

$$(M_{y,Ed}/M_{N,y,Rd})^{2.00} + (M_{z,Ed}/M_{N,z,Rd})^{1.00} = 0.32 < 1.00 \quad (6.2.9.1.(6))$$

$$V_{y,Ed}/V_{y,T,Rd} = 0.03 < 1.00 \quad (6.2.6-7)$$

$$V_{z,Ed}/V_{z,T,Rd} = 0.02 < 1.00 \quad (6.2.6-7)$$

$$\tau_{t,y,Ed}/(f_y/(\sqrt{3}*gM0)) = 0.01 < 1.00 \quad (6.2.6)$$

$$\tau_{t,z,Ed}/(f_y/(\sqrt{3}*gM0)) = 0.00 < 1.00 \quad (6.2.6)$$

Global stability check of member:

$$\lambda_{da,y} = 76.37 < \lambda_{da,max} = 210.00 \quad \lambda_{da,z} = 147.37 < \lambda_{da,max} = 210.00 \quad \text{STABLE}$$

$$M_{y,Ed,max}/M_{b,Rd} = 0.10 < 1.00 \quad (6.3.2.1.(1))$$

$$N_{Ed}/(X_y*N_{Rk}/gM1) + k_{yy}*M_{y,Ed,max}/(XLT*M_{y,Rk}/gM1) + k_{yz}*M_{z,Ed,max}/(M_{z,Rk}/gM1) = 0.37 < 1.00 \quad (6.3.3.(4))$$

$$N,Ed/(Xz*N,Rk/gM1) + kzy*My,Ed,max/(XLT*My,Rk/gM1) + kzz*Mz,Ed,max/(Mz,Rk/gM1) = 0.45 < 1.00$$

(6.3.3.(4))

LIMIT DISPLACEMENTS
**Deflections (LOCAL SYSTEM):**

$$u_y = 17 \text{ mm} < u_{y \text{ max}} = L/200.00 = 55 \text{ mm} \quad \text{Verified}$$

Governing Load Case: 440 COMB421 (1+2+8+12)*1.00+3*0.50

$$u_z = 0 \text{ mm} < u_{z \text{ max}} = L/200.00 = 55 \text{ mm} \quad \text{Verified}$$

Governing Load Case: 421 COMB402 (1+2+6+17)*1.00+3*0.60

$$u_{\text{inst},y} = 17 \text{ mm} < u_{\text{inst,max},y} = L/250.00 = 44 \text{ mm} \quad \text{Verified}$$

Governing Load Case: 0.5*3 + 1*8 + 1*12

$$u_{\text{inst},z} = 0 \text{ mm} < u_{\text{inst,max},z} = L/250.00 = 44 \text{ mm} \quad \text{Verified}$$

Governing Load Case: 0.6*3 + 1*6 + 1*17

**Displacements (GLOBAL SYSTEM):**

$$v_x = 13 \text{ mm} < v_{x \text{ max}} = L/150.00 = 73 \text{ mm} \quad \text{Verified}$$

Governing Load Case: 465 COMB446 (1+2+6+13)*1.00+4*0.50

$$v_y = 13 \text{ mm} < v_{y \text{ max}} = L/150.00 = 73 \text{ mm} \quad \text{Verified}$$

Governing Load Case: 444 COMB425 (1+2+8+16)*1.00+3*0.50

Section OK !!!

7.5. Gredni nosači

Na Slici 43. prikazan je položaj mjerodavnog grednog nosača za dimenzioniranje, te vrijednosti na dijagramima za karakterističnu kombinaciju 140 (COMB120)

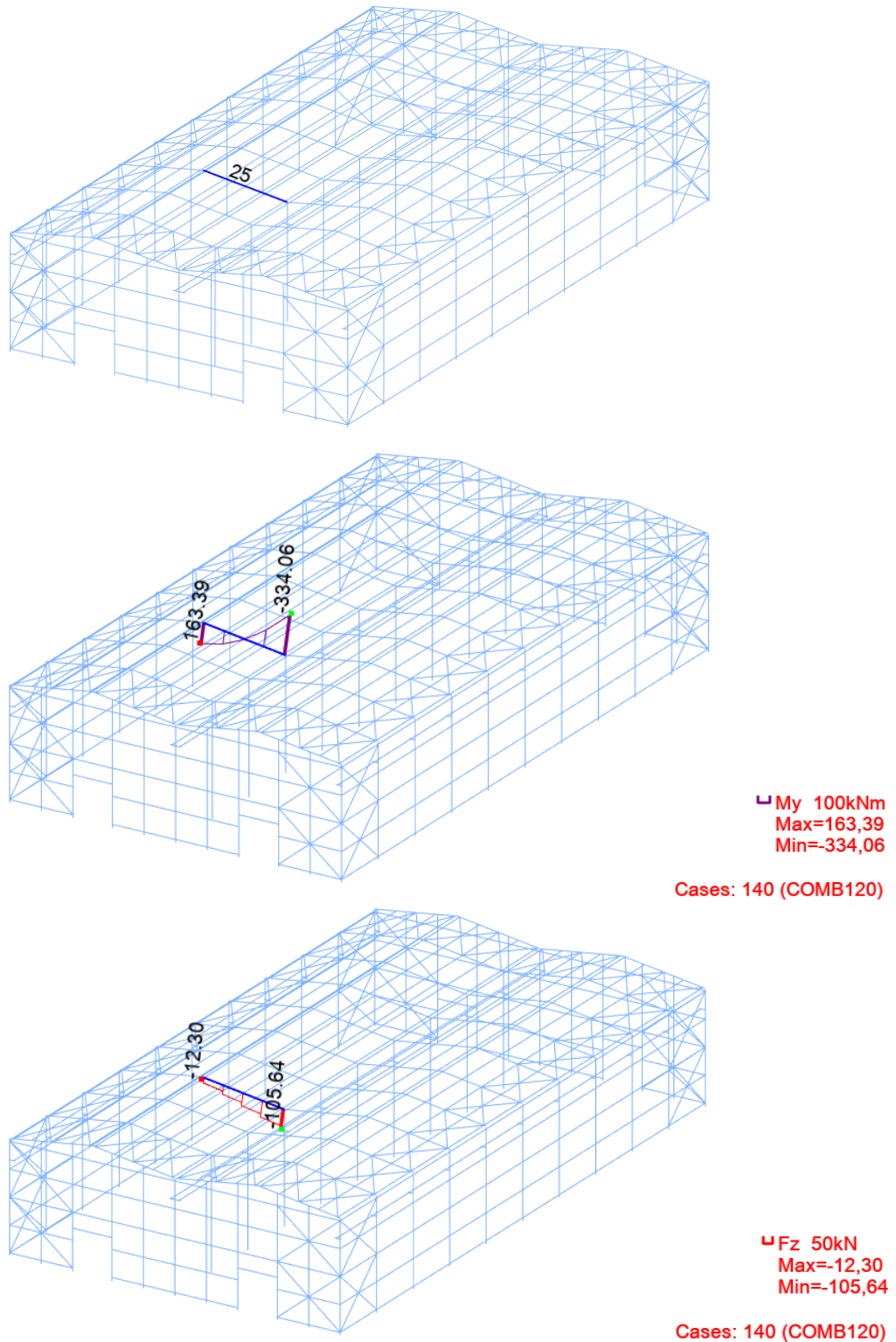

Slika 43. Položaj i vrijednosti dijagrama na grednom nosaču mjerodavnom za dimenzioniranje [izradio autor]

STEEL DESIGN

CODE: EN 1993-1:2005/A1:2014, Eurocode 3: Design of steel structures.

ANALYSIS TYPE: Member Verification

CODE GROUP:

MEMBER: 25

POINT: 3

COORDINATE: $x = 1.00$ $L = 8.49$

m

LOADS:

Governing Load Case: 140 COMB120 (1+2)*1.35+(4+10)*1.50+7*0.90

MATERIAL:

S 275 (S 275) $f_y = 275.00$ MPa

SECTION PARAMETERS: HEA 340

h=330 mm	gM0=1.00	gM1=1.10	
b=300 mm	Ay=11039 mm ²	Az=4495 mm ²	Ax=13347 mm ²
tw=10 mm	Iy=276931000 mm ⁴	Iz=74360000 mm ⁴	Ix=1230000 mm ⁴
tf=17 mm	Wply=1850620 mm ³	Wplz=755963 mm ³	

INTERNAL FORCES AND CAPACITIES:

N,Ed = 20.76 kN	My,Ed = -334.06 kN*m	Mz,Ed = 0.49 kN*m	Vy,Ed = -2.97 kN
Nc,Rd = 3670.51 kN	My,Ed,max = -334.06 kN*m		Mz,Ed,max = 0.49 kN*m
	Vy,T,Rd = 1720.25 kN		
Nb,Rd = 2820.37 kN	My,c,Rd = 508.92 kN*m	Mz,c,Rd = 207.89 kN*m	Vz,Ed = -105.64 kN
	MN,y,Rd = 508.92 kN*m	MN,z,Rd = 207.89 kN*m	Vz,T,Rd = 706.12 kN
	Mb,Rd = 462.65 kN*m		Tt,Ed = -0.54 kN*m
			Class of section = 1



LATERAL BUCKLING PARAMETERS:

z = 0.00	Mcr = 785114.45 kN*m	Curve,LT - b	XLT = 1.00
Lcr,low=0.19 m	Lam_LT = 0.03	fi,LT = 0.44	XLT,mod = 1.00

BUCKLING PARAMETERS:



About y axis:

Ly = 8.49 m	Lam_y = 0.58
Lcr,y = 7.30 m	Xy = 0.85
Lamy = 50.66	kyy = 1.00



About z axis:

Lz = 8.49 m	Lam_z = 0.03
Lcr,z = 0.19 m	Xz = 1.00
Lamz = 2.50	kyz = 0.70

VERIFICATION FORMULAS:

Section strength check:

$$N_{Ed}/N_{c,Rd} = 0.01 < 1.00 \quad (6.2.4.(1))$$

$$M_{y,Ed}/M_{N,y,Rd} = 0.66 < 1.00 \quad (6.2.9.1.(2))$$

$$M_{z,Ed}/M_{N,z,Rd} = 0.00 < 1.00 \quad (6.2.9.1.(2))$$

$$(M_{y,Ed}/M_{N,y,Rd})^{2.00} + (M_{z,Ed}/M_{N,z,Rd})^{1.00} = 0.43 < 1.00 \quad (6.2.9.1.(6))$$

$$V_{y,Ed}/V_{y,T,Rd} = 0.00 < 1.00 \quad (6.2.6-7)$$

$$V_{z,Ed}/V_{z,T,Rd} = 0.15 < 1.00 \quad (6.2.6-7)$$

$$\tau_{ty,Ed}/(f_y/(\sqrt{3}*gM0)) = 0.05 < 1.00 \quad (6.2.6)$$

$$\tau_{tz,Ed}/(f_y/(\sqrt{3}*gM0)) = 0.03 < 1.00 \quad (6.2.6)$$

Global stability check of member:

$$\lambda_{y} = 50.66 < \lambda_{max} = 210.00 \quad \lambda_{z} = 2.50 < \lambda_{max} = 210.00 \quad \text{STABLE}$$

$$M_{y,Ed,max}/M_{b,Rd} = 0.72 < 1.00 \quad (6.3.2.1.(1))$$

$$N_{Ed}/(X_y*N_{Rk}/gM1) + k_{yy}*M_{y,Ed,max}/(XLT*M_{y,Rk}/gM1) + k_{yz}*M_{z,Ed,max}/(M_{z,Rk}/gM1) = 0.67 < 1.00 \quad (6.3.3.(4))$$

$$N_{Ed}/(X_z*N_{Rk}/gM1) + k_{zy}*M_{y,Ed,max}/(XLT*M_{y,Rk}/gM1) + k_{zz}*M_{z,Ed,max}/(M_{z,Rk}/gM1) = 0.28 < 1.00 \quad (6.3.3.(4))$$

LIMIT DISPLACEMENTS**Deflections (LOCAL SYSTEM):**

$u_y = 0 \text{ mm} < u_{y \text{ max}} = L/200.00 = 42 \text{ mm}$ Verified

Governing Load Case: 8 Vjetar 4

$u_z = 5 \text{ mm} < u_{z \text{ max}} = L/200.00 = 42 \text{ mm}$ Verified

Governing Load Case: 378 COMB358 (1+2+4+10)*1.00+7*0.60

$u_{\text{inst},y} = 0 \text{ mm} < u_{\text{inst,max},y} = L/250.00 = 34 \text{ mm}$ Verified

Governing Load Case: 0.5*3 + 1*8 + 1*12

$u_{\text{inst},z} = 4 \text{ mm} < u_{\text{inst,max},z} = L/250.00 = 34 \text{ mm}$ Verified

Governing Load Case: 0.5*4 + 1*5 + 1*10



Displacements (GLOBAL SYSTEM): Not analyzed

Section OK !!!

GREDNI NOSAČ

Profil HEA340 , S275

$N_{c,Ed}$ 20,76 kN

$V_{z,Ed}$ 105,64 kN

$M_{y,Ed}$ 334,06 kNm

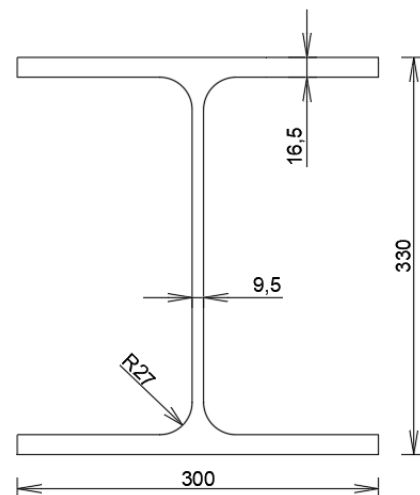

Karakteristike profila HEA 340

Profil	G	A	h	b	tw	tf	r	I_t	$I_w^* \cdot 10^{-3}$
	kg/m	cm ²	mm	mm	mm	mm	mm	cm ⁴	cm ⁶
HEA340	105	133,5	330	300	9,5	16,5	27	127,2	1824

I_y	W_y	$W_{pl,y}$	i_y	$A_{v,z}$	I_z	W_z	$W_{pl,z}$	i_z	$A_{v,y}$
cm ⁴	cm ³	cm ³	cm	cm ²	cm ⁴	cm ³	cm ³	cm	cm ²
27690	1678	1850	14,4	44,95	7436	495,7	755,9	7,46	102,5

Materijal – čelik kvalitete S275

2. Klasifikacija poprečnog presjeka

HRBAT

- Uvjet za klasu 1:

$$\frac{c}{t} = \frac{h - 2 \cdot t_f - 2 \cdot r}{t_w} = \frac{330 - 2 \cdot 16,5 - 2 \cdot 27}{9,5} = 25,58$$

$$a = \frac{N_{Ed}}{2 \cdot t_w \cdot \frac{f_y}{\gamma_{MO}}} = \frac{20,76}{2 \cdot 0,95 \cdot \frac{27,5}{1}} = 0,40 \text{ cm}$$

$$\alpha = \frac{1}{d} \cdot \left(\frac{d}{2} + a \right) = 0,52 ; \alpha > 0,5$$

$$d = h - 2 \cdot t_f - 2 \cdot r = 330 - 2 \cdot 16,5 - 2 \cdot 27 = 24,3 \text{ cm}$$

$$\frac{c}{t} \leq \frac{396 \varepsilon}{13\alpha - 1} ; 25,58 < 68,75$$

Hrbat je **klasa 1**.

POJASNICA

- Uvjet za klasu 1:

$$\frac{c}{t} = \frac{\frac{b}{2} - \frac{t_w}{2} - r}{t_f} = 7,17$$

$$\frac{c}{t} \leq 9 \varepsilon ; 7,17 < 8,28$$

Pojasnica je **klasa 1**.➔ Poprečni presjek je KLASA 1.2.6. Otpornost poprečnog presjeka na tlačnu siluProračunska tlačna sila $N_{c,Ed} = 20,76 \text{ kN}$

$$N_{c,Rd} = \frac{A \cdot f_y}{\gamma_{MO}} = \frac{133,5 \cdot 27,5}{1} = 3671,25 \text{ kN}$$

Uvjet nosivosti: $N_{Ed} \leq N_{c,Rd} ; 20,76 \text{ kN} < 3671,25 \text{ kN}$ **ZADOVOLJAVA (1%)**

2.7. Otpornost poprečnog presjeka na savijanjeProračunski moment savijanja $M_{y,Ed} = 334,06 \text{ kNm}$

$$\text{Proračunska nosivost moment savijanja } M_{c,Rd} = \frac{W_{pl,y} \cdot f_y}{\gamma_{M0}} = \frac{1850 \cdot 27,5}{1} = 508,75 \text{ kNm}$$

Uvjet nosivosti: $M_{y,Ed} \leq M_{c,Rd}$; $334,06 \text{ kNm} < 508,75 \text{ kNm}$ **ZADOVOLJAVA (66%)**2.8. Otpornost poprečnog presjeka na posmikProračunska poprečna sila $V_{z,Ed} = 105,64 \text{ kN}$ Provjera izbočivanja hrpta na posmik

$$\frac{h_w}{t_w} \leq 72 \frac{\epsilon}{\eta}$$

$$\frac{h_w}{t_w} = \frac{h-2 t_f}{t_w} = \frac{330-2 \cdot 16,5}{9,5} = 31,26$$

$$72 \cdot \frac{0,92}{1,2} = 55,2$$

 $31,26 < 55,2$ Nije potrebna provjera izbočivanja hrpta na posmik.

Posmična otpornosti

 $A_{v,z} = 44,95 \text{ cm}^2$

$$V_{pl,Rd} = \frac{A_{v,z} \cdot \frac{f_y}{\sqrt{3}}}{\gamma_{M0}} = \frac{44,95 \cdot 27,5/\sqrt{3}}{1,0} = 713,68 \text{ kN}$$

Uvjet nosivosti: $V_{z,Ed} \leq V_{pl,Rd}$; $105,64 \text{ kNm} < 713,68 \text{ kNm}$ **ZADOVOLJAVA (15%)**2.9. Interakcija M – N

Uvjet nereducirane plastične otpornosti na savijanje

$$N_{Ed} \leq 0,25 N_{c,Rd}$$

 $20,76 \text{ kN} < 0,25 \cdot 3671,25 = 917,81 \text{ kN}$ **ZADOVOLJAVA (2%)**

$$N_{Ed} \leq \frac{0,5 \cdot h_w \cdot t_w \cdot f_y}{\gamma_{M0}} = \frac{0,5 \cdot (33-2 \cdot 1,65) \cdot 0,95 \cdot 27,5}{1} ; 20,76 < 387,96 \text{ ZADOVOLJAVA (5%)}$$

Niska razina uzdužne sile – nema utjecaj na otpornost presjeka na savijanje $M_{V,N,y,Rd} = M_{pl,y,Rd}$ Uvjet nosivosti: $M_{y,Ed} \leq M_{V,N,y,Rd}$ $334,06 \text{ kNm} < 508,75 \text{ kNm}$ **ZADOVOLJAVA (66%)**

2.10. Interakcija M – V

Uvjet nereducirane plastične otpornosti na savijanje

$V_{z,Ed} \leq 0.5 V_{pl,Rd}$; $105,64 \text{ kNm} < 356,84 \text{ kNm} \rightarrow$ Nije potrebna redukcija plastične otpornosti na savijanje.

$$M_{y,V,Ed} = M_{pl,y,Rd}$$

Uvjet nosivosti: $M_{y,Ed} \leq M_{y,V,Rd}$; $334,06 \text{ kNm} < 508,75 \text{ kNm}$ **ZADOVOLJAVA** (66%)

3.4. Otpornost elementa na izvijanje

$$N_{b,Rd} = \chi \cdot \frac{A \cdot f_y}{\gamma_{M1}}$$

Oko osi y

$$N_{cr} = \frac{\pi^2 \cdot E \cdot I}{l_{cr}^2} = \frac{\pi^2 \cdot 21000 \cdot 27690}{850^2} = 7943,36 \text{ kN}$$

$$\lambda = \sqrt{\frac{A \cdot f_y}{N_{cr}}} = \sqrt{\frac{133,5 \cdot 27,5}{7943,36}} = 0,69$$

Određivanje mjerodavne linije izvijanja:

$$h/b = 330/300 = 1,1 < 1,2$$

Os y – y \rightarrow krivulja izvijanja b

Koeficijent nesavršenosti $\alpha = 0,34$

$$\Phi = 0,5 * [1 + \alpha * (\lambda - 0,2) + \lambda^2] = 0,5 * [1 + 0,34 * (0,69 - 0,2) + 0,69^2] = 0,82$$

$$\chi = \frac{1}{\Phi + \sqrt{\Phi^2 - \lambda^2}} = \frac{1}{0,82 + \sqrt{0,82^2 - 0,69^2}} = 0,79$$

Oko osi z

$$N_{cr} = \frac{\pi^2 \cdot E \cdot I}{l_{cr}^2} = \frac{\pi^2 \cdot 21000 \cdot 7436}{200^2} = 38529,95 \text{ kN}$$

$$\lambda = \sqrt{\frac{A \cdot f_y}{N_{cr}}} = \sqrt{\frac{133,5 \cdot 27,5}{38529,95}} = 0,31$$

$$h/b = 330/300 = 1,1 < 1,2$$

Os z – z \rightarrow krivulja izvijanja c

Koeficijent nesavršenosti $\alpha = 0,49$

$$\Phi = 0,5 * [1 + \alpha * (\lambda - 0,2) + \lambda^2] = 0,5 * [1 + 0,49 * (0,31 - 0,2) + 0,31^2] = 0,58$$

$$\chi = \frac{1}{\Phi + \sqrt{\Phi^2 - \lambda^2}} = \frac{1}{0,58 + \sqrt{0,58^2 - 0,31^2}} = 0,93$$

$$N_{b,Rd} = \chi \cdot \frac{A \cdot f_y}{\gamma_{M1}} = 0,79 \cdot \frac{133,5 \cdot 27,5}{1} = 2900,29 \text{ kN}$$

Uvjet nosivosti: $N_{c,Ed} \leq N_{b,Rd}$; $20,76 \text{ kN} < 2900,29 \text{ kN}$ **ZADOVOLJAVA**

3.5. Otpornost elementa na bočno torzijsko izvijanje

$$M_{cr} = C_1 \cdot \frac{\pi^2 \cdot E \cdot I_z}{(k \cdot L_{cr})^2} \cdot \left[\sqrt{\left(\frac{k}{k_w}\right)^2 \cdot \frac{I_w}{I_z} + \frac{(k \cdot L_{cr})^2 \cdot G \cdot I_t}{\pi^2 \cdot E \cdot I_z}} \right]$$

$$= 1,77 \cdot \frac{\pi^2 \cdot 21000 \cdot 7436}{(1 \cdot 200)^2} * \left[\sqrt{(1)^2 \cdot \frac{1824000}{7436} + \frac{(1 \cdot 200)^2 \cdot 8077 \cdot 127,2}{\pi^2 \cdot 21000 \cdot 7436}} \right]$$

$$M_{cr} = 1124663,53 \text{ kNcm}$$

Bezdimenzionalna bočna torzijska vitkost (svedena vitkost):

$$\overline{\lambda}_{LT} = \sqrt{\frac{W_{pl,y} \cdot f_y}{M_{cr}}} = \sqrt{\frac{1850 \cdot 27,5}{1124663,53}} = 0,212 < 0,4 \quad \text{- zdepasti nosač (bočno torzijsko izvijanje ne utječe na otpornosti nosača)}$$

Određivanje mjerodavne linije izvijanja:

$$\frac{h}{b} = \frac{330}{300} = 1,1 < 2$$

- krivulja izvijanja; a
- koeficijent nesavršenosti; $\alpha_{LT} = 0,2$

Koeficijent redukcije:

$$\chi_{LT} = 1$$

Uvjet nosivosti: $M_{y,Ed} \leq M_{b,Rd}$; $334,06 \text{ kNm} < 508,75 \text{ kNm}$ **ZADOVOLJAVA**

3.6. Interakcija izvijanja i bočno-torzijskog izvijanja (N – M)

Proračunski moment savijanja i proračunska uzdužna sila:

$$N_{c,Ed} = 20,76 \text{ kN}$$

$$M_{y,Ed} = 334,06 \text{ kNm}$$

Uvjeti koji moraju biti zadovoljeni:

$$\frac{N_{Ed}}{\chi_y \cdot \frac{N_{Rk}}{\gamma_{M1}}} + k_{yy} \cdot \frac{M_{y,Ed}}{\chi_{LT} \cdot \frac{M_{y,Rk}}{\gamma_{M1}}} \leq 1$$

$$\frac{N_{Ed}}{\chi_z \cdot \frac{N_{Rk}}{\gamma_{M1}}} + k_{zy} \cdot \frac{M_{y,Ed}}{\chi_{LT} \cdot \frac{M_{y,Rk}}{\gamma_{M1}}} \leq 1$$

Karakteristične vrijednosti nosivosti na tlak i moment savijanja:

$$N_{Rk} = A \cdot f_y = 133,5 \cdot 27,5 = 3671,25 \text{ kN}$$

$$M_{y,Rk} = W_{pl,y} \cdot f_y = 1850 \cdot 27,5 = 50875 \text{ kNcm} = 508,75 \text{ kNm}$$

Potrebni podaci za proračun interakcije:

$$\lambda_y = 0,69$$

$$\lambda_z = 0,85$$

$$\phi_y = 0,82$$

$$\phi_z = 0,31$$

$$\chi_y = 0,58$$

$$\chi_z = 0,93$$

Koeficijent C_{my} :

$$C_{my} = 0.6 + 0.4 \cdot \psi = 0.6$$

$$k_{yy} = C_{my} \cdot \left[1 + (\bar{\lambda}_y - 0.2) \cdot \frac{N_{Ed}}{\phi_y \cdot \frac{N_{Rk}}{\gamma_{M1}}} \right] \leq C_{my} \cdot \left(1 + 0.8 \cdot \frac{N_{Ed}}{\chi_y \cdot \frac{N_{Rk}}{\gamma_{M1}}} \right)$$

$$k_{yy} = 0.60 \cdot \left[1 + (0.69 - 0.2) \cdot \frac{20,76}{0,82 \cdot \frac{3671,25}{1,1}} \right] \leq 0.60 \cdot \left(1 + 0.8 \cdot \frac{20,76}{0,58 \cdot \frac{3671,25}{1,1}} \right)$$

$$k_{yy} = 0,602 < 0,605$$

Koeficijent interakcije k_{zy} :

$$k_{zy} = 0,60 \cdot k_{yy}$$

$$k_{zy} = 0,60 \cdot 0,602 = 0,361$$

Uvjeti interakcije:

$$\frac{N_{Ed}}{\chi_y \frac{N_{RK}}{\gamma_{M1}}} + k_{yy} \cdot \frac{M_{y,Ed}}{\chi_{LT} \frac{M_{y,Rk}}{\gamma_{M1}}} = \frac{20,76}{0,58 \cdot \frac{3671,25}{1,1}} + 0,602 \cdot \frac{334,06}{1 \cdot \frac{508,75}{1,1}} = 0,55 < 1 \quad \text{ZADOVOLJAVA}$$

$$\frac{N_{Ed}}{\chi_z \frac{N_{RK}}{\gamma_{M1}}} + k_{zy} \cdot \frac{M_{y,Ed}}{\chi_{LT} \frac{M_{y,Rk}}{\gamma_{M1}}} = \frac{20,76}{0,93 \cdot \frac{3671,25}{1,1}} + 0,361 \cdot \frac{334,06}{1 \cdot \frac{508,75}{1,1}} = 0,27 < 1 \quad \text{ZADOVOLJAVA}$$

Provjera progiba

Maksimalni progib od ukupnog djelovanja: $\delta_{inst,z} = 3,7 \text{ cm}$

Dopušteni progib: $\delta_{max,inst,z} = \frac{850}{200} = 4,25 \text{ cm}$

$$\delta_{inst,z} < \delta_{max,inst,z} ; 3,7 \text{ cm} < 4,25 \text{ cm} \quad \text{ZADOVOLJENO}$$

Maksimalni progib od promjenjivog djelovanja: $\delta_{inst,z} = 2,2 \text{ cm}$

Dopušteni progib: $\delta_{max,inst,z} = \frac{850}{250} = 3,4 \text{ cm}$

$$\delta_{inst,z} < \delta_{max,inst,z} ; 2,2 \text{ cm} < 3,4 \text{ cm} \quad \text{ZADOVOLJENO}$$

7.6. Gredni zabatni nosači

Na Slici 44. prikazan je položaj mjerodavnog grednog zabatnog nosača za dimenzioniranje, te vrijednosti na dijagramima za karakterističnu kombinaciju 42 (COMB22)

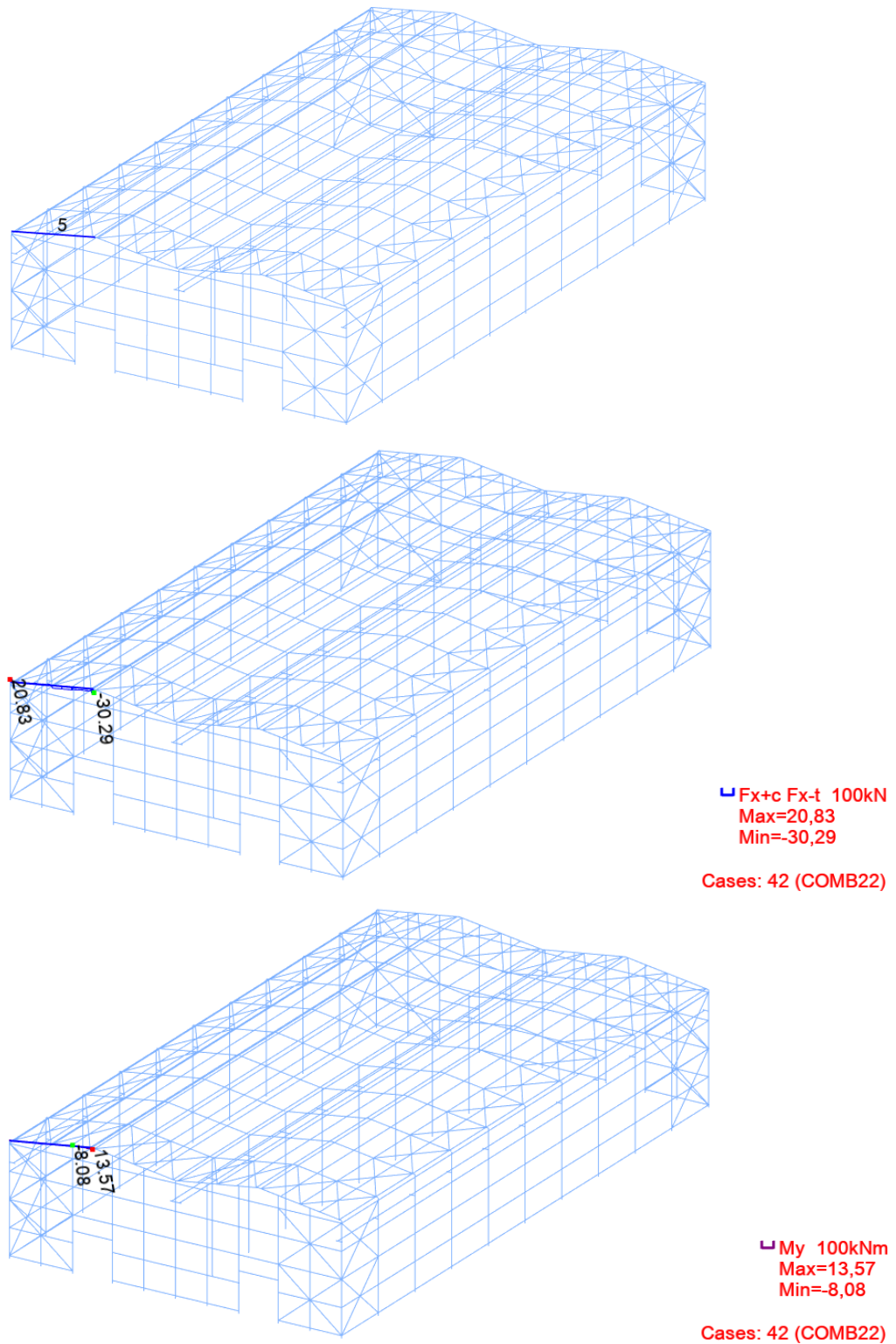

Slika 44. Položaj i vrijednosti dijagrama na zabatnom grednom nosaču mjerodavnom za dimenzioniranje [izradio autor]

STEEL DESIGN

CODE: EN 1993-1:2005/A1:2014, Eurocode 3: Design of steel structures.

ANALYSIS TYPE: Member Verification

CODE GROUP:

MEMBER: 5

POINT: 1

COORDINATE: $x = 0.24 L = 2.02$

m

LOADS:

Governing Load Case: 42 COMB22 (1+2)*1.35+8*1.50+4*0.75

MATERIAL:

S 355 (S 355) $f_y = 355.00$ MPa



SECTION PARAMETERS: IPE 330

h=330 mm	gM0=1.00	gM1=1.10	
b=160 mm	Ay=4228 mm ²	Az=3081 mm ²	Ax=6261 mm ²
tw=8 mm	Iy=117669000 mm ⁴	Iz=7881430 mm ⁴	Ix=257000 mm ⁴
tf=12 mm	Wply=804399 mm ³	Wplz=153683 mm ³	

INTERNAL FORCES AND CAPACITIES:

N,Ed = -22.33 kN	My,Ed = -5.92 kN*m	Mz,Ed = -2.78 kN*m	Vy,Ed = -17.86 kN
Nt,Rd = 2222.52 kN	My,pl,Rd = 285.56 kN*m	Mz,pl,Rd = 54.56 kN*m	Vy,T,Rd = 765.91 kN
	My,c,Rd = 285.56 kN*m	Mz,c,Rd = 54.56 kN*m	Vz,Ed = 1.54 kN
	MN,y,Rd = 285.56 kN*m	MN,z,Rd = 54.56 kN*m	Vz,T,Rd = 584.65 kN
	Mb,Rd = 232.24 kN*m		Tt,Ed = -1.25 kN*m
			Class of section = 1



LATERAL BUCKLING PARAMETERS:

z = 0.00	Mcr = 724.42 kN*m	Curve,LT - c	XLT = 0.87
Lcr,low=2.12 m	Lam_LT = 0.63	fi,LT = 0.70	XLT,mod = 0.89

BUCKLING PARAMETERS:



About y axis:



About z axis:

VERIFICATION FORMULAS:

Section strength check:

$$N_{Ed}/N_{t,Rd} = 0.01 < 1.00 \quad (6.2.3.(1))$$

$$M_{y,Ed}/M_{N,y,Rd} = 0.02 < 1.00 \quad (6.2.9.1.(2))$$

$$M_{z,Ed}/M_{N,z,Rd} = 0.05 < 1.00 \quad (6.2.9.1.(2))$$

$$(M_{y,Ed}/M_{N,y,Rd})^{2.00} + (M_{z,Ed}/M_{N,z,Rd})^{1.00} = 0.05 < 1.00 \quad (6.2.9.1.(6))$$

$$V_{y,Ed}/V_{y,T,Rd} = 0.02 < 1.00 \quad (6.2.6-7)$$

$$V_{z,Ed}/V_{z,T,Rd} = 0.00 < 1.00 \quad (6.2.6-7)$$

$$\tau_{u,ty,Ed}/(f_y/(\sqrt{3})gM0) = 0.27 < 1.00 \quad (6.2.6)$$

$$\tau_{u,tz,Ed}/(f_y/(\sqrt{3})gM0) = 0.18 < 1.00 \quad (6.2.6)$$

Global stability check of member:

$$M_{y,Ed}/M_{b,Rd} = 0.03 < 1.00 \quad (6.3.2.1.(1))$$

LIMIT DISPLACEMENTS



Deflections (LOCAL SYSTEM):

$$u_y = 2 \text{ mm} < u_{y \text{ max}} = L/200.00 = 42 \text{ mm} \quad \text{Verified}$$

Governing Load Case: 5 Vjetar 1

$$u_z = 1 \text{ mm} < u_{z \text{ max}} = L/200.00 = 42 \text{ mm} \quad \text{Verified}$$

Governing Load Case: 260 COMB240 (1+2+4)*1.00

$u_{inst,y} = 2 \text{ mm} < u_{inst,max,y} = L/250.00 = 34 \text{ mm}$

Verified

Governing Load Case: 0.5*3 + 1*5 + 1*9

$u_{inst,z} = 1 \text{ mm} < u_{inst,max,z} = L/250.00 = 34 \text{ mm}$

Verified

Governing Load Case: 1*5



Displacements (GLOBAL SYSTEM): Not analyzed

Section OK !!!

7.7. Podrožnice

Na Slici 45. prikazan je položaj mjerodavne podrožnice za dimenzioniranje, te vrijednosti na dijagramima za karakterističnu kombinaciju 223 (COMB203)

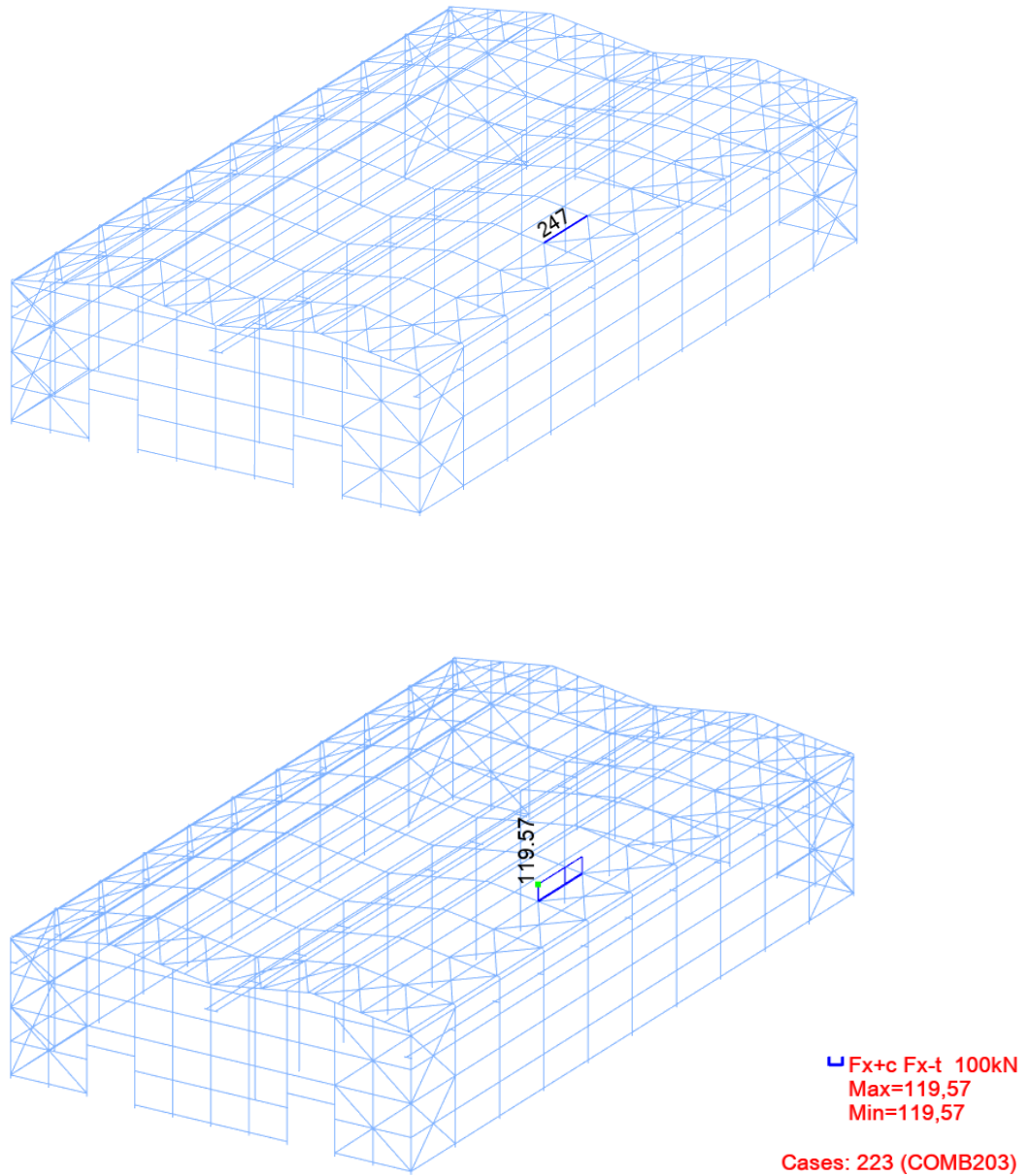

Slika 45. Položaj i vrijednosti dijagrama na podrožnici mjerodavnoj za dimenzioniranje
[izradio autor]

STEEL DESIGN

CODE: EN 1993-1:2005/A1:2014, Eurocode 3: Design of steel structures.

ANALYSIS TYPE: Member Verification

CODE GROUP:

MEMBER: 247

POINT: 1

COORDINATE: x = 0.00 L = 0.00

m

LOADS:

Governing Load Case: 223 COMB203 (1+2)*1.35+(6+9)*1.50+4*0.75

MATERIAL:

S 275 (S 275) $f_y = 275.00$ MPa



SECTION PARAMETERS: IPE 270

h=270 mm	gM0=1.00	gM1=1.10	
b=135 mm	Ay=3145 mm ²	Az=2214 mm ²	Ax=4595 mm ²
tw=7 mm	Iy=57897800 mm ⁴	Iz=4198690 mm ⁴	Ix=149300 mm ⁴
tf=10 mm	Wply=484035 mm ³	Wplz=96953 mm ³	

INTERNAL FORCES AND CAPACITIES:

N,Ed = 119.57 kN	My,Ed = -5.57 kN*m	Mz,Ed = 0.15 kN*m	Vy,Ed = 0.06 kN
Nc,Rd = 1263.49 kN	My,Ed,max = -5.57 kN*m	Mz,Ed,max = -0.19 kN*m	Vy,T,Rd = 499.34 kN
Nb,Rd = 189.05 kN	My,c,Rd = 133.11 kN*m	Mz,c,Rd = 26.66 kN*m	Vz,Ed = 4.53 kN
	MN,y,Rd = 133.11 kN*m	MN,z,Rd = 26.66 kN*m	Vz,T,Rd = 351.48 kN
	Mb,Rd = 59.48 kN*m		Tt,Ed = -0.00 kN*m
			Class of section = 1



LATERAL BUCKLING PARAMETERS:

z = 0.00	Mcr = 70.70 kN*m	Curve,LT - b	XLT = 0.49
Lcr,low=6.00 m	Lam_LT = 1.37	fi,LT = 1.37	XLT,mod = 0.49

BUCKLING PARAMETERS:



About y axis:

Ly = 6.00 m	Lam_y = 0.62
Lcr,y = 6.00 m	Xy = 0.88
Lamy = 53.45	kzy = 0.82



About z axis:

Lz = 6.00 m	Lam_z = 2.29
Lcr,z = 6.00 m	Xz = 0.16
Lamz = 198.48	kzz = 1.57

Torsional buckling:

Curve,T=b	alfa,T=0.34
Lt=6.00 m	fi,T=1.17
Ncr,T=1194.03 kN	X,T=0.58
Lam_T=1.03	Nb,T,Rd=664.98 kN

Flexural-torsional buckling

Curve,TF=b	alfa,TF=0.34
Ncr,y=3333.33 kN	fi,TF=0.76
Ncr,TF=3333.33 kN	X,TF=0.83
Lam_TF=0.62	Nb,TF,Rd=952.35 kN

VERIFICATION FORMULAS:

Section strength check:

$N_{Ed}/N_{c,Rd} = 0.09 < 1.00$ (6.2.4.(1))
$M_{y,Ed}/M_{N,y,Rd} = 0.04 < 1.00$ (6.2.9.1.(2))
$M_{z,Ed}/M_{N,z,Rd} = 0.01 < 1.00$ (6.2.9.1.(2))
$(M_{y,Ed}/M_{N,y,Rd})^2 + (M_{z,Ed}/M_{N,z,Rd})^1 = 0.01 < 1.00$ (6.2.9.1.(6))
$V_{y,Ed}/V_{y,T,Rd} = 0.00 < 1.00$ (6.2.6-7)
$V_{z,Ed}/V_{z,T,Rd} = 0.01 < 1.00$ (6.2.6-7)
$\tau_{t,y,Ed}/(f_y/(\sqrt{3}*gM0)) = 0.00 < 1.00$ (6.2.6)
$\tau_{t,z,Ed}/(f_y/(\sqrt{3}*gM0)) = 0.00 < 1.00$ (6.2.6)

Global stability check of member:

$\Lambda_{y} = 53.45 < \Lambda_{\max} = 210.00$ $\Lambda_{z} = 198.48 < \Lambda_{\max} = 210.00$ STABLE

$N_{Ed}/\text{Min}(N_b, R_d, N_b, T, R_d, N_b, T, F, R_d) = 0.63 < 1.00$ (6.3.1)

$M_{y,Ed,\max}/M_{b,Rd} = 0.09 < 1.00$ (6.3.2.1.(1))

$N_{Ed}/(X_y \cdot N_{Rk}/gM1) + k_{yy} \cdot M_{y,Ed,\max}/(X_{LT} \cdot M_{y,Rk}/gM1) + k_{yz} \cdot M_{z,Ed,\max}/(M_{z,Rk}/gM1) = 0.30 < 1.00$
(6.3.3.(4))

$N_{Ed}/(X_z \cdot N_{Rk}/gM1) + k_{zy} \cdot M_{y,Ed,\max}/(X_{LT} \cdot M_{y,Rk}/gM1) + k_{zz} \cdot M_{z,Ed,\max}/(M_{z,Rk}/gM1) = 0.72 < 1.00$
(6.3.3.(4))

LIMIT DISPLACEMENTS**Deflections (LOCAL SYSTEM):**

$u_y = 0 \text{ mm} < u_{y \max} = L/200.00 = 30 \text{ mm}$ Verified

Governing Load Case: 437 COMB418 (1+2+8+9)*1.00+3*0.50 Verified

$u_z = 1 \text{ mm} < u_{z \max} = L/200.00 = 30 \text{ mm}$ Verified

Governing Load Case: 259 COMB239 (1+2+3)*1.00 Verified

$u_{\text{inst},y} = 0 \text{ mm} < u_{\text{inst},\max,y} = L/250.00 = 24 \text{ mm}$ Verified

Governing Load Case: 0.5*3 + 1*8 + 1*9 Verified

$u_{\text{inst},z} = 0 \text{ mm} < u_{\text{inst},\max,z} = L/200.00 = 30 \text{ mm}$ Verified

Governing Load Case: 0.5*4 + 1*5 + 1*17



Displacements (GLOBAL SYSTEM): Not analyzed

Section OK !!!

7.8. Zabatni stupovi

Na Slici 46. prikazan je položaj mjerodavnog zabatnog stupa za dimenzioniranje, te vrijednosti na dijagramima za karakterističnu kombinaciju 215 (COMB195)

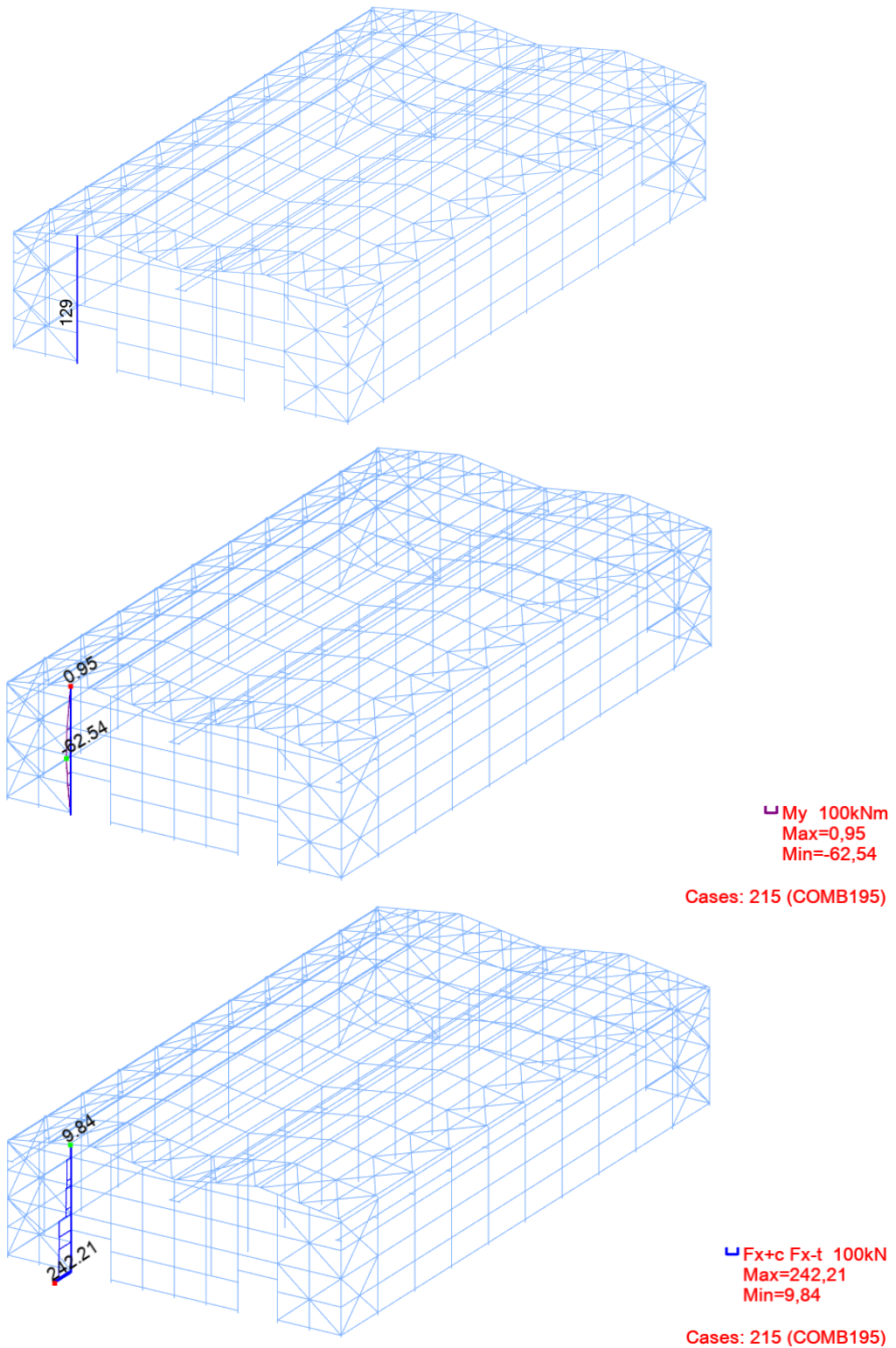

Slika 46. Položaj i vrijednosti dijagrama na zabatnom stupu mjerodavnom za dimenzioniranje [izradio autor]

STEEL DESIGN

CODE: EN 1993-1:2005/A1:2014, Eurocode 3: Design of steel structures.

ANALYSIS TYPE: Member Verification

CODE GROUP:

MEMBER: 129

POINT: 1

COORDINATE: $x = 0.34 L = 4.00$

m

LOADS:

Governing Load Case: 215 COMB195 (1+2)*1.35+(5+13)*1.50+4*0.75

MATERIAL:

S 275 (S 275) $f_y = 275.00$ MPa



SECTION PARAMETERS: IPE 330

h=330 mm	gM0=1.00	gM1=1.10	
b=160 mm	Ay=4228 mm ²	Az=3081 mm ²	Ax=6261 mm ²
tw=8 mm	Iy=117669000 mm ⁴	Iz=7881430 mm ⁴	Ix=257000 mm ⁴
tf=12 mm	Wply=804399 mm ³	Wplz=153683 mm ³	

INTERNAL FORCES AND CAPACITIES:

N,Ed = 178.35 kN	My,Ed = -50.95 kN*m	Mz,Ed = 5.46 kN*m	Vy,Ed = 5.11 kN
Nc,Rd = 1721.67 kN	My,Ed,max = -62.23 kN*m	Mz,Ed,max = 5.46 kN*m	Vy,T,Rd = 668.77 kN
Nb,Rd = 967.41 kN	My,c,Rd = 221.21 kN*m	Mz,c,Rd = 42.26 kN*m	Vz,Ed = -7.73 kN
	MN,y,Rd = 221.21 kN*m	MN,z,Rd = 42.26 kN*m	Vz,T,Rd = 487.95 kN
	Mb,Rd = 165.45 kN*m		Tt,Ed = 0.03 kN*m
			Class of section = 1



LATERAL BUCKLING PARAMETERS:

z = 0.00	Mcr = 398.93 kN*m	Curve,LT - c	XLT = 0.80
Lcr,low=2.98 m	Lam_LT = 0.74	fi,LT = 0.79	XLT,mod = 0.82

BUCKLING PARAMETERS:



About y axis:

Ly = 11.91 m	Lam_y = 1.00
Lcr,y = 11.91 m	Xy = 0.66
Lamy = 86.91	kyy = 1.18



About z axis:

Lz = 11.91 m	Lam_z = 0.97
Lcr,z = 2.98 m	Xz = 0.62
Lamz = 83.95	kyz = 0.90

Torsional buckling:

Curve,T=b	alfa,T=0.34
Lt=2.98 m	fi,T=0.84
Ncr,T=3363.53 kN	X,T=0.77
Lam_T=0.72	Nb,T,Rd=1212.86 kN

Flexural-torsional buckling

Curve,TF=b	alfa,TF=0.34
Ncr,y=1718.08 kN	fi,TF=1.14
Ncr,TF=1718.08 kN	X,TF=0.60
Lam_TF=1.00	Nb,TF,Rd=933.40 kN

VERIFICATION FORMULAS:

Section strength check:

$N_{Ed}/N_{c,Rd} = 0.10 < 1.00$ (6.2.4.(1))
$M_{y,Ed}/M_{N,y,Rd} = 0.23 < 1.00$ (6.2.9.1.(2))
$M_{z,Ed}/M_{N,z,Rd} = 0.13 < 1.00$ (6.2.9.1.(2))
$(M_{y,Ed}/M_{N,y,Rd})^2 + (M_{z,Ed}/M_{N,z,Rd})^1 = 0.18 < 1.00$ (6.2.9.1.(6))
$V_{y,Ed}/V_{y,T,Rd} = 0.01 < 1.00$ (6.2.6-7)
$V_{z,Ed}/V_{z,T,Rd} = 0.02 < 1.00$ (6.2.6-7)
$\tau_{t,y,Ed}/(f_y/(\sqrt{3}*gM0)) = 0.01 < 1.00$ (6.2.6)
$\tau_{t,z,Ed}/(f_y/(\sqrt{3}*gM0)) = 0.01 < 1.00$ (6.2.6)

Global stability check of member:

$\Lambda_{y} = 86.91 < \Lambda_{max} = 210.00$ $\Lambda_{z} = 83.95 < \Lambda_{max} = 210.00$ STABLE

$N_{Ed}/\min(N_b, R_d, N_b, T, R_d, N_b, T, F, R_d) = 0.19 < 1.00$ (6.3.1)

$M_{y,Ed,max}/M_b, R_d = 0.38 < 1.00$ (6.3.2.1.(1))

$N_{Ed}/(X_y \cdot N_{Rk}/gM1) + k_{yy} \cdot M_{y,Ed,max}/(X_{LT} \cdot M_{y,Rk}/gM1) + k_{yz} \cdot M_{z,Ed,max}/(M_{z,Rk}/gM1) = 0.74 < 1.00$
(6.3.3.(4))

$N_{Ed}/(X_z \cdot N_{Rk}/gM1) + k_{zy} \cdot M_{y,Ed,max}/(X_{LT} \cdot M_{y,Rk}/gM1) + k_{zz} \cdot M_{z,Ed,max}/(M_{z,Rk}/gM1) = 0.59 < 1.00$
(6.3.3.(4))

LIMIT DISPLACEMENTS
**Deflections (LOCAL SYSTEM):**

$u_y = 1 \text{ mm} < u_y \text{ max} = L/200.00 = 60 \text{ mm}$ Verified

Governing Load Case: 465 COMB446 (1+2+6+13)*1.00+4*0.50

$u_z = 27 \text{ mm} < u_z \text{ max} = L/200.00 = 60 \text{ mm}$ Verified

Governing Load Case: 494 COMB476 (1+2+8+18)*1.00+4*0.50

$u_{inst,y} = 1 \text{ mm} < u_{inst,max,y} = L/250.00 = 48 \text{ mm}$ Verified

Governing Load Case: 0.5*4 + 1*6 + 1*13

$u_{inst,z} = 26 \text{ mm} < u_{inst,max,z} = L/250.00 = 48 \text{ mm}$ Verified

Governing Load Case: 0.5*4 + 1*8 + 1*18

**Displacements (GLOBAL SYSTEM):**

$v_x = 13 \text{ mm} < v_x \text{ max} = L/150.00 = 79 \text{ mm}$ Verified

Governing Load Case: 465 COMB446 (1+2+6+13)*1.00+4*0.50

$v_y = 10 \text{ mm} < v_y \text{ max} = L/150.00 = 79 \text{ mm}$ Verified

Governing Load Case: 486 COMB468 (1+2+8+10)*1.00+4*0.50

Section OK !!!

7.9. Krovni uzdužni vezovi

Na Slici 47. prikazan je položaj mjerodavnog krovnog uzdužnog veza za dimenzioniranje, te vrijednosti na dijagramima za karakterističnu kombinaciju 223 (COMB203)

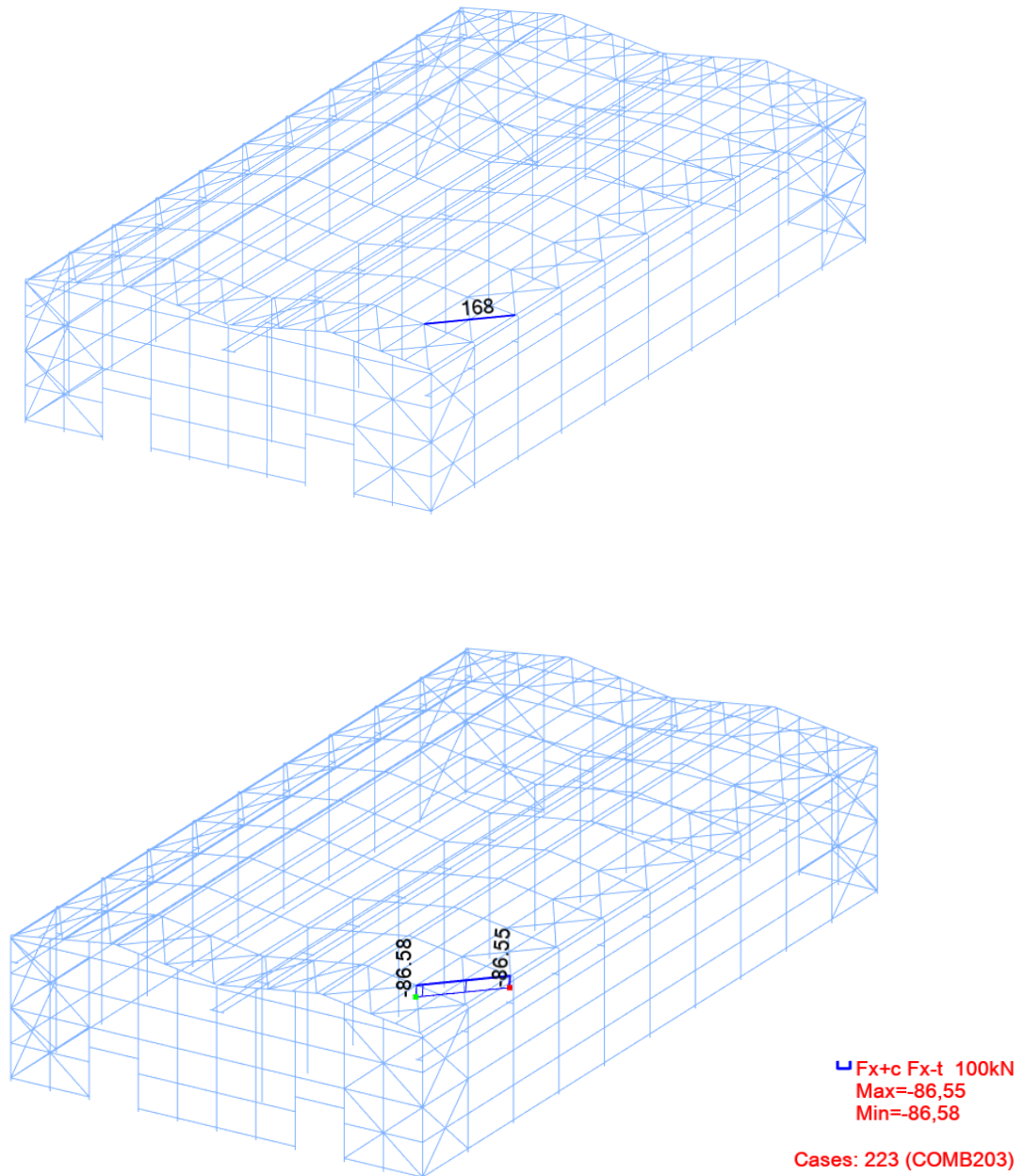

Slika 47. Položaj i vrijednosti dijagrama na uzdužnom krovnom vezu mjerodavnom za dimenzioniranje [izradio autor]

STEEL DESIGN

CODE: EN 1993-1:2005/A1:2014, Eurocode 3: Design of steel structures.

ANALYSIS TYPE: Member Verification

CODE GROUP:

MEMBER: 168

POINT: 2

COORDINATE: $x = 0.50 L = 3.61$

m

LOADS:

Governing Load Case: 223 COMB203 (1+2)*1.35+(6+9)*1.50+4*0.75

MATERIAL:

S 275 (S 275) $f_y = 275.00$ MPa



SECTION PARAMETERS: Okrugli puni profil d = 25 mm

$h = 25$ mm

$gM0 = 1.00$

$gM1 = 1.10$

$A_y = 313$ mm²

$A_z = 313$ mm²

$A_x = 491$ mm²

$t_w = 13$ mm

$I_y = 19175$ mm⁴

$I_z = 19175$ mm⁴

$I_x = 38350$ mm⁴

$W_{ply} = 2604$ mm³

$W_{plz} = 2604$ mm³

INTERNAL FORCES AND CAPACITIES:

$N_{Ed} = -86.56$ kN

$M_{y,Ed} = 0.33$ kN*m

$N_{t,Rd} = 134.99$ kN

$M_{y,pl,Rd} = 0.72$ kN*m

$M_{y,c,Rd} = 0.72$ kN*m

$MN_{y,Rd} = 0.38$ kN*m

Class of section = 1



LATERAL BUCKLING PARAMETERS:

BUCKLING PARAMETERS:



About y axis:



About z axis:

VERIFICATION FORMULAS:

Section strength check:

$N_{Ed}/N_{t,Rd} = 0.64 < 1.00$ (6.2.3.(1))

$M_{y,Ed}/M_{y,c,Rd} = 0.46 < 1.00$ (6.2.5.(1))

$M_{y,Ed}/MN_{y,Rd} = 0.87 < 1.00$ (6.2.9.1.(2))

Section OK !!!

7.10. Krovni poprečni vezovi

Na Slici 48. prikazan je položaj mjerodavnog krovnog poprečnog veza za dimenzioniranje, te vrijednosti na dijagramima za karakterističnu kombinaciju 234 (COMB214)

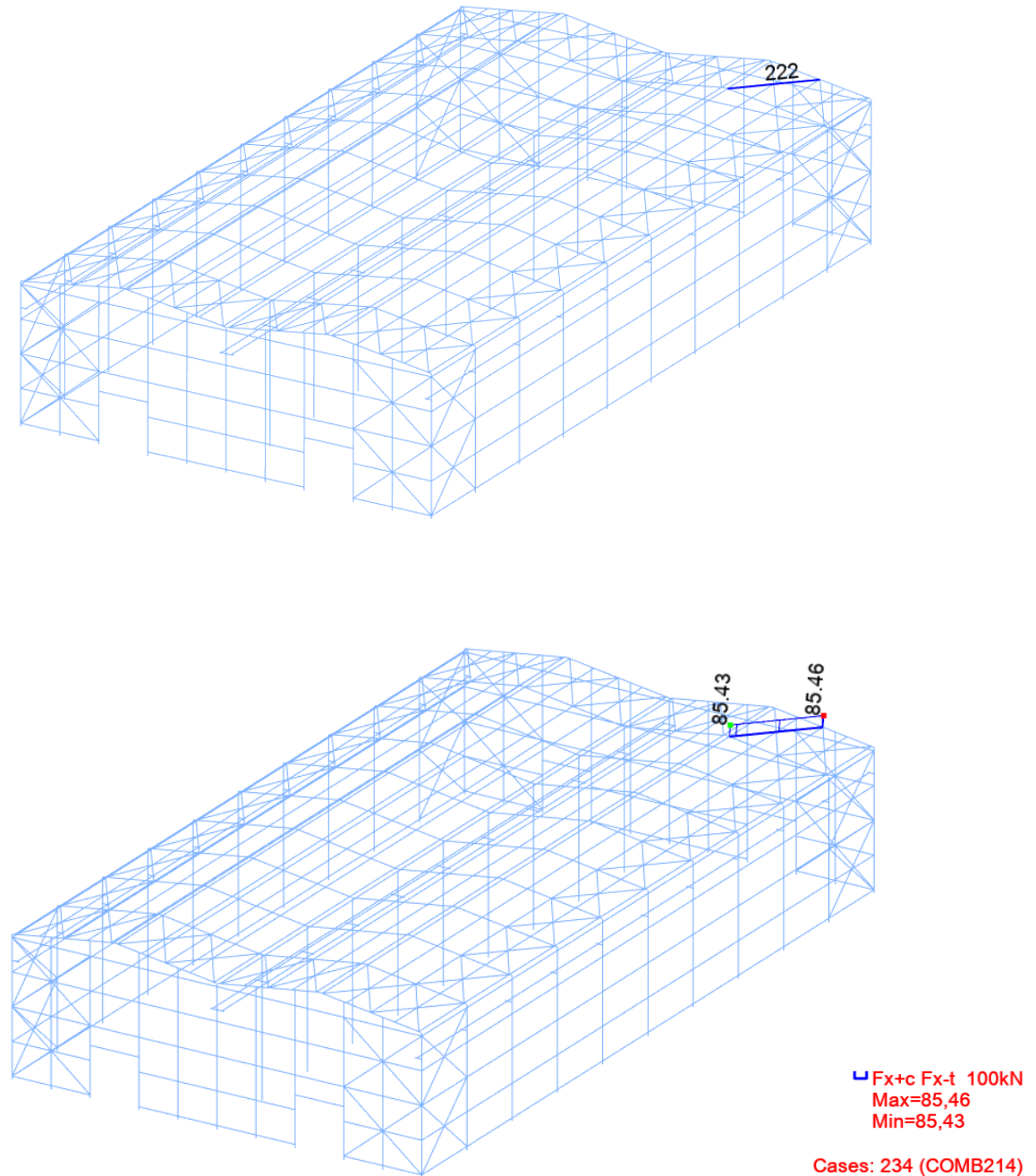

Slika 48. Položaj i vrijednosti dijagrama na poprečnom krovnom vezu mjerodavnom za dimenzioniranje [izradio autor]

STEEL DESIGN

CODE: EN 1993-1:2005/A1:2014, Eurocode 3: Design of steel structures.

ANALYSIS TYPE: Member Verification

CODE GROUP:

MEMBER: 222

POINT: 2

COORDINATE: $x = 0.50 L = 3.61$

m

LOADS:

Governing Load Case: 234 COMB214 (1+2)*1.35+(6+20)*1.50+4*0.75

MATERIAL:

S 275 (S 275) $f_y = 275.00$ MPa



SECTION PARAMETERS: Okrugli puni profil d = 25 mm

h=25 mm	gM0=1.00	gM1=1.10	
	Ay=313 mm ²	Az=313 mm ²	Ax=491 mm ²
tw=13 mm	Iy=19175 mm ⁴	Iz=19175 mm ⁴	Ix=38350 mm ⁴
	Wply=2604 mm ³	Wplz=2604 mm ³	

INTERNAL FORCES AND CAPACITIES:

N,Ed = 85.45 kN	My,Ed = 0.33 kN*m
Nc,Rd = 134.99 kN	My,pl,Rd = 0.72 kN*m
Nb,Rd = 122.72 kN	My,c,Rd = 0.72 kN*m
	MN,y,Rd = 0.39 kN*m

Class of section = 1



LATERAL BUCKLING PARAMETERS:

BUCKLING PARAMETERS:



About y axis:



About z axis:

VERIFICATION FORMULAS:

Section strength check:

$$N_{Ed}/N_{c,Rd} = 0.63 < 1.00 \quad (6.2.4.(1))$$

$$M_{y,Ed}/M_{y,c,Rd} = 0.46 < 1.00 \quad (6.2.5.(1))$$

$$M_{y,Ed}/M_{N,y,Rd} = 0.85 < 1.00 \quad (6.2.9.1.(2))$$

Section OK !!!

7.11. Vertikalni uzdužni vezovi

Na Slici 49. prikazan je položaj mjerodavnog vertikalnog uzdužnog veza za dimenzioniranje, te vrijednosti na dijagramima za karakterističnu kombinaciju 235 (COMB215)

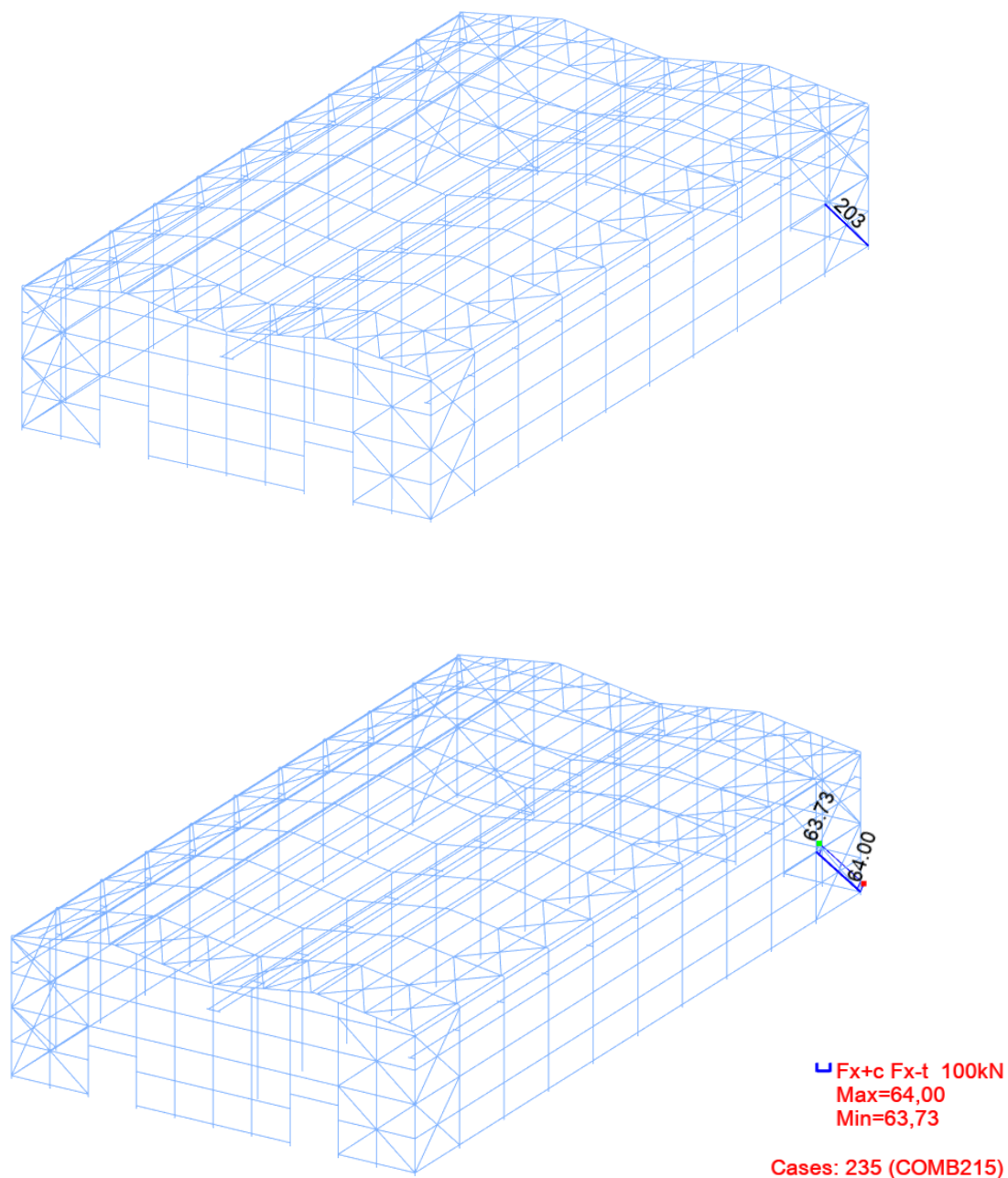

Slika 49. Položaj i vrijednosti dijagrama na vertikalnom uzdužnom vezu mjerodavnom za dimenzioniranje [izradio autor]

STEEL DESIGN

CODE: EN 1993-1:2005/A1:2014, Eurocode 3: Design of steel structures.

ANALYSIS TYPE: Member Verification

CODE GROUP:

MEMBER: 203

POINT: 3

COORDINATE: x = 1.00 L = 7.97

m

LOADS:

Governing Load Case: 235 COMB215 (1+2)*1.35+(7+9)*1.50+4*0.75

MATERIAL:

S 275 (S 275) $f_y = 275.00$ MPa



SECTION PARAMETERS: Okrugli puni profil d = 25 mm

h=25 mm	gM0=1.00	gM1=1.10	
	Ay=313 mm ²	Az=313 mm ²	Ax=491 mm ²
tw=13 mm	Iy=19175 mm ⁴	Iz=19175 mm ⁴	Ix=38350 mm ⁴
	Wply=2604 mm ³	Wplz=2604 mm ³	

INTERNAL FORCES AND CAPACITIES:

N,Ed = 64.00 kN	My,Ed = -0.21 kN*m	Mz,Ed = 0.00 kN*m	Vy,Ed = -0.00 kN
Nc,Rd = 134.99 kN	My,pl,Rd = 0.72 kN*m	Mz,pl,Rd = 0.72 kN*m	Vy,T,Rd = 49.57 kN
Nb,Rd = 122.72 kN	My,c,Rd = 0.72 kN*m	Mz,c,Rd = 0.72 kN*m	Vz,Ed = -0.15 kN
	MN,y,Rd = 0.51 kN*m	MN,z,Rd = 0.51 kN*m	Vz,T,Rd = 49.57 kN
			Tt,Ed = -0.00 kN*m
			Class of section = 1



LATERAL BUCKLING PARAMETERS:

BUCKLING PARAMETERS:



About y axis:



About z axis:

VERIFICATION FORMULAS:

Section strength check:

$$N_{Ed}/N_{c,Rd} = 0.47 < 1.00 \quad (6.2.4.(1))$$

$$M_{y,Ed}/M_{N,y,Rd} = 0.40 < 1.00 \quad (6.2.9.1.(2))$$

$$M_{z,Ed}/M_{N,z,Rd} = 0.01 < 1.00 \quad (6.2.9.1.(2))$$

$$(M_{y,Ed}/M_{N,y,Rd})^{2.00} + (M_{z,Ed}/M_{N,z,Rd})^{2.00} = 0.16 < 1.00 \quad (6.2.9.1.(6))$$

$$V_{y,Ed}/V_{y,T,Rd} = 0.00 < 1.00 \quad (6.2.6-7)$$

$$V_{z,Ed}/V_{z,T,Rd} = 0.00 < 1.00 \quad (6.2.6-7)$$

$$\tau_{y,t,Ed}/(f_y/(\sqrt{3})gM0) = 0.00 < 1.00 \quad (6.2.6)$$

$$\tau_{z,t,Ed}/(f_y/(\sqrt{3})gM0) = 0.00 < 1.00 \quad (6.2.6)$$

Section OK !!!

7.12. Vertikalni poprečni vezovi

Na Slici 50. prikazan je položaj mjerodavnog vertikalnog poprečnog veza za dimenzioniranje, te vrijednosti na dijagramima za karakterističnu kombinaciju 227 (COMB207)

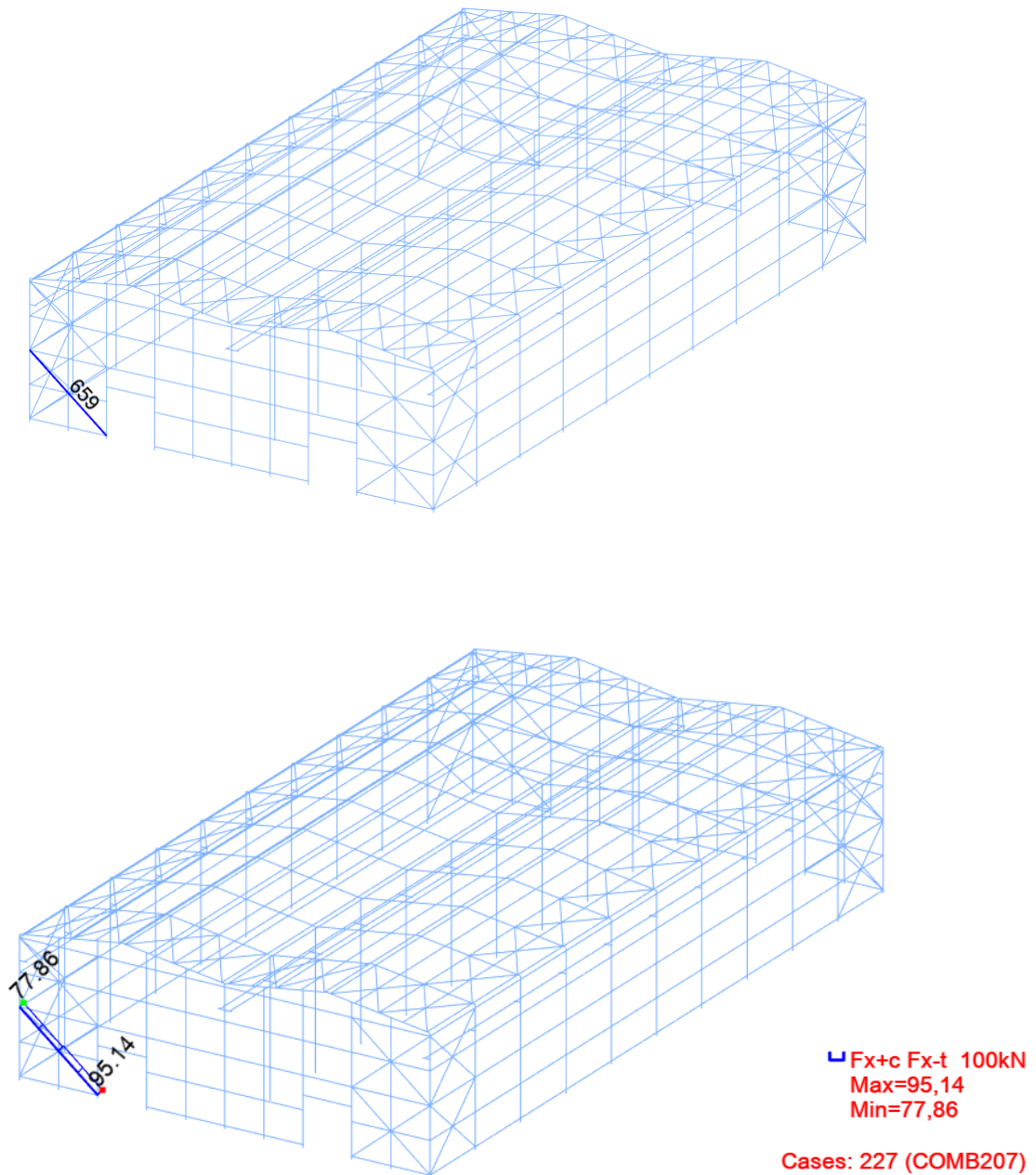

Slika 50. Položaj i vrijednosti dijagrama na vertikalnom poprečnom vezu mjerodavnom za dimenzioniranje [izradio autor]

STEEL DESIGN

CODE: EN 1993-1:2005/A1:2014, Eurocode 3: Design of steel structures.

ANALYSIS TYPE: Member Verification

CODE GROUP:

MEMBER: 655 Krovni porecni vezovi_655

POINT: 1

COORDINATE: x = 0.00 L = 0.00 m

LOADS:

Governing Load Case: 227 COMB207 (1+2)*1.35+(6+13)*1.50+4*0.75

MATERIAL:

S 275 (S 275) $f_y = 275.00$ MPa



SECTION PARAMETERS: Okrugli puni profil d = 25 mm

h=25 mm	gM0=1.00	gM1=1.10	
	Ay=313 mm ²	Az=313 mm ²	Ax=491 mm ²
tw=13 mm	Iy=19175 mm ⁴	Iz=19175 mm ⁴	Ix=38350 mm ⁴
	Wply=2604 mm ³	Wplz=2604 mm ³	

INTERNAL FORCES AND CAPACITIES:

N,Ed = 95.14 kN	My,Ed = -0.06 kN*m	Mz,Ed = -0.00 kN*m	Vy,Ed = -0.00 kN
Nc,Rd = 134.99 kN	My,pl,Rd = 0.72 kN*m	Mz,pl,Rd = 0.72 kN*m	Vy,T,Rd = 49.60 kN
Nb,Rd = 122.72 kN	My,c,Rd = 0.72 kN*m	Mz,c,Rd = 0.72 kN*m	Vz,Ed = 0.08 kN
	MN,y,Rd = 0.31 kN*m	MN,z,Rd = 0.31 kN*m	Vz,T,Rd = 49.60 kN
			Tt,Ed = 0.00 kN*m
			Class of section = 1



LATERAL BUCKLING PARAMETERS:

BUCKLING PARAMETERS:



About y axis:



About z axis:

VERIFICATION FORMULAS:

Section strength check:

$$N_{Ed}/N_{c,Rd} = 0.71 < 1.00 \quad (6.2.4.(1))$$

$$M_{y,Ed}/M_{N,y,Rd} = 0.20 < 1.00 \quad (6.2.9.1.(2))$$

$$M_{z,Ed}/M_{N,z,Rd} = 0.01 < 1.00 \quad (6.2.9.1.(2))$$

$$(M_{y,Ed}/M_{N,y,Rd})^{2.00} + (M_{z,Ed}/M_{N,z,Rd})^{2.00} = 0.04 < 1.00 \quad (6.2.9.1.(6))$$

$$V_{y,Ed}/V_{y,T,Rd} = 0.00 < 1.00 \quad (6.2.6-7)$$

$$V_{z,Ed}/V_{z,T,Rd} = 0.00 < 1.00 \quad (6.2.6-7)$$

$$\tau_{y,Ed}/(f_y/(\sqrt{3}*gM0)) = 0.00 < 1.00 \quad (6.2.6)$$

$$\tau_{z,Ed}/(f_y/(\sqrt{3}*gM0)) = 0.00 < 1.00 \quad (6.2.6)$$

Section OK !!!

7.13. Horizontalni nosači obloge (zabatni)

Na Slici 51. prikazan je položaj mjerodavnog zabatnog horizontalnog nosača obloge za dimenzioniranje, te vrijednosti na dijagramima za karakterističnu kombinaciju 166 (COMB146)

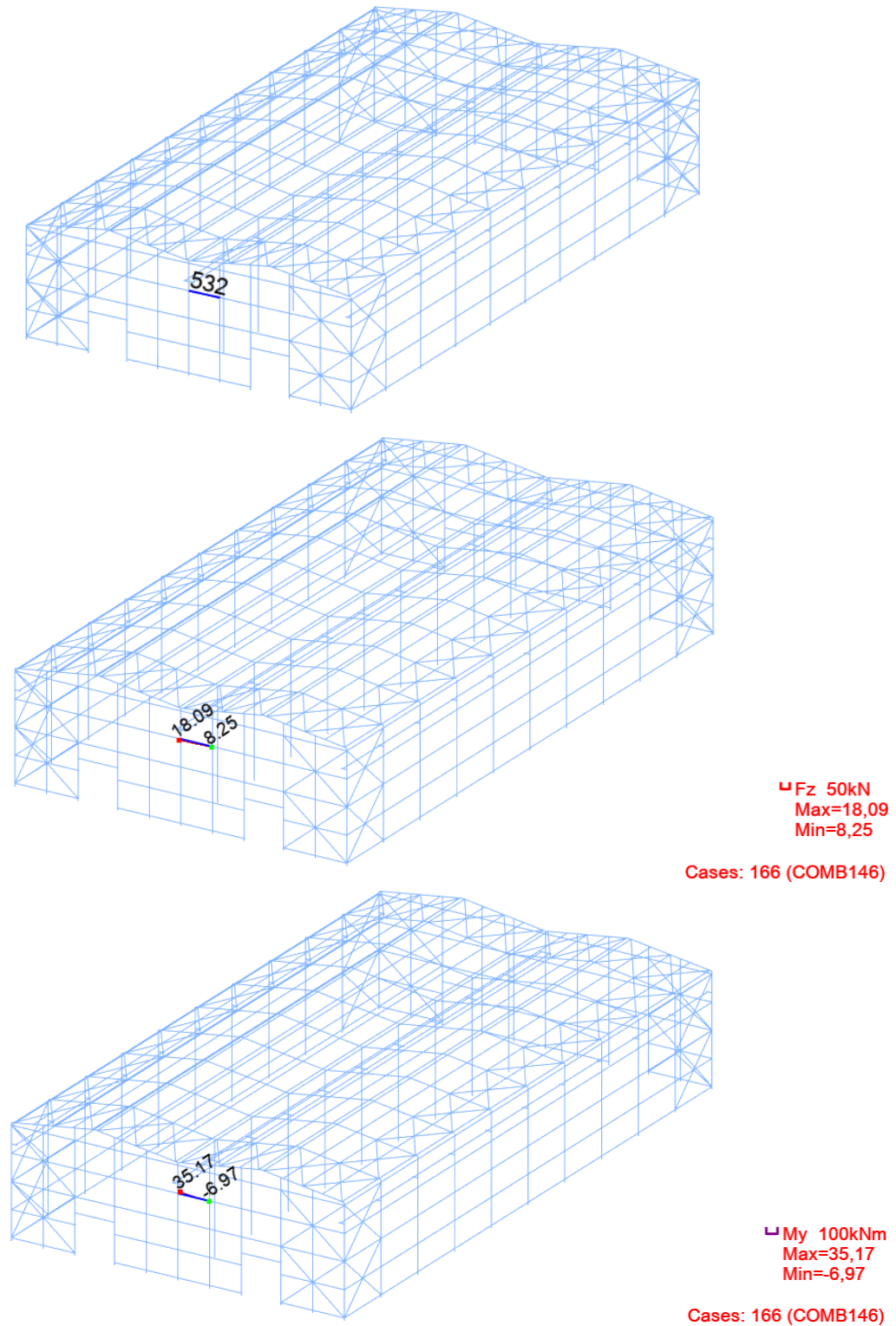

Slika 51. Položaj i vrijednosti dijagrama na horizontalnom zabatnom nosaču obloge mjerodavnom za dimenzioniranje [izradio autor]

STEEL DESIGN

CODE: EN 1993-1:2005/A1:2014, Eurocode 3: Design of steel structures.

ANALYSIS TYPE: Member Verification

CODE GROUP:

MEMBER: 532

POINT: 3

COORDINATE: $x = 1.00$ $L = 3.20$

m

LOADS:

Governing Load Case: 166 COMB146 (1+2)*1.35+(5+12)*1.50+3*0.75

MATERIAL:

S 275 (S 275) $f_y = 275.00$ MPa

SECTION PARAMETERS: UPN 240

$h=240$ mm	$gM0=1.00$	$gM1=1.10$	
$b=85$ mm	$A_y=2424$ mm ²	$A_z=2293$ mm ²	$A_x=4210$ mm ²
$tw=10$ mm	$I_y=35980300$ mm ⁴	$I_z=2475280$ mm ⁴	$I_x=182400$ mm ⁴
$tf=13$ mm	$W_{ply}=357597$ mm ³	$W_{plz}=76152$ mm ³	

INTERNAL FORCES AND CAPACITIES:

$N_{Ed} = 1.67$ kN	$M_{y,Ed} = 35.17$ kN*m	$M_{z,Ed} = -1.15$ kN*m	$V_{y,Ed} = 3.90$ kN
$N_{c,Rd} = 1157.88$ kN	$M_{y,Ed,max} = 35.17$ kN*m	$M_{z,Ed,max} = -3.76$ kN*m	$V_{y,T,Rd} = 384.61$ kN
$N_{b,Rd} = 324.28$ kN	$M_{y,c,Rd} = 98.34$ kN*m	$M_{z,c,Rd} = 20.94$ kN*m	$V_{z,Ed} = 18.09$ kN
	$MN_{y,Rd} = 98.34$ kN*m	$MN_{z,Rd} = 20.94$ kN*m	$V_{z,T,Rd} = 363.83$ kN
	$M_{b,Rd} = 55.97$ kN*m		$T_{t,Ed} = -0.00$ kN*m
			Class of section = 1

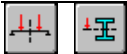

LATERAL BUCKLING PARAMETERS:

$z = 0.00$	$M_{cr} = 115.98$ kN*m	Curve,LT - d	$X_{LT} = 0.61$
$L_{cr,upp}=3.20$ m	$\lambda_{m,LT} = 0.92$	$f_{i,LT} = 1.02$	$X_{LT,mod} = 0.63$

BUCKLING PARAMETERS:



About y axis:

$L_y = 3.20$ m	$\lambda_{m,y} = 0.40$
$L_{cr,y} = 3.20$ m	$X_y = 0.90$
$\lambda_{my} = 34.62$	$k_{yy} = 1.01$



About z axis:

$L_z = 3.20$ m	$\lambda_{m,z} = 1.52$
$L_{cr,z} = 3.20$ m	$X_z = 0.31$
$\lambda_{mz} = 131.98$	$k_{yz} = 0.92$

Torsional buckling:

Curve,T=c	$\alpha_{T,c} = 0.49$
$L_t = 3.20$ m	$f_{i,T} = 0.97$
$N_{cr,T} = 1810.25$ kN	$X_{T,c} = 0.66$
$\lambda_{m,T} = 0.80$	$N_{b,T,Rd} = 697.15$ kN

Flexural-torsional buckling

Curve,TF=c	$\alpha_{TF,c} = 0.49$
$N_{cr,y} = 7282.56$ kN	$f_{i,TF} = 0.99$
$N_{cr,TF} = 1700.95$ kN	$X_{TF,c} = 0.65$
$\lambda_{m,TF} = 0.83$	$N_{b,TF,Rd} = 680.44$ kN

VERIFICATION FORMULAS:

Section strength check:

$$N_{Ed}/N_{c,Rd} = 0.00 < 1.00 \quad (6.2.4.(1))$$

$$M_{y,Ed}/M_{N,y,Rd} = 0.36 < 1.00 \quad (6.2.9.1.(2))$$

$$M_{z,Ed}/M_{N,z,Rd} = 0.05 < 1.00 \quad (6.2.9.1.(2))$$

$$(M_{y,Ed}/M_{N,y,Rd})^{1.00} + (M_{z,Ed}/M_{N,z,Rd})^{1.00} = 0.41 < 1.00 \quad (6.2.9.1.(6))$$

$$V_{y,Ed}/V_{y,T,Rd} = 0.01 < 1.00 \quad (6.2.6-7)$$

$$V_{z,Ed}/V_{z,T,Rd} = 0.05 < 1.00 \quad (6.2.6-7)$$

$$\tau_{y,Ed}/(f_y/(\sqrt{3} \cdot gM0)) = 0.00 < 1.00 \quad (6.2.6)$$

$$\tau_{z,Ed}/(f_y/(\sqrt{3} \cdot gM0)) = 0.00 < 1.00 \quad (6.2.6)$$

Global stability check of member:

$$\lambda_{m,y} = 34.62 < \lambda_{m,max} = 210.00 \quad \lambda_{m,z} = 131.98 < \lambda_{m,max} = 210.00 \quad \text{STABLE}$$

$$N_{Ed}/\min(N_{b,Rd}, N_{b,T,Rd}, N_{b,TF,Rd}) = 0.01 < 1.00 \quad (6.3.1)$$

$$M_{y,Ed,max}/M_{b,Rd} = 0.63 < 1.00 \quad (6.3.2.1.(1))$$

$$N_{Ed}/(X_y \cdot N_{Rk}/gM1) + k_{yy} \cdot M_{y,Ed,max}/(X_{LT} \cdot M_{y,Rk}/gM1) + k_{yz} \cdot M_{z,Ed,max}/(M_{z,Rk}/gM1) = 0.82 < 1.00 \quad (6.3.3.(4))$$

$$N_{Ed}/(X_z \cdot N_{Rk}/gM1) + k_{zy} \cdot M_{y,Ed,max}/(X_{LT} \cdot M_{y,Rk}/gM1) + k_{zz} \cdot M_{z,Ed,max}/(M_{z,Rk}/gM1) = 0.54 < 1.00 \quad (6.3.3.(4))$$

LIMIT DISPLACEMENTS**Deflections (LOCAL SYSTEM):**

$u_y = 1 \text{ mm} < u_{y \text{ max}} = L/200.00 = 16 \text{ mm}$ Verified

Governing Load Case: 465 COMB446 (1+2+6+13)*1.00+4*0.50

$u_z = 1 \text{ mm} < u_{z \text{ max}} = L/200.00 = 16 \text{ mm}$ Verified

Governing Load Case: 404 COMB384 (1+2+5+12)*1.00+3*0.50

$u_{\text{inst},y} = 0 \text{ mm} < u_{\text{inst,max},y} = L/250.00 = 13 \text{ mm}$ Verified

Governing Load Case: 0.5*4 + 1*6 + 1*13

$u_{\text{inst},z} = 1 \text{ mm} < u_{\text{inst,max},z} = L/250.00 = 13 \text{ mm}$ Verified

Governing Load Case: 0.5*3 + 1*5 + 1*12



Displacements (GLOBAL SYSTEM): Not analyzed

Section OK !!!

7.14. Horizontalni nosači obloge (uzdužni)

Na Slici 52. prikazan je položaj mjerodavnog uzdužnog horizontalnog nosača obloge za dimenzioniranje, te vrijednosti na dijagramima za karakterističnu kombinaciju 202 (COMB182)

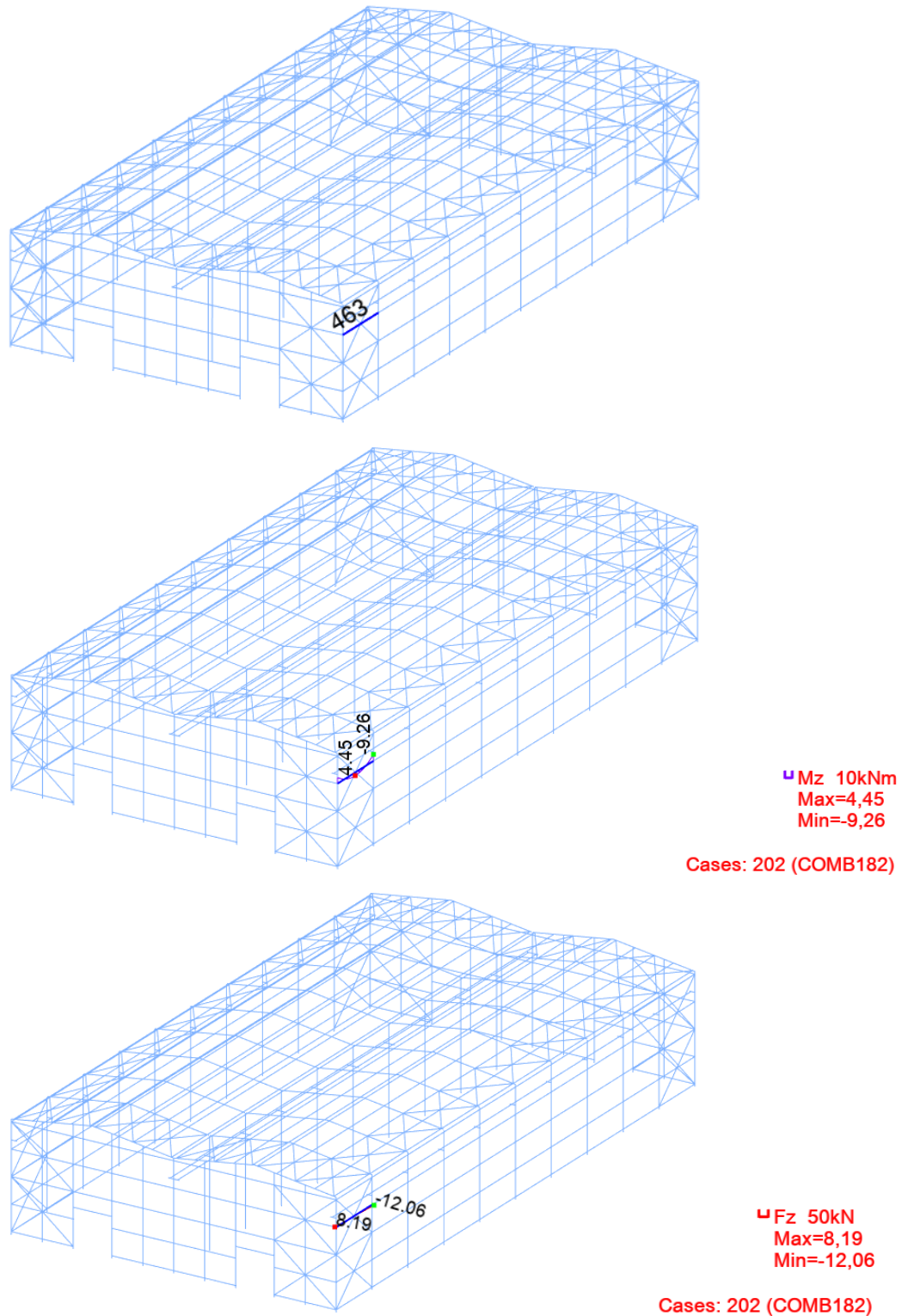

Slika 52. Položaj i vrijednosti dijagrama na horizontalnom uzdužnom nosaču obloge mjerodavnom za dimenzioniranje [izradio autor]

STEEL DESIGN

CODE: EN 1993-1:2005/A1:2014, Eurocode 3: Design of steel structures.

ANALYSIS TYPE: Member Verification

CODE GROUP:

MEMBER: 463

POINT: 1

COORDINATE: x = 0.00 L = 0.00

m

LOADS:

Governing Load Case: 202 COMB182 (1+2)*1.35+(8+12)*1.50+3*0.75

MATERIAL:

S 275 (S 275) $f_y = 275.00$ MPa



SECTION PARAMETERS: UPN 240

h=240 mm	gM0=1.00	gM1=1.10	
b=85 mm	Ay=2424 mm ²	Az=2293 mm ²	Ax=4210 mm ²
tw=10 mm	Iy=35980300 mm ⁴	Iz=2475280 mm ⁴	Ix=182400 mm ⁴
tf=13 mm	Wply=357597 mm ³	Wplz=76152 mm ³	

INTERNAL FORCES AND CAPACITIES:

N,Ed = 0.01 kN	My,Ed = 3.97 kN*m	Mz,Ed = -8.39 kN*m	Vy,Ed = -8.70 kN
Nc,Rd = 1157.88 kN	My,Ed,max = 13.89 kN*m	Mz,Ed,max = -9.26 kN*m	Vy,T,Rd = 384.35 kN
Nb,Rd = 1052.62 kN	My,c,Rd = 98.34 kN*m	Mz,c,Rd = 20.94 kN*m	Vz,Ed = 8.19 kN
	MN,y,Rd = 98.34 kN*m	MN,z,Rd = 20.94 kN*m	Vz,T,Rd = 363.66 kN
	Mb,Rd = 35.86 kN*m		Tt,Ed = 0.01 kN*m
			Class of section = 1



LATERAL BUCKLING PARAMETERS:

z = 0.00	Mcr = 54.89 kN*m	Curve,LT - d	XLT = 0.40
Lcr,upp=6.00 m	Lam_LT = 1.34	fi,LT = 1.53	XLT,mod = 0.40

BUCKLING PARAMETERS:



About y axis:

$$k_{yy} = 1.00$$



About z axis:

$$k_{zz} = 1.00$$

VERIFICATION FORMULAS:

Section strength check:

$$N_{Ed}/N_{c,Rd} = 0.00 < 1.00 \quad (6.2.4.(1))$$

$$M_{y,Ed}/M_{N,y,Rd} = 0.04 < 1.00 \quad (6.2.9.1.(2))$$

$$M_{z,Ed}/M_{N,z,Rd} = 0.40 < 1.00 \quad (6.2.9.1.(2))$$

$$(M_{y,Ed}/M_{N,y,Rd})^{1.00} + (M_{z,Ed}/M_{N,z,Rd})^{1.00} = 0.44 < 1.00 \quad (6.2.9.1.(6))$$

$$V_{y,Ed}/V_{y,T,Rd} = 0.02 < 1.00 \quad (6.2.6-7)$$

$$V_{z,Ed}/V_{z,T,Rd} = 0.02 < 1.00 \quad (6.2.6-7)$$

$$\tau_{y,t,Ed}/(f_y/(\sqrt{3} \cdot gM0)) = 0.00 < 1.00 \quad (6.2.6)$$

$$\tau_{z,t,Ed}/(f_y/(\sqrt{3} \cdot gM0)) = 0.00 < 1.00 \quad (6.2.6)$$

Global stability check of member:

$$M_{y,Ed,max}/M_{b,Rd} = 0.39 < 1.00 \quad (6.3.2.1.(1))$$

$$N_{Ed}/(X_y \cdot N_{Rk}/gM1) + k_{yy} \cdot M_{y,Ed,max}/(XLT \cdot M_{y,Rk}/gM1) + k_{yz} \cdot M_{z,Ed,max}/(M_{z,Rk}/gM1) = 0.87 < 1.00 \quad (6.3.3.(4))$$

$$N_{Ed}/(X_z \cdot N_{Rk}/gM1) + k_{zy} \cdot M_{y,Ed,max}/(XLT \cdot M_{y,Rk}/gM1) + k_{zz} \cdot M_{z,Ed,max}/(M_{z,Rk}/gM1) = 0.87 < 1.00 \quad (6.3.3.(4))$$

LIMIT DISPLACEMENTS

**Deflections (LOCAL SYSTEM):**

$u_y = 15 \text{ mm} < u_{y \text{ max}} = L/200.00 = 30 \text{ mm}$ Verified

Governing Load Case: 401 COMB381 (1+2+5+9)*1.00+3*0.50

$u_z = 5 \text{ mm} < u_{z \text{ max}} = L/200.00 = 30 \text{ mm}$ Verified

Governing Load Case: 8 Vjetar 4

$u_{\text{inst},y} = 0 \text{ mm} < u_{\text{inst,max},y} = L/250.00 = 24 \text{ mm}$ Verified

Governing Load Case: 0.5*3 + 1*8 + 1*17

$u_{\text{inst},z} = 5 \text{ mm} < u_{\text{inst,max},z} = L/250.00 = 24 \text{ mm}$ Verified

Governing Load Case: 1*8



Displacements (GLOBAL SYSTEM): Not analyzed

Section OK !!!

7.15. Konzole

Na Slici 53. prikazan je položaj mjerodavne konzole za dimenzioniranje, te vrijednosti na dijagramima za karakterističnu kombinaciju 234 (COMB214)

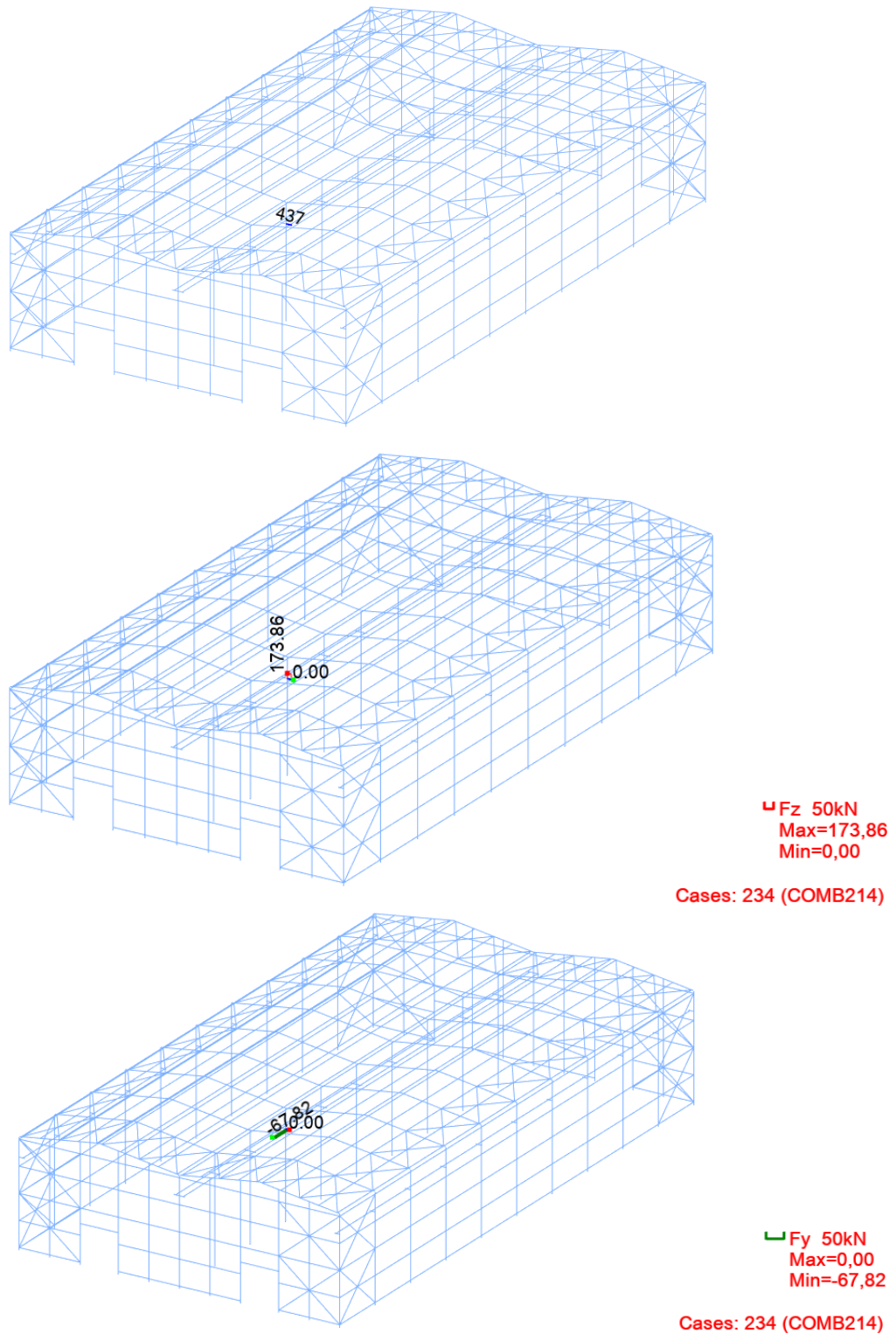

Slika 53. Položaj i vrijednosti dijagrama na konzoli mjerodavnoj za dimenzioniranje [izradio autor]

STEEL DESIGN

CODE: EN 1993-1:2005/A1:2014, Eurocode 3: Design of steel structures.

ANALYSIS TYPE: Member Verification

CODE GROUP:

MEMBER: 437

POINT: 3

COORDINATE: $x = 0.67 L = 0.40$

m

LOADS:

Governing Load Case: 234 COMB214 (1+2)*1.35+(6+20)*1.50+4*0.75

MATERIAL:

S 275 (S 275) $f_y = 275.00$ MPa



SECTION PARAMETERS: IPE 300

$h=300$ mm	$gM0=1.00$	$gM1=1.10$	
$b=150$ mm	$A_y=3616$ mm ²	$A_z=2568$ mm ²	$A_x=5381$ mm ²
$t_w=7$ mm	$I_y=83561100$ mm ⁴	$I_z=6037790$ mm ⁴	$I_x=194700$ mm ⁴
$t_f=11$ mm	$W_{ply}=628399$ mm ³	$W_{plz}=125222$ mm ³	

INTERNAL FORCES AND CAPACITIES:

$N_{,Ed} = 12.36$ kN	$M_{y,Ed} = 1.94$ kN*m	$M_{z,Ed} = 27.54$ kN*m	$V_{y,Ed} = -67.82$ kN
$N_{c,Rd} = 1479.83$ kN	$M_{y,pl,Rd} = 172.81$ kN*m	$M_{z,pl,Rd} = 34.44$ kN*m	$V_{y,T,Rd} = 557.60$ kN
$N_{b,Rd} = 1345.30$ kN	$M_{y,c,Rd} = 172.81$ kN*m	$M_{z,c,Rd} = 34.44$ kN*m	$V_{z,Ed} = 173.64$ kN
	$MN_{,y,Rd} = 172.81$ kN*m	$MN_{,z,Rd} = 34.44$ kN*m	$V_{z,T,Rd} = 400.00$ kN
			$T_{t,Ed} = -0.21$ kN*m
			Class of section = 1



LATERAL BUCKLING PARAMETERS:

BUCKLING PARAMETERS:



About y axis:



About z axis:

VERIFICATION FORMULAS:

Section strength check:

$$N_{,Ed}/N_{c,Rd} = 0.01 < 1.00 \quad (6.2.4.(1))$$

$$M_{y,Ed}/MN_{,y,Rd} = 0.01 < 1.00 \quad (6.2.9.1.(2))$$

$$M_{z,Ed}/MN_{,z,Rd} = 0.80 < 1.00 \quad (6.2.9.1.(2))$$

$$(M_{y,Ed}/MN_{,y,Rd})^{2.00} + (M_{z,Ed}/MN_{,z,Rd})^{1.00} = 0.80 < 1.00 \quad (6.2.9.1.(6))$$

$$V_{y,Ed}/V_{y,T,Rd} = 0.12 < 1.00 \quad (6.2.6-7)$$

$$V_{z,Ed}/V_{z,T,Rd} = 0.43 < 1.00 \quad (6.2.6-7)$$

$$\tau_{u,y,Ed}/(f_y/(\sqrt{3})gM0) = 0.07 < 1.00 \quad (6.2.6)$$

$$\tau_{u,z,Ed}/(f_y/(\sqrt{3})gM0) = 0.05 < 1.00 \quad (6.2.6)$$

Section OK !!!

7.16. Kranska staza

Na Slici 54. prikazan je položaj mjerodavne kranske staze za dimenzioniranje, te vrijednosti na dijagramima za karakterističnu kombinaciju 223 (COMB203)

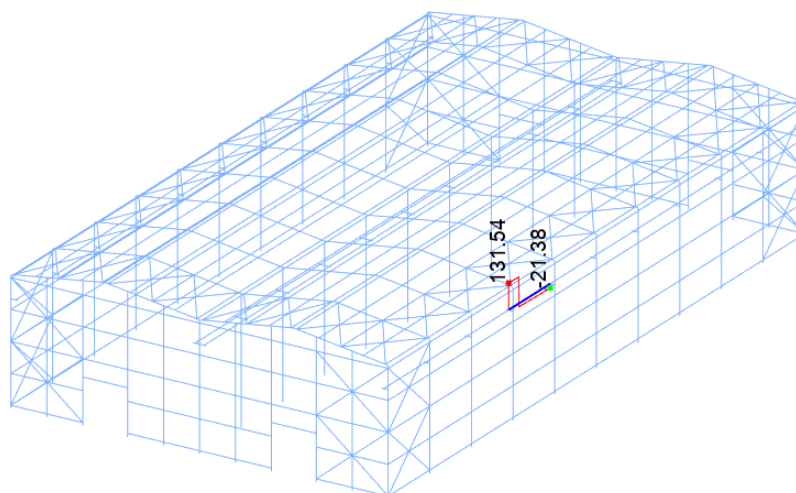
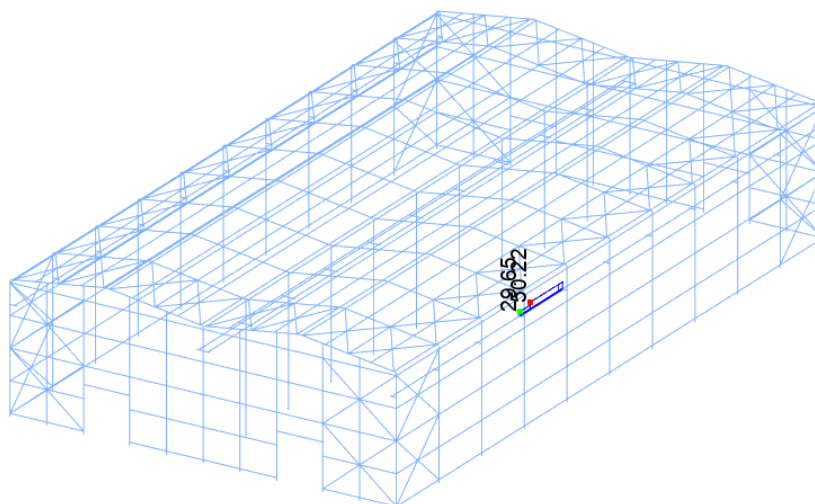
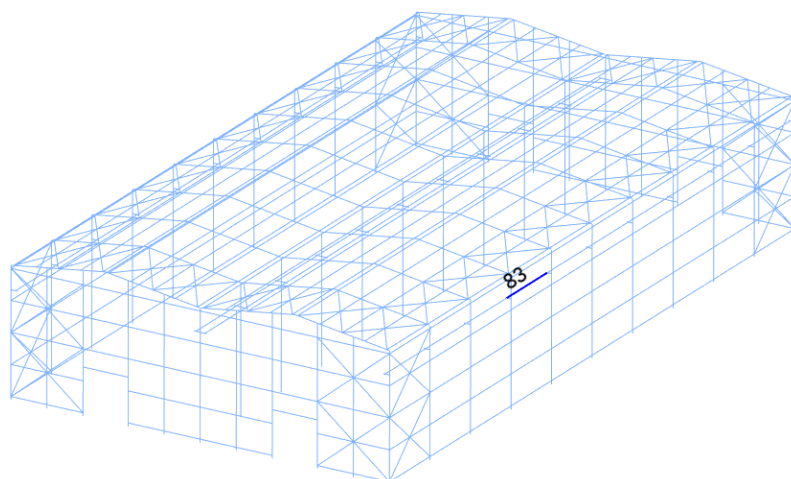

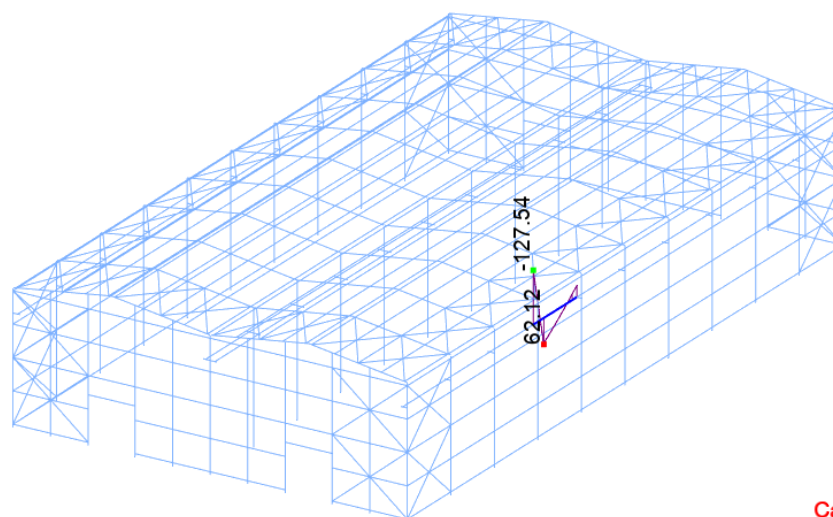

Slika 54. Položaj i vrijednosti dijagrama na kranskoj stazi mjerodavnoj za dimenzioniranje
[izradio autor]

STEEL DESIGN

CODE: EN 1993-1:2005/A1:2014, Eurocode 3: Design of steel structures.

ANALYSIS TYPE: Member Verification

CODE GROUP:

MEMBER: 83
m

POINT: 3

COORDINATE: x = 1.00 L = 6.00

LOADS:

Governing Load Case: 223 COMB203 (1+2)*1.35+(6+9)*1.50+4*0.75

MATERIAL:

S 275 (S 275) $f_y = 275.00$ MPa



SECTION PARAMETERS: HEA 280

h=270 mm	gM0=1.00	gM1=1.10	
b=280 mm	Ay=8158 mm ²	Az=3174 mm ²	Ax=9726 mm ²
tw=8 mm	Iy=136733000 mm ⁴	Iz=47626400 mm ⁴	Ix=565000 mm ⁴
tf=13 mm	Wply=1112320 mm ³	Wplz=518143 mm ³	

INTERNAL FORCES AND CAPACITIES:

N,Ed = 50.22 kN	My,Ed = -27.47 kN*m	Mz,Ed = 6.12 kN*m	Vy,Ed = -3.33 kN
Nc,Rd = 2674.77 kN	My,Ed,max = -127.54 kN*m		Mz,Ed,max = -8.86 kN*m
	Vy,T,Rd = 1264.02 kN		
Nb,Rd = 1330.40 kN	My,c,Rd = 305.89 kN*m	Mz,c,Rd = 142.49 kN*m	Vz,Ed = -21.38 kN
	MN,y,Rd = 305.89 kN*m	MN,z,Rd = 142.49 kN*m	Vz,T,Rd = 496.55 kN
	Mb,Rd = 244.04 kN*m		Tt,Ed = -0.41 kN*m
			Class of section = 2



LATERAL BUCKLING PARAMETERS:

z = 0.00	Mcr = 565.18 kN*m	Curve,LT - b	XLT = 0.85
Lcr,low=6.00 m	Lam_LT = 0.74	fi,LT = 0.76	XLT,mod = 0.88

BUCKLING PARAMETERS:

About y axis:

Ly = 6.00 m Lam_y = 0.58
 Lcr,y = 6.00 m Xy = 0.85
 Lamy = 50.60 kyy = 1.02



About z axis:

Lz = 6.00 m Lam_z = 0.99
 Lcr,z = 6.00 m Xz = 0.55
 Lamz = 85.74 kyz = 0.94

Torsional buckling:

Curve,T=c alfa,T=0.49
 Lt=6.00 m fi,T=0.91
 Ncr,T=4796.28 kN X,T=0.70
 Lam_T=0.75 Nb,T,Rd=1691.32 kN

Flexural-torsional buckling

Curve,TF=c alfa,TF=0.49
 Ncr,y=7872.09 kN fi,TF=0.76
 Ncr,TF=7872.09 kN X,TF=0.80
 Lam_TF=0.58 Nb,TF,Rd=1934.27 kN

VERIFICATION FORMULAS:**Section strength check:**

$N_{Ed}/N_{c,Rd} = 0.02 < 1.00$ (6.2.4.(1))
 $M_{y,Ed}/M_{N,y,Rd} = 0.09 < 1.00$ (6.2.9.1.(2))
 $M_{z,Ed}/M_{N,z,Rd} = 0.04 < 1.00$ (6.2.9.1.(2))
 $(M_{y,Ed}/M_{N,y,Rd})^2 + (M_{z,Ed}/M_{N,z,Rd})^1 = 0.05 < 1.00$ (6.2.9.1.(6))
 $V_{y,Ed}/V_{y,T,Rd} = 0.00 < 1.00$ (6.2.6-7)
 $V_{z,Ed}/V_{z,T,Rd} = 0.04 < 1.00$ (6.2.6-7)
 $\tau_{ty,Ed}/(f_y/(\sqrt{3} \cdot g_{M0})) = 0.06 < 1.00$ (6.2.6)
 $\tau_{tz,Ed}/(f_y/(\sqrt{3} \cdot g_{M0})) = 0.04 < 1.00$ (6.2.6)

Global stability check of member:

$\lambda_{y,Ed} = 50.60 < \lambda_{y,max} = 210.00$ $\lambda_{z,Ed} = 85.74 < \lambda_{z,max} = 210.00$ STABLE
 $N_{Ed}/\min(N_{b,Rd}, N_{b,T,Rd}, N_{b,TF,Rd}) = 0.04 < 1.00$ (6.3.1)
 $M_{y,Ed,max}/M_{b,Rd} = 0.52 < 1.00$ (6.3.2.1.(1))
 $N_{Ed}/(X_y \cdot N_{Rk}/g_{M1}) + k_{yy} \cdot M_{y,Ed,max}/(X_{LT} \cdot M_{y,Rk}/g_{M1}) + k_{yz} \cdot M_{z,Ed,max}/(M_{z,Rk}/g_{M1}) = 0.62 < 1.00$
 (6.3.3.(4))
 $N_{Ed}/(X_z \cdot N_{Rk}/g_{M1}) + k_{zy} \cdot M_{y,Ed,max}/(X_{LT} \cdot M_{y,Rk}/g_{M1}) + k_{zz} \cdot M_{z,Ed,max}/(M_{z,Rk}/g_{M1}) = 0.38 < 1.00$
 (6.3.3.(4))

LIMIT DISPLACEMENTS**Deflections (LOCAL SYSTEM):**

uy = 1 mm < uy max = L/200.00 = 30 mm Verified
Governing Load Case: 473 COMB454 (1+2+7+9)*1.00+4*0.50
 uz = 4 mm < uz max = L/200.00 = 30 mm Verified
Governing Load Case: 17 Kran 9
 u inst,y = 1 mm < u inst,max,y = L/250.00 = 24 mm Verified
Governing Load Case: 0.5*4 + 1*7 + 1*17
 u inst,z = 4 mm < u inst,max,z = L/250.00 = 24 mm Verified
Governing Load Case: 0.5*3 + 1*5 + 1*17

**Displacements (GLOBAL SYSTEM):**

vx = 4 mm < vx max = L/150.00 = 40 mm Verified
Governing Load Case: 276 COMB256 (1+2+6)*1.00+4*0.50
 vy = 1 mm < vy max = L/150.00 = 40 mm Verified
Governing Load Case: 469 COMB450 (1+2+6+17)*1.00+4*0.50

Section OK !!!

Odabrani profili elemenata prikazani su u Tablici 22. :

Tablica 22. Odabrani profili elemenata [izradio autor]

Element	Profil	Materijal
Vanjski stupovi	HEA 340	S 275
Vanjski zabatni stupovi	IPE 330	S 275
Unutarnji stupovi	HEA 340	S 275
Unutarnji zabatni stupovi	IPE 330	S 275
Gredni nosači	HEA 340	S 275
Gredni zabatni nosači	IPE 330	S 275
Podrožnice	IPE 270	S 275
Zabatni stupovi	IPE 330	S 275
Krovni uzdužni vezovi	Okrugli puni profil 25 mm	S 275
Krovni poprečni vezovi	Okrugli puni profil 25 mm	S 275
Vertikalni uzdužni vezovi	Okrugli puni profil 25 mm	S 275
Vertikalni poprečni vezovi	Okrugli puni profil 25 mm	S 275
Horizontalni zabatni nosači obloge	UPN 240	S 275
Horizontalni uzdužni nosači obloge	UPN 240	S 275
Konzole	IPE 300	S 275
Kranska staza	HEA 280	S 275

8. DIMENZIONIRANJE PRIKLJUČAKA

8.1. Priključak stupa i grednog nosača



Autodesk Robot Structural Analysis Professional 2022

Design of fixed beam-to-column connection

EN 1993-1-8:2005/AC:2009



Ratio
0,77

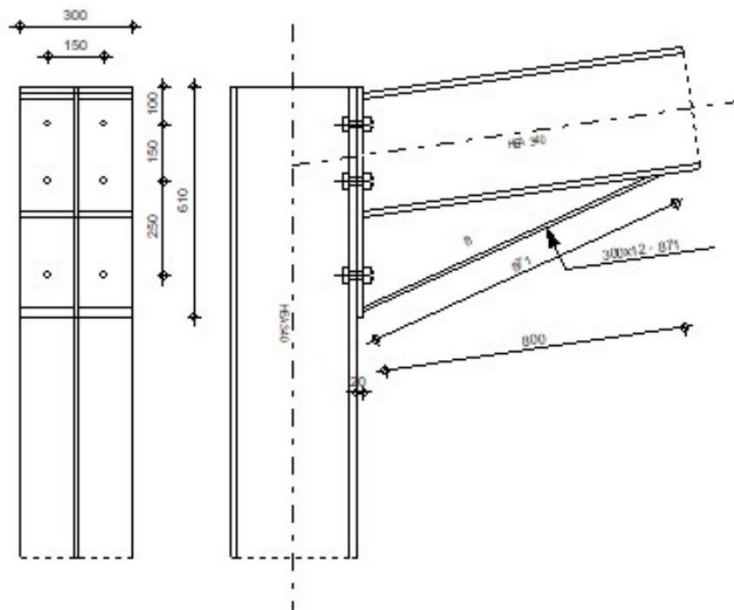

General

Connection no.: 1
 Connection name: Priključak stupa i nosača
 Structure node: 30
 Structure members: 24, 27

Geometry

Column

Section: HEA 340
 Member no.: 24
 a = -90,0 [Deg] Inclination angle
 h_c = 330 [mm] Height of column section
 b_{fc} = 300 [mm] Width of column section
 t_{wc} = 10 [mm] Thickness of the web of column section

Section: HEA 340

$t_{fc} = 16$ [mm] Thickness of the flange of column section

$r_c = 27$ [mm] Radius of column section fillet

$A_c = 13347$ [mm²] Cross-sectional area of a column

$I_{xc} = 276931000$ [mm⁴] Moment of inertia of the column section

Material: S 275

$f_{yc} = 275,00$ [MPa] Resistance

Beam

Section: HEA 340

Member no.: 27

$a = 8,1$ [Deg] Inclination angle

$h_b = 330$ [mm] Height of beam section

$b_f = 300$ [mm] Width of beam section

$t_{wb} = 10$ [mm] Thickness of the web of beam section

$t_{fb} = 16$ [mm] Thickness of the flange of beam section

$r_b = 27$ [mm] Radius of beam section fillet

$r_b = 27$ [mm] Radius of beam section fillet

$A_b = 13347$ [mm²] Cross-sectional area of a beam

$I_{xb} = 276931000$ [mm⁴] Moment of inertia of the beam section

Material: S 275

$f_{yb} = 275,00$ [MPa] Resistance

Bolts

The shear plane passes through the UNTHREADED portion of the bolt.

$d = 20$ [mm] Bolt diameter

Class = 8.8 Bolt class

$F_{tRd} = 141,12$ [kN] Tensile resistance of a bolt

$n_h = 2$ Number of bolt columns

$n_v = 3$ Number of bolt rows

$h_1 = 100$ [mm] Distance between first bolt and upper edge of front plate

Horizontal spacing $e_i = 150$ [mm]

Vertical spacing $p_i = 150;250$ [mm]

Plate

$h_p =$	610	[mm]	Plate height
$b_p =$	300	[mm]	Plate width
$t_p =$	20	[mm]	Plate thickness
Material:	S 275		

$f_{yp} =$	275,00	[MPa]	Resistance
------------	--------	-------	------------

Lower stiffener

$w_d =$	300	[mm]	Plate width
$t_{rd} =$	12	[mm]	Flange thickness
$h_d =$	250	[mm]	Plate height
$t_{wd} =$	8	[mm]	Web thickness
$l_d =$	800	[mm]	Plate length
$\alpha =$	24,6	[Deg]	Inclination angle

Material: S 355

$f_{ybu} =$	355,00	[MPa]	Resistance
-------------	--------	-------	------------

Fillet welds

$a_w =$	6	[mm]	Web weld
$a_f =$	7	[mm]	Flange weld
$a_{fd} =$	5	[mm]	Horizontal weld

Material factors

$g_{M0} =$	1,00	Partial safety factor	[2.2]
$g_{M1} =$	1,00	Partial safety factor	[2.2]
$g_{M2} =$	1,25	Partial safety factor	[2.2]
$g_{M3} =$	1,25	Partial safety factor	[2.2]

Loads

Ultimate limit state

Case: 30: COMB10 (1+2)*1.35+4*1.50+6*0.90

$M_{b1,Ed} =$	146,98	[kN*m]	Bending moment in the right beam
$V_{b1,Ed} =$	81,01	[kN]	Shear force in the right beam
$N_{b1,Ed} =$	-10,88	[kN]	Axial force in the right beam
$M_{c1,Ed} =$	146,98	[kN*m]	Bending moment in the lower column

$M_{b1,Ed} = 146,98$ [kN*m] Bending moment in the right beam

$V_{c1,Ed} = 10,88$ [kN] Shear force in the lower column

$N_{c1,Ed} = -81,01$ [kN] Axial force in the lower column

Results

Beam resistances

COMPRESSION

$A_b = 13347$ [mm²] Area EN1993-1-1:[6.2.4]

$N_{cb,Rd} = A_b f_{yb} / g_{M0}$

$N_{cb,Rd} = 3670,51$ [kN] Design compressive resistance of the section EN1993-1-1:[6.2.4]

SHEAR

$A_{vb} = 6495$ [mm²] Shear area EN1993-1-1:[6.2.6.(3)]

$V_{cb,Rd} = A_{vb} (f_{yb} / \sqrt{3}) / g_{M0}$

$V_{cb,Rd} = 1031,23$ [kN] Design sectional resistance for shear EN1993-1-1:[6.2.6.(2)]

$V_{b1,Ed} / V_{cb,Rd} \leq 1,0$	$0,08 < 1,00$	verified	(0,08)
----------------------------------	---------------	----------	--------

BENDING - PLASTIC MOMENT (WITHOUT BRACKETS)

$W_{plb} = 1850620$ [mm³] Plastic section modulus EN1993-1-1:[6.2.5.(2)]

$M_{b,pl,Rd} = W_{plb} f_{yb} / g_{M0}$

$M_{b,pl,Rd} = 508,9$ [kN*m] Plastic resistance of the section for bending (without stiffeners) EN1993-1-1:[6.2.5.(2)]

BENDING ON THE CONTACT SURFACE WITH PLATE OR CONNECTED ELEMENT

$W_{pl} = 3246700$ [mm³] Plastic section modulus EN1993-1-1:[6.2.5]

$M_{cb,Rd} = W_{pl} f_{yb} / g_{M0}$

$M_{cb,Rd} = 892,84$ [kN*m] Design resistance of the section for bending EN1993-1-1:[6.2.5]

FLANGE AND WEB - COMPRESSION

$M_{cb,Rd} = 892,84$ [kN*m] Design resistance of the section for bending EN1993-1-1:[6.2.5]

$h_f = 568$ [mm] Distance between the centroids of flanges [6.2.6.7.(1)]

$F_{c,fb,Rd} = M_{cb,Rd} / h_f$

$F_{c,fb,Rd} = 1570,76$ [kN] Resistance of the compressed flange and web [6.2.6.7.(1)]

WEB OR BRACKET FLANGE - COMPRESSION - LEVEL OF THE BEAM BOTTOM FLANGE

Bearing:

$b =$	8,1 [Deg]	Angle between the front plate and the beam	
$g =$	24,6 [Deg]	Inclination angle of the bracket plate	
$b_{eff,c,wb} =$	280 [mm]	Effective width of the web for compression	[6.2.6.2.(1)]
$A_{vb} =$	4495 [mm ²]	Shear area	EN1993-1-1:[6.2.6.(3)]
$w =$	0,83	Reduction factor for interaction with shear	[6.2.6.2.(1)]
$\sigma_{com,Ed} =$	65,30 [MPa]	Maximum compressive stress in web	[6.2.6.2.(2)]
$k_{wc} =$	1,00	Reduction factor conditioned by compressive stresses	[6.2.6.2.(2)]

$$F_{c,wb,Rd1} = [w k_{wc} b_{eff,c,wb} t_{wb} f_{yb} / \sigma_{M0}] \cos(g) / \sin(g - b)$$

$$F_{c,wb,Rd1} = 1938,25 \text{ [kN]} \quad \text{Beam web resistance} \quad [6.2.6.2.(1)]$$

Buckling:

$$d_{wb} = 243 \text{ [mm]} \quad \text{Height of compressed web} \quad [6.2.6.2.(1)]$$

$$l_p = 0,93 \quad \text{Plate slenderness of an element} \quad [6.2.6.2.(1)]$$

$$r = 0,85 \quad \text{Reduction factor for element buckling} \quad [6.2.6.2.(1)]$$

$$F_{c,wb,Rd2} = [w k_{wc} r b_{eff,c,wb} t_{wb} f_{yb} / \sigma_{M1}] \cos(g) / \sin(g - b)$$

$$F_{c,wb,Rd2} = 1641,98 \text{ [kN]} \quad \text{Beam web resistance} \quad [6.2.6.2.(1)]$$

Final resistance:

$$F_{c,wb,Rd,low} = \text{Min} (F_{c,wb,Rd1}, F_{c,wb,Rd2})$$

$$F_{c,wb,Rd,low} = 1641,98 \text{ [kN]} \quad \text{Beam web resistance} \quad [6.2.6.2.(1)]$$

Column resistances

WEB PANEL - SHEAR

$$M_{b1,Ed} = 146,98 \text{ [kN*m]} \quad \text{Bending moment (right beam)} \quad [5.3.(3)]$$

$$M_{b2,Ed} = 0,00 \text{ [kN*m]} \quad \text{Bending moment (left beam)} \quad [5.3.(3)]$$

$$V_{c1,Ed} = 10,88 \text{ [kN]} \quad \text{Shear force (lower column)} \quad [5.3.(3)]$$

$$V_{c2,Ed} = 0,00 \text{ [kN]} \quad \text{Shear force (upper column)} \quad [5.3.(3)]$$

$$z = 417 \text{ [mm]} \quad \text{Lever arm} \quad [6.2.5]$$

$$V_{wp,Ed} = (M_{b1,Ed} - M_{b2,Ed}) / z - (V_{c1,Ed} - V_{c2,Ed}) / 2$$

$$V_{wp,Ed} = 347,23 \text{ [kN]} \quad \text{Shear force acting on the web panel} \quad [5.3.(3)]$$

$$A_{vs} = 4495 \text{ [mm}^2\text{]} \quad \text{Shear area of the column web} \quad \text{EN1993-1-1:[6.2.6.(3)]}$$

$$A_{vc} = 4495 \text{ [mm}^2\text{]} \quad \text{Shear area} \quad \text{EN1993-1-1:[6.2.6.(3)]}$$

$$V_{wp,Rd} = 0.9 * (f_{y,wc} * A_{vc} + f_{y,wp} * A_{vp} + f_{ys} * A_{vd}) / (\sqrt{3} \sigma_{M0})$$

$$V_{wp,Rd} = 642,32 \text{ [kN]} \quad \text{Resistance of the column web panel for shear} \quad [6.2.6.1]$$

$$V_{wp,Ed} / V_{wp,Rd} \leq 1,0 \quad 0,54 < 1,00 \quad \text{verified} \quad (0,54)$$

WEB - TRANSVERSE COMPRESSION - LEVEL OF THE BEAM BOTTOM FLANGE

Bearing:

$t_{wc} = 10$ [mm]	Effective thickness of the column web	[6.2.6.2.(6)]
$b_{eff,c,wc} = 291$ [mm]	Effective width of the web for compression	[6.2.6.2.(1)]
$A_{vc} = 4495$ [mm ²]	Shear area	EN1993-1-1:[6.2.6.(3)]
$w = 0,82$	Reduction factor for interaction with shear	[6.2.6.2.(1)]
$\sigma_{com,Ed} = 70,55$ [MPa]	Maximum compressive stress in web	[6.2.6.2.(2)]
$k_{wc} = 1,00$	Reduction factor conditioned by compressive stresses	[6.2.6.2.(2)]

$$F_{c,wc,Rd1} = w k_{wc} b_{eff,c,wc} t_{wc} f_{yc} / \gamma_{M0}$$

$$F_{c,wc,Rd1} = 621,74 \text{ [kN]} \quad \text{Column web resistance} \quad [6.2.6.2.(1)]$$

Buckling:

$d_{wc} = 243$ [mm]	Height of compressed web	[6.2.6.2.(1)]
$l_p = 0,94$	Plate slenderness of an element	[6.2.6.2.(1)]
$r = 0,84$	Reduction factor for element buckling	[6.2.6.2.(1)]

$$F_{c,wb,Rd2} = w k_{wc} r b_{eff,c,wc} t_{wc} f_{yc} / \gamma_{M1}$$

$$F_{c,wb,Rd2} = 519,38 \text{ [kN]} \quad \text{Column web resistance} \quad [6.2.6.2.(1)]$$

Final resistance:

$$F_{c,wc,Rd,low} = \text{Min} (F_{c,wc,Rd1}, F_{c,wb,Rd2})$$

$$F_{c,wc,Rd} = 519,38 \text{ [kN]} \quad \text{Column web resistance} \quad [6.2.6.2.(1)]$$

WEB - TRANSVERSE COMPRESSION - LEVEL OF THE BEAM TOP FLANGE

Bearing:

$t_{wc} = 10$ [mm]	Effective thickness of the column web	[6.2.6.2.(6)]
$b_{eff,c,wc} = 294$ [mm]	Effective width of the web for compression	[6.2.6.2.(1)]
$A_{vc} = 4495$ [mm ²]	Shear area	EN1993-1-1:[6.2.6.(3)]
$w = 0,82$	Reduction factor for interaction with shear	[6.2.6.2.(1)]
$\sigma_{com,Ed} = 70,55$ [MPa]	Maximum compressive stress in web	[6.2.6.2.(2)]
$k_{wc} = 1,00$	Reduction factor conditioned by compressive stresses	[6.2.6.2.(2)]

$$F_{c,wc,Rd1} = w k_{wc} b_{eff,c,wc} t_{wc} f_{yc} / \gamma_{M0}$$

$$F_{c,wc,Rd1} = 626,69 \text{ [kN]} \quad \text{Column web resistance} \quad [6.2.6.2.(1)]$$

Buckling:

$d_{wc} = 243$ [mm] Height of compressed web [6.2.6.2.(1)]

$l_p = 0,95$ Plate slenderness of an element [6.2.6.2.(1)]

$r = 0,83$ Reduction factor for element buckling [6.2.6.2.(1)]

$$F_{c,wb,Rd2} = w k_{wc} r b_{eff,c,wc} t_{wc} f_{yc} / \gamma_{M1}$$

$F_{c,wc,Rd2} = 521,25$ [kN] Column web resistance [6.2.6.2.(1)]

Final resistance:

$$F_{c,wc,Rd,upp} = \text{Min} (F_{c,wc,Rd1} , F_{c,wc,Rd2})$$

$F_{c,wc,Rd,upp} = 521,25$ [kN] Column web resistance [6.2.6.2.(1)]

Geometrical parameters of a connection

EFFECTIVE LENGTHS AND PARAMETERS - COLUMN FLANGE

Nr	m	m_x	e	e_x	p	$l_{eff,cp}$	$l_{eff,nc}$	$l_{eff,1}$	$l_{eff,2}$	$l_{eff,cp,g}$	$l_{eff,nc,g}$	$l_{eff,1,g}$	$l_{eff,2,g}$
1	49	-	75	-	150	306	244	244	244	303	175	175	175
2	49	-	75	-	200	306	288	288	288	300	150	150	150
3	49	-	75	-	250	306	254	254	254	403	235	235	235

EFFECTIVE LENGTHS AND PARAMETERS - FRONT PLATE

Nr	m	m_x	e	e_x	p	$l_{eff,cp}$	$l_{eff,nc}$	$l_{eff,1}$	$l_{eff,2}$	$l_{eff,cp,g}$	$l_{eff,nc,g}$	$l_{eff,1,g}$	$l_{eff,2,g}$
1	63	-	75	-	150	399	391	391	391	349	292	292	292
2	63	-	75	-	200	399	348	348	348	400	200	200	200
3	63	-	75	-	250	399	348	348	348	449	299	299	299

m – Bolt distance from the web

m_x – Bolt distance from the beam flange

e – Bolt distance from the outer edge

e_x – Bolt distance from the horizontal outer edge

p – Distance between bolts

$l_{eff,cp}$ – Effective length for a single bolt row in the circular failure mode

$l_{eff,nc}$ – Effective length for a single bolt row in the non-circular failure mode

$l_{eff,1}$ – Effective length for a single bolt row for mode 1

$l_{eff,2}$ – Effective length for a single bolt row for mode 2

$l_{eff,cp,g}$ – Effective length for a group of bolts in the circular failure mode

$l_{eff,nc,g}$ – Effective length for a group of bolts in the non-circular failure mode

$l_{eff,1,g}$ – Effective length for a group of bolts for mode 1

m – Bolt distance from the web

$l_{\text{eff},2,g}$ – Effective length for a group of bolts for mode 2

Connection resistance for compression

$$N_{j,Rd} = \text{Min} (N_{cb,Rd} / 2 F_{c,wb,Rd,low} , 2 F_{c,wc,Rd,low} , 2 F_{c,wc,Rd,upp})$$

$$N_{j,Rd} = 1038,77 \text{ [kN]} \quad \text{Connection resistance for compression} \quad [6.2]$$

$$N_{b1,Ed} / N_{j,Rd} \leq 1,0 \quad 0,01 < 1,00 \quad \text{verified} \quad (0,01)$$

Connection resistance for bending

$$F_{t,Rd} = 141,12 \text{ [kN]} \quad \text{Bolt resistance for tension} \quad [\text{Table 3.4}]$$

$$B_{p,Rd} = 320,97 \text{ [kN]} \quad \text{Punching shear resistance of a bolt} \quad [\text{Table 3.4}]$$

$F_{t,fc,Rd}$ – column flange resistance due to bending

$F_{t,wc,Rd}$ – column web resistance due to tension

$F_{t,ep,Rd}$ – resistance of the front plate due to bending

$F_{t,wb,Rd}$ – resistance of the web in tension

$$F_{t,fc,Rd} = \text{Min} (F_{T,1,fc,Rd} , F_{T,2,fc,Rd} , F_{T,3,fc,Rd}) \quad [6.2.6.4] , [\text{Tab.6.2}]$$

$$F_{t,wc,Rd} = w b_{\text{eff},t,wc} t_{wc} f_{yc} / g_{M0} \quad [6.2.6.3.(1)]$$

$$F_{t,ep,Rd} = \text{Min} (F_{T,1,ep,Rd} , F_{T,2,ep,Rd} , F_{T,3,ep,Rd}) \quad [6.2.6.5] , [\text{Tab.6.2}]$$

$$F_{t,wb,Rd} = b_{\text{eff},t,wb} t_{wb} f_{yb} / g_{M0} \quad [6.2.6.8.(1)]$$

RESISTANCE OF THE BOLT ROW NO. 1

$F_{t1,Rd,comp}$ - Formula	$F_{t1,Rd,comp}$	Component
$F_{t1,Rd} = \text{Min} (F_{t1,Rd,comp})$	240,30	Bolt row resistance
$F_{t,fc,Rd(1)} = 240,30$	240,30	Column flange - tension
$F_{t,wc,Rd(1)} = 549,80$	549,80	Column web - tension
$F_{t,ep,Rd(1)} = 282,24$	282,24	Front plate - tension
$F_{t,wb,Rd(1)} = 1022,18$	1022,18	Beam web - tension
$B_{p,Rd} = 641,94$	641,94	Bolts due to shear punching
$V_{wp,Rd}/b = 642,32$	642,32	Web panel - shear
$F_{c,wc,Rd} = 519,38$	519,38	Column web - compression
$F_{c,fb,Rd} = 1570,76$	1570,76	Beam flange - compression
$F_{c,wb,Rd} = 1641,98$	1641,98	Beam web - compression

RESISTANCE OF THE BOLT ROW NO. 2

F_{t2,Rd,comp} - Formula	F_{t2,Rd,comp}	Component
$F_{t2,Rd} = \text{Min} (F_{t2,Rd,comp})$	184,44	Bolt row resistance
$F_{t,fc,Rd(2)} = 255,41$	255,41	Column flange - tension
$F_{t,wc,Rd(2)} = 618,64$	618,64	Column web - tension
$F_{t,ep,Rd(2)} = 282,24$	282,24	Front plate - tension
$F_{t,wb,Rd(2)} = 908,10$	908,10	Beam web - tension
$B_{p,Rd} = 641,94$	641,94	Bolts due to shear punching
$V_{wp,Rd}/b - \sum 1^1 F_{tj,Rd} = 642,32 - 240,30$	402,01	Web panel - shear
$F_{c,wc,Rd} - \sum 1^1 F_{tj,Rd} = 519,38 - 240,30$	279,08	Column web - compression
$F_{c,fb,Rd} - \sum 1^1 F_{tj,Rd} = 1570,76 - 240,30$	1330,45	Beam flange - compression
$F_{c,wb,Rd} - \sum 1^1 F_{tj,Rd} = 1641,98 - 240,30$	1401,67	Beam web - compression
$F_{t,fc,Rd(2+1)} - \sum 1^1 F_{tj,Rd} = 424,74 - 240,30$	184,44	Column flange - tension - group
$F_{t,wc,Rd(2+1)} - \sum 1^1 F_{tj,Rd} = 668,47 - 240,30$	428,16	Column web - tension - group
$F_{t,ep,Rd(2+1)} - \sum 1^1 F_{tj,Rd} = 501,38 - 240,30$	261,07	Front plate - tension - group
$F_{t,wb,Rd(2+1)} - \sum 1^1 F_{tj,Rd} = 1286,57 - 240,30$	1046,27	Beam web - tension - group

RESISTANCE OF THE BOLT ROW NO. 3

F_{t3,Rd,comp} - Formula	F_{t3,Rd,comp}	Component
$F_{t3,Rd} = \text{Min} (F_{t3,Rd,comp})$	94,64	Bolt row resistance
$F_{t,fc,Rd(3)} = 243,72$	243,72	Column flange - tension
$F_{t,wc,Rd(3)} = 566,26$	566,26	Column web - tension
$F_{t,ep,Rd(3)} = 282,24$	282,24	Front plate - tension
$F_{t,wb,Rd(3)} = 908,10$	908,10	Beam web - tension
$B_{p,Rd} = 641,94$	641,94	Bolts due to shear punching
$V_{wp,Rd}/b - \sum 1^2 F_{tj,Rd} = 642,32 - 424,74$	217,57	Web panel - shear
$F_{c,wc,Rd} - \sum 1^2 F_{tj,Rd} = 519,38 - 424,74$	94,64	Column web - compression
$F_{c,fb,Rd} - \sum 1^2 F_{tj,Rd} = 1570,76 - 424,74$	1146,01	Beam flange - compression
$F_{c,wb,Rd} - \sum 1^2 F_{tj,Rd} = 1641,98 - 424,74$	1217,23	Beam web - compression
$F_{t,fc,Rd(3+2)} - \sum 2^2 F_{tj,Rd} = 445,26 - 184,44$	260,82	Column flange - tension - group
$F_{t,wc,Rd(3+2)} - \sum 2^2 F_{tj,Rd} = 737,36 - 184,44$	552,92	Column web - tension - group
$F_{t,fc,Rd(3+2+1)} - \sum 2^1 F_{tj,Rd} = 661,91 - 424,74$	237,17	Column flange - tension - group

F_{t3,Rd,comp} - Formula	F_{t3,Rd,comp}	Component
$F_{t,wc,Rd(3+2+1)} - \sum 2^1 F_{tj,Rd} = 871,06 - 424,74$	446,31	Column web - tension - group
$F_{t,ep,Rd(3+2)} - \sum 2^2 F_{tj,Rd} = 503,89 - 184,44$	319,45	Front plate - tension - group
$F_{t,wb,Rd(3+2)} - \sum 2^2 F_{tj,Rd} = 1303,11 - 184,44$	1118,67	Beam web - tension - group
$F_{t,ep,Rd(3+2+1)} - \sum 2^1 F_{tj,Rd} = 772,95 - 424,74$	348,20	Front plate - tension - group
$F_{t,wb,Rd(3+2+1)} - \sum 2^1 F_{tj,Rd} = 2067,18 - 424,74$	1642,44	Beam web - tension - group

SUMMARY TABLE OF FORCES

Nr	h_j	F_{tj,Rd}	F_{t,fc,Rd}	F_{t,wc,Rd}	F_{t,ep,Rd}	F_{t,wb,Rd}	F_{t,Rd}	B_{p,Rd}
1	492	240,30	240,30	549,80	282,24	1022,18	282,24	641,94
2	342	184,44	255,41	618,64	282,24	908,10	282,24	641,94
3	92	94,64	243,72	566,26	282,24	908,10	282,24	641,94

CONNECTION RESISTANCE FOR BENDING M_{j,Rd}

$$M_{j,Rd} = \sum h_j F_{tj,Rd}$$

$$M_{j,Rd} = 189,89 \text{ [kN*m]} \quad \text{Connection resistance for bending} \quad [6.2]$$

$$M_{b1,Ed} / M_{j,Rd} \leq 1,0 \quad 0,77 < 1,00 \quad \text{verified} \quad (0,77)$$

Connection resistance for shear

$$a_v = 0,60 \quad \text{Coefficient for calculation of } F_{v,Rd} \quad [\text{Table 3.4}]$$

$$b_{l,f} = 0,97 \quad \text{Reduction factor for long connections} \quad [3.8]$$

$$F_{v,Rd} = 117,62 \text{ [kN]} \quad \text{Shear resistance of a single bolt} \quad [\text{Table 3.4}]$$

$$F_{t,Rd,max} = 141,12 \text{ [kN]} \quad \text{Tensile resistance of a single bolt} \quad [\text{Table 3.4}]$$

$$F_{b,Rd,int} = 283,80 \text{ [kN]} \quad \text{Bearing resistance of an intermediate bolt} \quad [\text{Table 3.4}]$$

$$F_{b,Rd,ext} = 283,80 \text{ [kN]} \quad \text{Bearing resistance of an outermost bolt} \quad [\text{Table 3.4}]$$

Nr	F_{tj,Rd,N}	F_{tj,Ed,N}	F_{tj,Rd,M}	F_{tj,Ed,M}	F_{tj,Ed}	F_{vj,Rd}
1	282,24	-3,63	240,30	186,00	182,38	126,67
2	282,24	-3,63	184,44	142,76	139,14	152,41
3	282,24	-3,63	94,64	73,25	69,63	193,79

F_{tj,Rd,N} – Bolt row resistance for simple tension

F_{tj,Ed,N} – Force due to axial force in a bolt row

F_{tj,Rd,M} – Bolt row resistance for simple bending

F_{tj,Ed,M} – Force due to moment in a bolt row

F_{tj,Ed} – Maximum tensile force in a bolt row

$F_{tj,Rd,N}$ – Bolt row resistance for simple tension

$F_{vj,Rd}$ – Reduced bolt row resistance

$$F_{tj,Ed,N} = N_{j,Ed} F_{tj,Rd,N} / N_{j,Rd}$$

$$F_{tj,Ed,M} = M_{j,Ed} F_{tj,Rd,M} / M_{j,Rd}$$

$$F_{tj,Ed} = F_{tj,Ed,N} + F_{tj,Ed,M}$$

$$F_{vj,Rd} = \text{Min} (n_h F_{v,Ed} / (1 - F_{tj,Ed} / (1.4 n_h F_{t,Rd,max})), n_h F_{v,Rd}, n_h F_{b,Rd})$$

$$V_{j,Rd} = n_h \sum 1^n F_{vj,Rd} \quad [\text{Table 3.4}]$$

$$V_{j,Rd} = 472,86 \text{ [kN]} \quad \text{Connection resistance for shear} \quad [\text{Table 3.4}]$$

$$V_{b1,Ed} / V_{j,Rd} \leq 1,0 \quad 0,17 < 1,00 \quad \text{verified} \quad (0,17)$$

Weld resistance

$$A_w = 14190 \text{ [mm}^2 \text{]} \quad \text{Area of all welds} \quad [4.5.3.2(2)]$$

$$A_{wy} = 8403 \text{ [mm}^2 \text{]} \quad \text{Area of horizontal welds} \quad [4.5.3.2(2)]$$

$$A_{wz} = 5787 \text{ [mm}^2 \text{]} \quad \text{Area of vertical welds} \quad [4.5.3.2(2)]$$

$$I_{wy} = \begin{matrix} 53669036 \\ 0 \end{matrix} \text{ [mm}^4 \text{]} \quad \text{Moment of inertia of the weld arrangement with respect to the} \\ \text{hor. axis} \quad [4.5.3.2(5)]$$

$$s^{\wedge \text{max}} = t^{\wedge \text{max}} = 61,34 \text{ [MPa]} \quad \text{Normal stress in a weld} \quad [4.5.3.2(6)]$$

$$s^{\wedge} = t^{\wedge} = 52,05 \text{ [MPa]} \quad \text{Stress in a vertical weld} \quad [4.5.3.2(5)]$$

$$t_{II} = 14,00 \text{ [MPa]} \quad \text{Tangent stress} \quad [4.5.3.2(5)]$$

$$b_w = 0,85 \quad \text{Correlation coefficient} \quad [4.5.3.2(7)]$$

$$\ddot{O}[s^{\wedge \text{max}^2} + 3*(t^{\wedge \text{max}^2})] \leq f_u / (b_w * g_{M2}) \quad 122,68 < 404,71 \quad \text{verified} \quad (0,30)$$

$$\ddot{O}[s^{\wedge^2} + 3*(t^{\wedge^2} + t_{II}^2)] \leq f_u / (b_w * g_{M2}) \quad 106,90 < 404,71 \quad \text{verified} \quad (0,26)$$

$$s^{\wedge} \leq 0.9 * f_u / g_{M2} \quad 61,34 < 309,60 \quad \text{verified} \quad (0,20)$$

Connection stiffness

$$t_{wash} = 4 \text{ [mm]} \quad \text{Washer thickness} \quad [6.2.6.3.(2)]$$

$$h_{head} = 14 \text{ [mm]} \quad \text{Bolt head height} \quad [6.2.6.3.(2)]$$

$$h_{nut} = 20 \text{ [mm]} \quad \text{Bolt nut height} \quad [6.2.6.3.(2)]$$

$$L_b = 62 \text{ [mm]} \quad \text{Bolt length} \quad [6.2.6.3.(2)]$$

$$k_{10} = 6 \text{ [mm]} \quad \text{Stiffness coefficient of bolts} \quad [6.3.2.(1)]$$

STIFFNESSES OF BOLT ROWS

Nr	h _j	k ₃	k ₄	k ₅	k _{eff,j}	k _{eff,j} h _j	k _{eff,j} h _j ²
					Sum	1278	503757
1	492	4	6	8	1	706	347330
2	342	3	5	6	1	416	142085
3	92	5	8	8	2	156	14342

$$k_{eff,j} = 1 / (\sum 3^5 (1 / k_{i,j})) \quad [6.3.3.1.(2)]$$

$$z_{eq} = \sum_j k_{eff,j} h_j^2 / \sum_j k_{eff,j} h_j$$

$$z_{eq} = 394 \quad [\text{mm}] \quad \text{Equivalent force arm} \quad [6.3.3.1.(3)]$$

$$k_{eq} = \sum_j k_{eff,j} h_j / z_{eq}$$

$$k_{eq} = 3 \quad [\text{mm}] \quad \text{Equivalent stiffness coefficient of a bolt arrangement} \quad [6.3.3.1.(1)]$$

$$A_{vc} = 4495 \quad [\text{mm}^2] \quad \text{Shear area} \quad \text{EN1993-1-1:[6.2.6.(3)]}$$

$$b = 1,00 \quad \text{Transformation parameter} \quad [5.3.(7)]$$

$$z = 394 \quad [\text{mm}] \quad \text{Lever arm} \quad [6.2.5]$$

$$k_1 = 4 \quad [\text{mm}] \quad \text{Stiffness coefficient of the column web panel subjected to shear} \quad [6.3.2.(1)]$$

$$b_{eff,c,wc} = 272 \quad [\text{mm}] \quad \text{Effective width of the web for compression} \quad [6.2.6.2.(1)]$$

$$t_{wc} = 10 \quad [\text{mm}] \quad \text{Effective thickness of the column web} \quad [6.2.6.2.(6)]$$

$$d_c = 297 \quad [\text{mm}] \quad \text{Height of compressed web} \quad [6.2.6.2.(1)]$$

$$k_2 = 6 \quad [\text{mm}] \quad \text{Stiffness coefficient of the compressed column web} \quad [6.3.2.(1)]$$

$$S_{j,ini} = E z_{eq}^2 / \sum_i (1 / k_1 + 1 / k_2 + 1 / k_{eq}) \quad [6.3.1.(4)]$$

$$S_{j,ini} = 46386,09 \quad [\text{kN*m}] \quad \text{Initial rotational stiffness} \quad [6.3.1.(4)]$$

$$m = 1,50 \quad \text{Stiffness coefficient of a connection} \quad [6.3.1.(6)]$$

$$S_j = S_{j,ini} / m \quad [6.3.1.(4)]$$

$$S_j = 30995,75 \quad [\text{kN*m}] \quad \text{Final rotational stiffness} \quad [6.3.1.(4)]$$

Connection classification due to stiffness.

$$S_{j,rig} = 54829,54 \quad [\text{kN*m}] \quad \text{Stiffness of a rigid connection} \quad [5.2.2.5]$$

$$S_{j,pin} = 3426,85 \quad [\text{kN*m}] \quad \text{Stiffness of a pinned connection} \quad [5.2.2.5]$$

$$S_{j,pin} \leq S_{j,ini} < S_{j,rig} \quad \text{SEMI-RIGID}$$

Weakest component:

COLUMN WEB - COMPRESSION

Remarks

Bolts vertical spacing is too large.	250 [mm] > 200 [mm]
The thickness of bracket web is less than the thickness of beam web	8 [mm] < 10 [mm]
The thickness of bracket flange is less than the thickness of beam flange	12 [mm] < 16 [mm]

Connection conforms to the code**Ratio 0,77**

Mjerodavne vrijednosti dobivene su na temelju statičkog proračuna glavnog okvira u programskom paketu Robot Structural Analysis.

$$M_{y,Ed} = 146,98 \text{ kNm}$$

$$V_{Ed} = 81,01 \text{ kN}$$

Proračun vijaka**Vijci: M20 - k.v. 8.8.**

Granica popuštanja: $f_{yb} = 640 \text{ N/mm}^2$

Vlačna čvrstoća: $f_{ub} = 800 \text{ N/mm}^2$

Promjer jezgre vijka: $d = 20 \text{ mm}$

Promjer rupe za vijak: $d_0 = 22 \text{ mm}$

Vlačna površina pop. presjeka vijka: $A_s = 245 \text{ mm}^2$

Čelična ploča: S275 t = 20 mm

Vlačna čvrstoća: $f_u = 430 \text{ N/mm}^2$

Otpornost vijaka na vlak

Otpornost jednog vijka opterećenog na vlak:

$$F_{t,Rd} = \frac{k_2 \cdot f_{ub} \cdot A_s}{\gamma_{M2}} = \frac{0,9 \cdot 800 \cdot 245}{1,25} = 141,12 \text{ kN}$$

$k_2 = 0,9$ za ostale vijke

Pretpostavlja se da prvi red vijaka preuzima maksimalno opterećenje koje može preuzeti, dok ostali redovi vijaka preuzimaju opterećenje prema raspodjeli.

Vrijednosti **h_j [mm]** označavaju udaljenost određenog reda vijaka od tlačnog ruba. Vrijednosti preraspodjele preuzete su iz programa Robot Structural Analysis.

Red vijaka	h _j	F _{tj,Rd}
1	492	240,30
2	342	184,44
3	92	94,64

$$M_{t,Rd} = \sum h_j \cdot F_{tj,Rd} = 189,89 \text{ kN}$$

Uvjet nosivosti:

$$M_{y,Ed} \leq M_{t,Rd}$$

$$146,98 \text{ kNm} < 189,89 \text{ kNm} \quad (82\%)$$

Otpornost vijaka na posmik

Otpornost jednog vijaka opterećenog na posmik:

$$F_{v,Rd} = \frac{\alpha_v \cdot f_{ub} \cdot A_s}{\gamma_{M2}}$$

$$\alpha_v = 0,6$$

$$F_{v,Rd} = \frac{0,6 \cdot 800 \cdot 245}{1,25} = 94,08 \text{ kN}$$

$$F_{v,Rd} = 94,08 \cdot 6 = 594,48 \text{ kN}$$

Uvjet nosivosti:

$$F_{v,Ed} \leq F_{v,Rd}$$

$$81,01 \text{ kN} < 594,48 \text{ kN} \quad (14\%)$$

Otpornost na pritisak po omotaču rupe osnovnog materijala

$$e_1 = \begin{pmatrix} 100 \\ 360 \end{pmatrix} \text{ mm} \quad \begin{array}{l} \text{od gornjeg ruba} \\ \text{od donjeg ruba} \end{array}$$

$$e_2 = \begin{pmatrix} 75 \\ 75 \end{pmatrix} \text{ mm} \quad \begin{array}{l} \text{od desnog ruba} \\ \text{od lijevog ruba} \end{array}$$

$$p_1 = 150 \text{ mm}$$

$$p_2 = 250 \text{ mm}$$

Promjer vijka: $d = 20 \text{ mm}$

Promjer rupe za vijak: $d_0 = 22 \text{ mm}$

Debljina čelične ploče: $t = 20 \text{ mm}$

Otpornost na pritisak po omotaču rupe jednog vijka:

$$\text{- za krajnje vijke: } \alpha_d = \frac{e_1}{3 \cdot d_0} = \frac{75}{3 \cdot 22} = 1,14$$

$$\text{- za unutarnje vijke: } \alpha_d = \frac{p_1}{3 \cdot d_0} - \frac{1}{4} = \frac{150}{3 \cdot 22} - \frac{1}{4} = 2,02$$

$$\alpha_b = \min\left(\alpha_d; \frac{f_{ub}}{f_u}; 1\right) = \min\left(1,14; \frac{800}{430}; 1\right) = 1$$

$$\text{- za krajnje vijke: } k_1 = \min\left(2,8 \cdot \frac{e_2}{d_0} - 1,7; 2,5\right) = \min\left(2,8 \cdot \frac{75}{22} - 1,7; 2,5\right) = 2,5$$

$$\text{- za unutarnje vijke: } k_1 = \min\left(1,4 \cdot \frac{p_2}{d_0} - 1,7; 2,5\right) = \min\left(1,4 \cdot \frac{250}{22} - 1,7; 2,5\right) = 2,5$$

$$F_{b,Rd} = \frac{k_1 \cdot \alpha_b \cdot f_u \cdot d \cdot t}{\gamma_{M2}} = \frac{2,5 \cdot 1 \cdot 430 \cdot 20 \cdot 20}{1,25} = 344 \text{ kN}$$

Uvjet nosivosti:

$$F_{v,Ed} \leq \overline{F_{b,Rd}}$$

$$81,01 \text{ kN} < 344 \text{ kN} \quad (24\%)$$

Interakcija posmika i vlaka

Uvjet nosivosti:

$$\frac{F_{v,Ed}}{F_{v,Rd}} + \frac{M_{y,Ed}}{1,40 \cdot M_{t,Rd}} \leq 1$$

$$\frac{81,01/6}{594,48} + \frac{146,98}{265,85} = 0,58 < 1$$

Proračun zavora

$$F_{t,Ed} = \frac{146,98}{0,85} = 172,92 \text{ kN}$$

$$\text{Djelovanje na zavar: } F_{w,Ed} = \sqrt{(0,5 * V_{z,Ed})^2 + F_{t,Ed}^2} = \sqrt{40,51^2 + 172,92^2} = 177,60 \text{ kN}$$

Duljina zavara:

$$L = 2 \cdot (2b - t_w - 2r) = 2 \cdot (2 \cdot 300 - 16,5 - 2 \cdot 27) = 1073 \text{ mm}$$

Proračunska otpornost zavara :

- Uzeta je debljina zavara od 10 mm.

$$F_{w,Rd} = \frac{\frac{f_u}{\sqrt{3} \cdot \beta_w} \cdot a \cdot L}{\gamma_{M2}} = \frac{\frac{43,0}{\sqrt{3} \cdot 0,80} \cdot 1,0 \cdot 107,3}{1,25} = 2663,84 \text{ kN}$$

Uvjet nosivosti:

$$\frac{F_{w,Ed}}{F_{w,Rd}} = \frac{177,60}{2663,84} = 0,1 \leq 1$$

8.2. Priključak grednih nosača



Autodesk Robot Structural Analysis Professional 2022

Design of fixed beam-to-beam connection

EN 1993-1-8:2005/AC:2009



Ratio
0,95

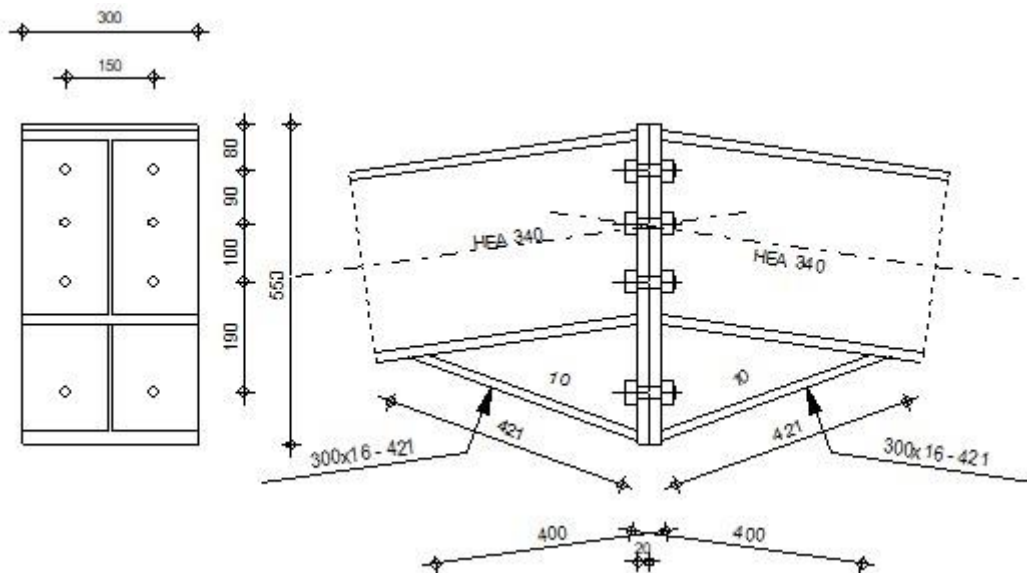

General

Connection no.: 2

Connection name: Priključak nosača u sljemenu

Structure node: 32

Structure members: 27, 28

Geometry

Left side

Beam

Section: HEA 340

Member no.: 27

$a = -171,9$ [Deg] Inclination angle

$h_{bl} = 330$ [mm] Height of beam section

$b_{fbl} = 300$ [mm] Width of beam section

$t_{wbl} = 10$ [mm] Thickness of the web of beam section

$a =$	-171,9	[Deg]	Inclination angle
$t_{fbl} =$	16	[mm]	Thickness of the flange of beam section
$r_{bl} =$	27	[mm]	Radius of beam section fillet
$A_{bl} =$	13347	[mm ²]	Cross-sectional area of a beam
$I_{xbl} =$	276931000	[mm ⁴]	Moment of inertia of the beam section

Material: S 275

$f_{yb} =$	275,00	[MPa]	Resistance
------------	--------	-------	------------

Right side

Beam

Section: HEA 340

Member no.: 28

$a =$	-8,1	[Deg]	Inclination angle
$h_{br} =$	330	[mm]	Height of beam section
$b_{fbr} =$	300	[mm]	Width of beam section
$t_{wbr} =$	10	[mm]	Thickness of the web of beam section
$t_{fbr} =$	16	[mm]	Thickness of the flange of beam section
$r_{br} =$	27	[mm]	Radius of beam section fillet
$A_{br} =$	13347	[mm ²]	Cross-sectional area of a beam
$I_{xbr} =$	276931000	[mm ⁴]	Moment of inertia of the beam section

Material: S 275

$f_{yb} =$	275,00	[MPa]	Resistance
------------	--------	-------	------------

Bolts

The shear plane passes through the UNTHREADED portion of the bolt.

$d =$	20	[mm]	Bolt diameter
Class =	8.8		Bolt class
$F_{tRd} =$	141,12	[kN]	Tensile resistance of a bolt
$n_h =$	2		Number of bolt columns
$n_v =$	4		Number of bolt rows
$h_1 =$	80	[mm]	Distance between first bolt and upper edge of front plate

$d = 20$ [mm] Bolt diameter

Horizontal spacing $e_i = 150$ [mm]

Vertical spacing $p_i = 90;100;190$ [mm]

Plate

$h_{pr} = 550$ [mm] Plate height

$b_{pr} = 300$ [mm] Plate width

$t_{pr} = 20$ [mm] Plate thickness

Material: S 355

$f_{ypr} = 355,00$ [MPa] Resistance

Lower stiffener

$w_{rd} = 300$ [mm] Plate width

$t_{frd} = 16$ [mm] Flange thickness

$h_{rd} = 200$ [mm] Plate height

$t_{wrd} = 10$ [mm] Web thickness

$l_{rd} = 400$ [mm] Plate length

$\alpha_d = 19,9$ [Deg] Inclination angle

Material: S 355

$f_{ybu} = 355,00$ [MPa] Resistance

Fillet welds

$a_w = 6$ [mm] Web weld

$a_f = 7$ [mm] Flange weld

$a_{fd} = 5$ [mm] Horizontal weld

Material factors

$g_{M0} = 1,00$ Partial safety factor [2.2]

$g_{M1} = 1,00$ Partial safety factor [2.2]

$g_{M2} = 1,25$ Partial safety factor [2.2]

$g_{M3} = 1,25$ Partial safety factor [2.2]

Loads

Ultimate limit state

Case: 148: COMB128 (1+2)*1.35+(4+18)*1.50+7*0.90

$M_{b1,Ed} = -172,30$ [kN*m] Bending moment in the right beam

$V_{b1,Ed} = -10,83$ [kN] Shear force in the right beam

$N_{b1,Ed} = 1,56$ [kN] Axial force in the right beam

Results

Beam resistances

TENSION

$A_b = 13347$ [mm²] Area EN1993-1-1:[6.2.3]

$N_{tb,Rd} = A_b f_{yb} / g_{M0}$

$N_{tb,Rd} = 3670,51$ [kN] Design tensile resistance of the section EN1993-1-1:[6.2.3]

SHEAR

$A_{vb} = 6495$ [mm²] Shear area EN1993-1-1:[6.2.6.(3)]

$V_{cb,Rd} = A_{vb} (f_{yb} / \sqrt{3}) / g_{M0}$

$V_{cb,Rd} = 1031,23$ [kN] Design sectional resistance for shear EN1993-1-1:[6.2.6.(2)]

$V_{b1,Ed} / V_{cb,Rd} \leq 1,0$	$0,01 < 1,00$	verified	(0,01)
----------------------------------	---------------	----------	--------

BENDING - PLASTIC MOMENT (WITHOUT BRACKETS)

$W_{plb} = 1850620$ [mm³] Plastic section modulus EN1993-1-1:[6.2.5.(2)]

$M_{b,pl,Rd} = W_{plb} f_{yb} / g_{M0}$

$M_{b,pl,Rd} = 508,9$ [kN*m] Plastic resistance of the section for bending (without stiffeners) EN1993-1-1:[6.2.5.(2)]

BENDING ON THE CONTACT SURFACE WITH PLATE OR CONNECTED ELEMENT

$W_{pl} = 3202426$ [mm³] Plastic section modulus EN1993-1-1:[6.2.5]

$M_{cb,Rd} = W_{pl} f_{yb} / g_{M0}$

$M_{cb,Rd} = 880,67$ [kN*m] Design resistance of the section for bending EN1993-1-1:[6.2.5]

FLANGE AND WEB - COMPRESSION

$M_{cb,Rd} = 880,67$ [kN*m] Design resistance of the section for bending EN1993-1-1:[6.2.5]

$h_f = 517$ [mm] Distance between the centroids of flanges [6.2.6.7.(1)]

$F_{c,fb,Rd} = M_{cb,Rd} / h_f$

$F_{c,fb,Rd} = 1705,06$ [kN] Resistance of the compressed flange and web [6.2.6.7.(1)]

Geometrical parameters of a connection

EFFECTIVE LENGTHS AND PARAMETERS - FRONT PLATE

Nr	m	m _x	e	e _x	p	l _{eff,cp}	l _{eff,nc}	l _{eff,1}	l _{eff,2}	l _{eff,cp,g}	l _{eff,nc,g}	l _{eff,1,g}	l _{eff,2,g}
1	63	-	75	-	190	399	393	393	393	389	315	315	315
2	63	-	75	-	145	399	348	348	348	290	145	145	145
3	63	-	75	-	95	399	348	348	348	190	95	95	95
4	63	-	75	-	90	399	348	348	348	289	219	219	219

m – Bolt distance from the web

m_x – Bolt distance from the beam flange

e – Bolt distance from the outer edge

e_x – Bolt distance from the horizontal outer edge

p – Distance between bolts

l_{eff,cp} – Effective length for a single bolt row in the circular failure mode

l_{eff,nc} – Effective length for a single bolt row in the non-circular failure mode

l_{eff,1} – Effective length for a single bolt row for mode 1

l_{eff,2} – Effective length for a single bolt row for mode 2

l_{eff,cp,g} – Effective length for a group of bolts in the circular failure mode

l_{eff,nc,g} – Effective length for a group of bolts in the non-circular failure mode

l_{eff,1,g} – Effective length for a group of bolts for mode 1

l_{eff,2,g} – Effective length for a group of bolts for mode 2

Connection resistance for tension

F_{t,Rd} = 141,12 [kN] Bolt resistance for tension [Table 3.4]

B_{p,Rd} = 425,25 [kN] Punching shear resistance of a bolt [Table 3.4]

N_{j,Rd} = Min (N_{tb,Rd}, n_v n_h F_{t,Rd}, n_v n_h B_{p,Rd})

N_{j,Rd} = 1128,96 [kN] Connection resistance for tension [6.2]

N_{b1,Ed} / N_{j,Rd} ≤ 1,0 0,00 < 1,00 **verified** (0,00)

Connection resistance for bending

$F_{t,Rd} = 141,12$ [kN] Bolt resistance for tension [Table 3.4]

$B_{p,Rd} = 425,25$ [kN] Punching shear resistance of a bolt [Table 3.4]

$F_{t,fc,Rd}$ – column flange resistance due to bending

$F_{t,wc,Rd}$ – column web resistance due to tension

$F_{t,ep,Rd}$ – resistance of the front plate due to bending

$F_{t,wb,Rd}$ – resistance of the web in tension

$F_{t,fc,Rd} = \text{Min} (F_{T,1,fc,Rd}, F_{T,2,fc,Rd}, F_{T,3,fc,Rd})$ [6.2.6.4], [Tab.6.2]

$F_{t,wc,Rd} = w b_{\text{eff},t,wc} t_{wc} f_{yc} / g_{M0}$ [6.2.6.3.(1)]

$F_{t,ep,Rd} = \text{Min} (F_{T,1,ep,Rd}, F_{T,2,ep,Rd}, F_{T,3,ep,Rd})$ [6.2.6.5], [Tab.6.2]

$F_{t,wb,Rd} = b_{\text{eff},t,wb} t_{wb} f_{yb} / g_{M0}$ [6.2.6.8.(1)]

RESISTANCE OF THE BOLT ROW NO. 1

$F_{t1,Rd,comp}$ - Formula	$F_{t1,Rd,comp}$	Component
$F_{t1,Rd} = \text{Min} (F_{t1,Rd,comp})$	282,24	Bolt row resistance
$F_{t,ep,Rd(1)} = 282,24$	282,24	Front plate - tension
$F_{t,wb,Rd(1)} = 1027,61$	1027,61	Beam web - tension
$B_{p,Rd} = 850,49$	850,49	Bolts due to shear punching
$F_{c,fb,Rd} = 1705,06$	1705,06	Beam flange - compression

RESISTANCE OF THE BOLT ROW NO. 2

$F_{t2,Rd,comp}$ - Formula	$F_{t2,Rd,comp}$	Component
$F_{t2,Rd} = \text{Min} (F_{t2,Rd,comp})$	259,16	Bolt row resistance
$F_{t,ep,Rd(2)} = 282,24$	282,24	Front plate - tension
$F_{t,wb,Rd(2)} = 908,10$	908,10	Beam web - tension
$B_{p,Rd} = 850,49$	850,49	Bolts due to shear punching
$F_{c,fb,Rd} - \sum_1^1 F_{tj,Rd} = 1705,06 - 282,24$	1422,82	Beam flange - compression
$F_{t,ep,Rd(2+1)} - \sum_1^1 F_{tj,Rd} = 541,40 - 282,24$	259,16	Front plate - tension - group
$F_{t,wb,Rd(2+1)} - \sum_1^1 F_{tj,Rd} = 1200,56 - 282,24$	918,32	Beam web - tension - group

Additional reduction of the bolt row resistance

$F_{t2,Rd} = F_{t1,Rd} h_2/h_1$

$$F_{t2,Rd} = 160,82 \text{ [kN]} \quad \text{Reduced bolt row resistance} \quad [6.2.7.2.(9)]$$

RESISTANCE OF THE BOLT ROW NO. 3

$F_{t3,Rd,comp}$ - Formula	$F_{t3,Rd,comp}$	Component
$F_{t3,Rd} = \text{Min} (F_{t3,Rd,comp})$	268,00	Bolt row resistance
$F_{t,ep,Rd(3)} = 282,24$	282,24	Front plate - tension
$F_{t,wb,Rd(3)} = 908,10$	908,10	Beam web - tension
$B_{p,Rd} = 850,49$	850,49	Bolts due to shear punching
$F_{c,fb,Rd} - \sum_1^2 F_{tj,Rd} = 1705,06 - 443,06$	1262,00	Beam flange - compression
$F_{t,ep,Rd(3+2)} - \sum_2^2 F_{tj,Rd} = 428,83 - 160,82$	268,00	Front plate - tension - group
$F_{t,wb,Rd(3+2)} - \sum_2^2 F_{tj,Rd} = 627,00 - 160,82$	466,18	Beam web - tension - group
$F_{t,ep,Rd(3+2+1)} - \sum_2^1 F_{tj,Rd} = 743,00 - 443,06$	299,93	Front plate - tension - group
$F_{t,wb,Rd(3+2+1)} - \sum_2^1 F_{tj,Rd} = 1448,75 - 443,06$	1005,68	Beam web - tension - group

Additional reduction of the bolt row resistance

$$F_{t3,Rd} = F_{t1,Rd} h_3/h_1$$

$$F_{t3,Rd} = 96,92 \text{ [kN]} \quad \text{Reduced bolt row resistance} \quad [6.2.7.2.(9)]$$

RESISTANCE OF THE BOLT ROW NO. 4

$F_{t4,Rd,comp}$ - Formula	$F_{t4,Rd,comp}$	Component
$F_{t4,Rd} = \text{Min} (F_{t4,Rd,comp})$	282,24	Bolt row resistance
$F_{t,ep,Rd(4)} = 282,24$	282,24	Front plate - tension
$F_{t,wb,Rd(4)} = 908,10$	908,10	Beam web - tension
$B_{p,Rd} = 850,49$	850,49	Bolts due to shear punching
$F_{c,fb,Rd} - \sum_1^3 F_{tj,Rd} = 1705,06 - 539,98$	1165,08	Beam flange - compression
$F_{t,ep,Rd(4+3)} - \sum_3^3 F_{tj,Rd} = 466,67 - 96,92$	369,75	Front plate - tension - group
$F_{t,wb,Rd(4+3)} - \sum_3^3 F_{tj,Rd} = 819,80 - 96,92$	722,88	Beam web - tension - group
$F_{t,ep,Rd(4+3+2)} - \sum_3^2 F_{tj,Rd} = 693,90 - 257,74$	436,16	Front plate - tension - group
$F_{t,wb,Rd(4+3+2)} - \sum_3^2 F_{tj,Rd} = 1198,61 - 257,74$	940,87	Beam web - tension - group
$F_{t,ep,Rd(4+3+2+1)} - \sum_3^1 F_{tj,Rd} = 1008,07 - 539,98$	468,09	Front plate - tension - group
$F_{t,wb,Rd(4+3+2+1)} - \sum_3^1 F_{tj,Rd} = 2020,36 - 539,98$	1480,37	Beam web - tension - group

Additional reduction of the bolt row resistance

$$F_{t4,Rd} = F_{t1,Rd} h_4/h_1$$

$$F_{t4,Rd} = 39,41 \text{ [kN]} \quad \text{Reduced bolt row resistance} \quad [6.2.7.2.(9)]$$

SUMMARY TABLE OF FORCES

Nr	h_j	$F_{tj,Rd}$	$F_{t,fc,Rd}$	$F_{t,wc,Rd}$	$F_{t,ep,Rd}$	$F_{t,wb,Rd}$	$F_{t,Rd}$	$B_{p,Rd}$
1	442	282,24	-	-	282,24	1027,61	282,24	850,49
2	252	160,82	-	-	282,24	908,10	282,24	850,49
3	152	96,92	-	-	282,24	908,10	282,24	850,49
4	62	39,41	-	-	282,24	908,10	282,24	850,49

CONNECTION RESISTANCE FOR BENDING $M_{j,Rd}$

$$M_{j,Rd} = \sum h_j F_{tj,Rd}$$

$$M_{j,Rd} = 182,26 \text{ [kN*m]} \quad \text{Connection resistance for bending} \quad [6.2]$$

$$M_{b1,Ed} / M_{j,Rd} \leq 1,0 \quad 0,95 < 1,00 \quad \text{verified} \quad (0,95)$$

Connection resistance for shear

$$a_v = 0,60 \quad \text{Coefficient for calculation of } F_{v,Rd} \quad [\text{Table 3.4}]$$

$$b_{Lf} = 0,98 \quad \text{Reduction factor for long connections} \quad [3.8]$$

$$F_{v,Rd} = 118,22 \text{ [kN]} \quad \text{Shear resistance of a single bolt} \quad [\text{Table 3.4}]$$

$$F_{t,Rd,max} = 141,12 \text{ [kN]} \quad \text{Tensile resistance of a single bolt} \quad [\text{Table 3.4}]$$

$$F_{b,Rd,int} = 376,00 \text{ [kN]} \quad \text{Bearing resistance of an intermediate bolt} \quad [\text{Table 3.4}]$$

$$F_{b,Rd,ext} = 376,00 \text{ [kN]} \quad \text{Bearing resistance of an outermost bolt} \quad [\text{Table 3.4}]$$

Nr	$F_{tj,Rd,N}$	$F_{tj,Ed,N}$	$F_{tj,Rd,M}$	$F_{tj,Ed,M}$	$F_{tj,Ed}$	$F_{vj,Rd}$
1	282,24	0,39	282,24	266,82	267,21	76,55
2	282,24	0,39	160,82	152,04	152,43	145,24
3	282,24	0,39	96,92	91,62	92,01	181,39
4	282,24	0,39	39,41	37,25	37,64	213,92

$F_{tj,Rd,N}$ – Bolt row resistance for simple tension

$F_{tj,Ed,N}$ – Force due to axial force in a bolt row

$F_{tj,Rd,M}$ – Bolt row resistance for simple bending

$F_{tj,Rd,N}$ – Bolt row resistance for simple tension

$F_{tj,Ed,M}$ – Force due to moment in a bolt row

$F_{tj,Ed}$ – Maximum tensile force in a bolt row

$F_{vj,Rd}$ – Reduced bolt row resistance

$$F_{tj,Ed,N} = N_{j,Ed} F_{tj,Rd,N} / N_{j,Rd}$$

$$F_{tj,Ed,M} = M_{j,Ed} F_{tj,Rd,M} / M_{j,Rd}$$

$$F_{tj,Ed} = F_{tj,Ed,N} + F_{tj,Ed,M}$$

$$F_{vj,Rd} = \text{Min} (n_h F_{v,Ed} / (1 - F_{tj,Ed} / (1.4 n_h F_{t,Rd,max})), n_h F_{v,Rd}, n_h F_{b,Rd})$$

$$V_{j,Rd} = n_h \sum_1^n F_{vj,Rd} \quad [\text{Table 3.4}]$$

$$V_{j,Rd} = 617,10 \text{ [kN]} \quad \text{Connection resistance for shear} \quad [\text{Table 3.4}]$$

$$V_{b1,Ed} / V_{j,Rd} \leq 1,0 \quad 0,02 < 1,00 \quad \text{verified} \quad (0,02)$$

Weld resistance

$$A_w = 14444 \text{ [mm}^2\text{]} \quad \text{Area of all welds} \quad [4.5.3.2(2)]$$

$$A_{wy} = 9303 \text{ [mm}^2\text{]} \quad \text{Area of horizontal welds} \quad [4.5.3.2(2)]$$

$$A_{wz} = 5141 \text{ [mm}^2\text{]} \quad \text{Area of vertical welds} \quad [4.5.3.2(2)]$$

$$I_{wy} = 4866283 \text{ [mm}^4\text{]} \quad \text{Moment of inertia of the weld arrangement with respect to the hor. axis} \quad [4.5.3.2(5)]$$

$$s^{\wedge} = t^{\wedge} = 66,62 \text{ [MPa]} \quad \text{Normal stress in a weld} \quad [4.5.3.2(6)]$$

$$s^{\wedge} = t^{\wedge} = 66,62 \text{ [MPa]} \quad \text{Stress in a vertical weld} \quad [4.5.3.2(5)]$$

$$t_{II} = -2,11 \text{ [MPa]} \quad \text{Tangent stress} \quad [4.5.3.2(5)]$$

$$b_w = 0,85 \quad \text{Correlation coefficient} \quad [4.5.3.2(7)]$$

$$\ddot{O}[s^{\wedge}_{max}{}^2 + 3*(t^{\wedge}_{max}{}^2)] \leq f_u / (b_w * g_{M2}) \quad 133,24 < 404,71 \quad \text{verified} \quad (0,33)$$

$$\ddot{O}[s^{\wedge}{}^2 + 3*(t^{\wedge}{}^2 + t_{II}{}^2)] \leq f_u / (b_w * g_{M2}) \quad 133,29 < 404,71 \quad \text{verified} \quad (0,33)$$

$$s^{\wedge} \leq 0.9 * f_u / g_{M2} \quad 66,62 < 309,60 \quad \text{verified} \quad (0,22)$$

Connection stiffness

$t_{wash} = 4$	[mm]	Washer thickness	[6.2.6.3.(2)]
$h_{head} = 14$	[mm]	Bolt head height	[6.2.6.3.(2)]
$h_{nut} = 20$	[mm]	Bolt nut height	[6.2.6.3.(2)]
$L_b = 62$	[mm]	Bolt length	[6.2.6.3.(2)]
$k_{10} = 6$	[mm]	Stiffness coefficient of bolts	[6.3.2.(1)]

STIFFNESSES OF BOLT ROWS

Nr	h_j	k_3	k_4	k_5	$k_{eff,j}$	$k_{eff,j} h_j$	$k_{eff,j} h_j^2$
					Sum	1839	641158
1	442			9	3	1154	509853
2	252			4	2	389	97965
3	152			3	1	168	25439
4	62			6	2	128	7900

$$k_{eff,j} = 1 / (\sum_3^5 (1 / k_{i,j})) \quad [6.3.3.1.(2)]$$

$$z_{eq} = \sum_j k_{eff,j} h_j^2 / \sum_j k_{eff,j} h_j$$

$$z_{eq} = 349 \quad [mm] \quad \text{Equivalent force arm} \quad [6.3.3.1.(3)]$$

$$k_{eq} = \sum_j k_{eff,j} h_j / z_{eq}$$

$$k_{eq} = 5 \quad [mm] \quad \text{Equivalent stiffness coefficient of a bolt arrangement} \quad [6.3.3.1.(1)]$$

$$S_{j,ini} = E z_{eq}^2 k_{eq} \quad [6.3.1.(4)]$$

$$S_{j,ini} = 134643,09 \quad [kN*m] \quad \text{Initial rotational stiffness} \quad [6.3.1.(4)]$$

$$m = 2,57 \quad \text{Stiffness coefficient of a connection} \quad [6.3.1.(6)]$$

$$S_j = S_{j,ini} / m \quad [6.3.1.(4)]$$

$$S_j = 52436,35 \quad [kN*m] \quad \text{Final rotational stiffness} \quad [6.3.1.(4)]$$

Connection classification due to stiffness.

$$S_{j,rig} = 54829,54 \quad [kN*m] \quad \text{Stiffness of a rigid connection} \quad [5.2.2.5]$$

$$S_{j,pin} = 3426,85 \quad [kN*m] \quad \text{Stiffness of a pinned connection} \quad [5.2.2.5]$$

$S_{j,ini} \geq S_{j,rig}$ RIGID

Weakest component:

FRONT PLATE - TENSION

Remarks

The thickness of bracket flange is less than the thickness of beam flange 16 [mm] < 16 [mm]

Connection conforms to the code

Ratio 0,95

Mjerodavne vrijednosti dobivene su na temelju statičkog proračuna glavnog okvira u programskom paketu Robot Structural Analysis.

$$M_{y,Ed} = 172,30 \text{ kNm}$$

$$V_{Ed} = 10,83 \text{ kN}$$

Proračun vijaka

Vijci: M20 - k.v. 8.8.

$$\text{Granica popuštanja: } f_{yb} = 640 \text{ N/mm}^2$$

$$\text{Vlačna čvrstoća: } f_{ub} = 800 \text{ N/mm}^2$$

$$\text{Promjer jezgre vijka: } d = 20 \text{ mm}$$

$$\text{Promjer rupe za vijak: } d_0 = 22 \text{ mm}$$

$$\text{Vlačna površina pop. presjeka vijka: } A_s = 245 \text{ mm}^2$$

Čelična ploča: S275 t = 20 mm

$$\text{Vlačna čvrstoća: } f_u = 430 \text{ N/mm}^2$$

Otpornost vijaka na vlak

Otpornost jednog vijka opterećenog na vlak:

$$F_{t,Rd} = \frac{k_2 \cdot f_{ub} \cdot A_s}{\gamma_{M2}} = \frac{0,9 \cdot 800 \cdot 245}{1,25} = 141,12 \text{ kN}$$

$$k_2 = 0,9 \quad \text{za ostale vijke}$$

Pretpostavlja se da prvi red vijaka preuzima maksimalno opterećenje koje može preuzeti, dok ostali redovi vijaka preuzimaju opterećenje prema raspodjeli.

Vrijednosti **h_j [mm]** označavaju udaljenost određenog reda vijaka od tlačnog ruba. Vrijednosti preraspodjele preuzete su iz programa Robot Structural Analysis.

Red vijaka	h _j	F _{tj,Rd}
1	442	282,24
2	252	160,82
3	152	96,92
4	62	39,41

$$M_{t,Rd} = \sum h_j \cdot F_{tj,Rd} = 182,26 \text{ kN}$$

2Uvjet nosivosti:

$$M_{y,Ed} \leq M_{t,Rd}$$

$$172,30 \text{ kNm} < 182,26 \text{ kNm} \quad (95\%)$$

Otpornost vijaka na posmik

Otpornost jednog vijaka opterećenog na posmik:

$$F_{v,Rd} = \frac{\alpha_v \cdot f_{ub} \cdot A_s}{\gamma_{M2}}$$

$$\alpha_v = 0,6$$

$$F_{v,Rd} = \frac{0,6 \cdot 800 \cdot 245}{1,25} = 94,08 \text{ kN}$$

$$F_{v,Rd} = 94,08 \cdot 8 = 752,64 \text{ kN}$$

Uvjet nosivosti:

$$F_{v,Ed} \leq F_{v,Rd}$$

$$10,83 \text{ kN} < 752,64 \text{ kN} \quad (1\%)$$

Otpornost na pritisak po omotaču rupe osnovnog materijala

$$e_1 = \begin{pmatrix} 80 \\ 180 \end{pmatrix} \text{ mm} \quad \begin{array}{l} \text{od gornjeg ruba} \\ \text{od donjeg ruba} \end{array}$$

$$e_2 = \begin{pmatrix} 75 \\ 75 \end{pmatrix} \text{ mm} \quad \begin{array}{l} \text{od desnog ruba} \\ \text{od lijevog ruba} \end{array}$$

$$p_1 = 90 \text{ mm}$$

$$p_2 = 100 \text{ mm}$$

Promjer vijka: $d = 20 \text{ mm}$

Promjer rupe za vijak: $d_0 = 22 \text{ mm}$

Debljina čelične ploče: $t = 20 \text{ mm}$

Otpornost na pritisak po omotaču rupe jednog vijka:

$$\text{- za krajnje vijke: } \alpha_d = \frac{e_1}{3 \cdot d_0} = \frac{80}{3 \cdot 22} = 1,21$$

$$\text{- za unutarnje vijke: } \alpha_d = \frac{p_1}{3 \cdot d_0} - \frac{1}{4} = \frac{90}{3 \cdot 22} - \frac{1}{4} = 1,11$$

$$\alpha_b = \min\left(\alpha_d; \frac{f_{ub}}{f_u}; 1\right) = \min\left(1,11; \frac{800}{430}; 1\right) = 1$$

$$\text{- za krajnje vijke: } k_1 = \min\left(2,8 \cdot \frac{e_2}{d_0} - 1,7; 2,5\right) = \min\left(2,8 \cdot \frac{75}{22} - 1,7; 2,5\right) = 2,5$$

$$\text{- za unutarnje vijke: } k_1 = \min\left(1,4 \cdot \frac{p_2}{d_0} - 1,7; 2,5\right) = \min\left(1,4 \cdot \frac{75}{22} - 1,7; 2,5\right) = 2,5$$

$$F_{b,Rd} = \frac{k_1 \cdot \alpha_b \cdot f_u \cdot d \cdot t}{\gamma_{M2}} = \frac{2,5 \cdot 1 \cdot 430 \cdot 20 \cdot 20}{1,25} = 344 \text{ kN}$$

Uvjet nosivosti:

$$F_{v,Ed} \leq \overline{F_{b,Rd}}$$

$$10,83 \text{ kN} < 344 \text{ kN} \quad (3\%)$$

Interakcija posmika i vlaka

Uvjet nosivosti:

$$\frac{F_{v,Ed}}{F_{v,Rd}} + \frac{M_{y,Ed}}{1,40 \cdot M_{t,Rd}} \leq 1$$

$$\frac{10,83/10}{94,08} + \frac{172,30}{255,16} = 0,69 < 1$$

Proračun zavora

$$F_{t,Ed} = \frac{172,30}{0,85} = 202,71 \text{ kN}$$

$$\text{Djelovanje na zavar: } F_{w,Ed} = \sqrt{(0,5 * V_{z,Ed})^2 + F_{t,Ed}^2} = \sqrt{5,42^2 + 202,71^2} = 202,78 \text{ kN}$$

Duljina zavara:

$$L = 2 \cdot (2b - t_w - 2r) = 2 \cdot (2 \cdot 300 - 9,5 - 2 \cdot 27) = 1073 \text{ mm}$$

Proračunska otpornost zavara :

- Uzeta je debljina zavara od 10 mm.

$$F_{w,Rd} = \frac{\frac{f_u}{\sqrt{3} \cdot \beta_w} \cdot a \cdot L}{\gamma_{M2}} = \frac{\frac{43,0}{\sqrt{3} \cdot 0,80} \cdot 1,0 \cdot 107,3}{1,25} = 2663,84 \text{ kN}$$

Uvjet nosivosti:

$$\frac{F_{w,Ed}}{F_{w,Rd}} = \frac{202,78}{2663,84} = 0,1 \leq 1$$

8.3. Priključak stupa na temelj

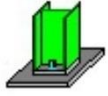

Autodesk Robot Structural Analysis Professional 2022

Pinned column base design

Eurocode 3: EN 1993-1-8:2005/AC:2009 + CEB Design Guide:
Design of fastenings in concrete



Ratio
0,93

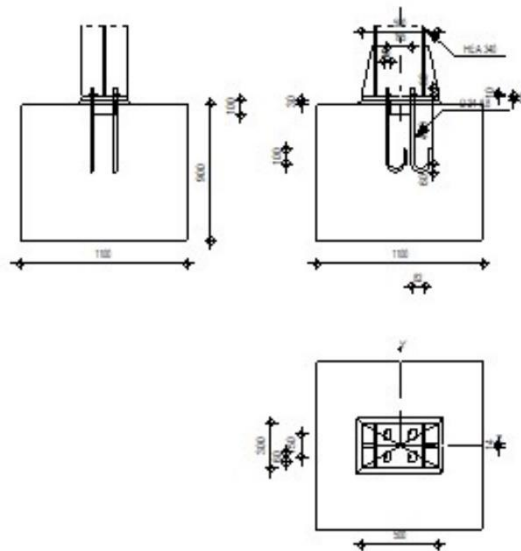

General

Connection no.: 3

Connection name: Temelj

Geometry

Column

Section: HEA 340

$L_c =$	5,00	[m]	Column length
$a =$	0,0	[Deg]	Inclination angle
$h_c =$	330	[mm]	Height of column section
$b_{fc} =$	300	[mm]	Width of column section
$t_{wc} =$	10	[mm]	Thickness of the web of column section
$t_{fc} =$	16	[mm]	Thickness of the flange of column section
$r_c =$	27	[mm]	Radius of column section fillet
$A_c =$	13347	[mm ²]	Cross-sectional area of a column

$L_c = 5,00$ [m] Column length

$I_{yc} = 276931000$ [mm⁴] Moment of inertia of the column section

Material: S 275

$f_{yc} = 275,00$ [MPa] Resistance

$f_{uc} = 430,00$ [MPa] Yield strength of a material

Column base

$l_{pd} = 500$ [mm] Length

$b_{pd} = 300$ [mm] Width

$t_{pd} = 25$ [mm] Thickness

Material: S 275

$f_{ypd} = 275,00$ [MPa] Resistance

$f_{upd} = 430,00$ [MPa] Yield strength of a material

Anchorage

The shear plane passes through the UNTHREADED portion of the bolt.

Class = 8.8 Anchor class

$f_{yb} = 640,00$ [MPa] Yield strength of the anchor material

$f_{ub} = 800,00$ [MPa] Tensile strength of the anchor material

$d = 24$ [mm] Bolt diameter

$A_s = 353$ [mm²] Effective section area of a bolt

$A_v = 452$ [mm²] Area of bolt section

$n_v = 2$ Number of bolt columns

$n_H = 2$ Number of bolt rows

$e_H = 165$ [mm] Horizontal spacing

$e_v = 150$ [mm] Vertical spacing

Anchor dimensions

$L_1 = 50$ [mm]

$L_2 = 450$ [mm]

$L_3 = 120$ [mm]

$L_4 = 100$ [mm]

Washer $l_{wd} = 50$ [mm] Length $b_{wd} = 60$ [mm] Width $t_{wd} = 10$ [mm] Thickness**Wedge**

Section: HEA 160

 $l_w = 100$ [mm] Length

Material: S 275

 $f_{yw} = 275,00$ [MPa] Resistance**Stiffener** $l_s = 500$ [mm] Length $h_s = 330$ [mm] Height $t_s = 14$ [mm] Thickness $d_1 = 20$ [mm] Cut $d_2 = 20$ [mm] Cut**Material factors** $g_{M0} = 1,00$ Partial safety factor $g_{M2} = 1,25$ Partial safety factor $g_c = 1,50$ Partial safety factor**Spread footing** $L = 1100$ [mm] Spread footing length $B = 1100$ [mm] Spread footing width $H = 900$ [mm] Spread footing height**Concrete**

Class C20/25

 $f_{ck} = 20,00$ [MPa] Characteristic resistance for compression**Grout layer** $t_g = 30$ [mm] Thickness of leveling layer (grout) $f_{ck,g} = 12,00$ [MPa] Characteristic resistance for compression

$t_g = 30$ [mm] Thickness of leveling layer (grout)

$C_{f,d} = 0,30$ Coeff. of friction between the base plate and concrete

Welds

$a_p = 7$ [mm] Footing plate of the column base

$a_w = 7$ [mm] Wedge

$a_s = 7$ [mm] Stiffeners

Loads

Case: Manual calculations.

$N_{j,Ed} = -50,19$ [kN] Axial force

$V_{j,Ed,y} = -5,69$ [kN] Shear force

$V_{j,Ed,z} = 432,65$ [kN] Shear force

Results

Compression zone

COMPRESSION OF CONCRETE

$f_{cd} = 13,33$ [MPa] Design compressive resistance EN 1992-1:[3.1.6.(1)]

$f_j = 22,84$ [MPa] Design bearing resistance under the base plate [6.2.5.(7)]

$$c = t_p \cdot \ddot{O}(f_{yp}/(3 \cdot f_j \cdot g_{M0}))$$

$c = 50$ [mm] Additional width of the bearing pressure zone [6.2.5.(4)]

$b_{eff} = 117$ [mm] Effective width of the bearing pressure zone under the flange [6.2.5.(3)]

$l_{eff} = 300$ [mm] Effective length of the bearing pressure zone under the flange [6.2.5.(3)]

$A_{c0} = 35003$ [mm²] Area of the joint between the base plate and the foundation EN 1992-1:[6.7.(3)]

$A_{c1} = 315027$ [mm²] Maximum design area of load distribution EN 1992-1:[6.7.(3)]

$$F_{rd,u} = A_{c0} \cdot f_{cd} \cdot \ddot{O}(A_{c1}/A_{c0}) \leq 3 \cdot A_{c0} \cdot f_{cd}$$

$F_{rd,u} = 1400,12$ [kN] Bearing resistance of concrete EN 1992-1:[6.7.(3)]

$b_j = 0,67$ Reduction factor for compression [6.2.5.(7)]

$$f_{jd} = b_j \cdot F_{rd,u} / (b_{eff} \cdot l_{eff})$$

$f_{jd} = 26,67$ [MPa] Design bearing resistance [6.2.5.(7)]

$A_{c,n} = 99565$ [mm²] Bearing area for compression [6.2.8.2.(1)]

$$F_{c,Rd,i} = A_{c,i} * f_{jd}$$

$$F_{c,Rd,n} = 2655,07 \text{ [kN]} \quad \text{Bearing resistance of concrete for compression [6.2.8.2.(1)]}$$

RESISTANCES OF SPREAD FOOTING IN THE COMPRESSION ZONE

$$N_{j,Rd} = F_{c,Rd,n}$$

$$N_{j,Rd} = 2655,07 \text{ [kN]} \quad \text{Resistance of a spread footing for axial compression [6.2.8.2.(1)]}$$

Connection capacity check

$$N_{j,Ed} / N_{j,Rd} \leq 1,0 \text{ (6.24)} \quad 0,02 < 1,00 \quad \text{verified} \quad (0,02)$$

Shear

BEARING PRESSURE OF AN ANCHOR BOLT ONTO THE BASE PLATE

Shear force $V_{j,Ed,y}$

$$a_{d,y} = 0,9 \quad \text{Coeff. taking account of the bolt position - in the direction of shear} \quad \text{[Table 3.4]}$$

$$a_{b,y} = 0,9 \quad \text{Coeff. for resistance calculation } F_{1,vb,Rd} \quad \text{[Table 3.4]}$$

$$k_{1,y} = 2,5 \quad \text{Coeff. taking account of the bolt position - perpendicularly to the direction of shear} \quad \text{[Table 3.4]}$$

$$F_{1,vb,Rd,y} = k_{1,y} * a_{b,y} * f_{up} * d * t_p / g_{M2}$$

$$F_{1,vb,Rd,y} = 496,15 \text{ [kN]} \quad \text{Resistance of an anchor bolt for bearing pressure onto the base plate [6.2.2.(7)]}$$

Shear force $V_{j,Ed,z}$

$$a_{d,z} = 2,1 \quad \text{Coeff. taking account of the bolt position - in the direction of shear} \quad \text{[Table 3.4]}$$

$$a_{b,z} = 1,0 \quad \text{Coeff. for resistance calculation } F_{1,vb,Rd} \quad \text{[Table 3.4]}$$

$$k_{1,z} = 2,5 \quad \text{Coeff. taking account of the bolt position - perpendicularly to the direction of shear} \quad \text{[Table 3.4]}$$

$$F_{1,vb,Rd,z} = k_{1,z} * a_{b,z} * f_{up} * d * t_p / g_{M2}$$

$$F_{1,vb,Rd,z} = 516,00 \text{ [kN]} \quad \text{Resistance of an anchor bolt for bearing pressure onto the base plate [6.2.2.(7)]}$$

SHEAR OF AN ANCHOR BOLT

$$a_b = 0,25 \quad \text{Coeff. for resistance calculation } F_{2,vb,Rd} \quad \text{[6.2.2.(7)]}$$

$$A_{vb} = 452 \text{ [mm}^2\text{]} \quad \text{Area of bolt section} \quad \text{[6.2.2.(7)]}$$

$$f_{ub} = 800,00 \text{ [MPa]} \quad \text{Tensile strength of the anchor material} \quad \text{[6.2.2.(7)]}$$

SHEAR OF AN ANCHOR BOLT

$a_b = 0,25$ Coeff. for resistance calculation $F_{2,vb,Rd}$ [6.2.2.(7)]

$g_{M2} = 1,25$ Partial safety factor [6.2.2.(7)]

$$F_{2,vb,Rd} = a_b * f_{ub} * A_{vb} / g_{M2}$$

$F_{2,vb,Rd} = 71,80$ [kN] Shear resistance of a bolt - without lever arm [6.2.2.(7)]

$a_M = 2,00$ Factor related to the fastening of an anchor in the foundation CEB [9.3.2.2]

$M_{Rk,s} = 1,30$ [kN*m] Characteristic bending resistance of an anchor CEB [9.3.2.2]

$l_{sm} = 54$ [mm] Lever arm length CEB [9.3.2.2]

$g_{Ms} = 1,20$ Partial safety factor CEB [3.2.3.2]

$$F_{v,Rd,sm} = a_M * M_{Rk,s} / (l_{sm} * g_{Ms})$$

$F_{v,Rd,sm} = 39,84$ [kN] Shear resistance of a bolt - with lever arm CEB [9.3.1]

CONCRETE PRY-OUT FAILURE

$N_{Rk,c} = 186,63$ [kN] Design uplift capacity CEB [9.2.4]

$k_3 = 2,00$ Factor related to the anchor length CEB [9.3.3]

$g_{Mc} = 2,16$ Partial safety factor CEB [3.2.3.1]

$$F_{v,Rd,cp} = k_3 * N_{Rk,c} / g_{Mc}$$

$F_{v,Rd,cp} = 172,80$ [kN] Concrete resistance for pry-out failure CEB [9.3.1]

CONCRETE EDGE FAILURE**Shear force $V_{j,Ed,y}$**

$V_{Rk,c,y}^0 = 250,42$ [kN] Characteristic resistance of an anchor CEB [9.3.4.(a)]

$y_{A,V,y} = 0,66$ Factor related to anchor spacing and edge distance CEB [9.3.4]

$y_{h,V,y} = 1,00$ Factor related to the foundation thickness CEB [9.3.4.(c)]

$y_{s,V,y} = 0,90$ Factor related to the influence of edges parallel to the shear load direction CEB [9.3.4.(d)]

$V_{Rk,c,y}^0 = 250,42$ [kN]	Characteristic resistance of an anchor	CEB [9.3.4.(a)]
$\gamma_{ec,v,y} = 1,00$	Factor taking account a group effect when different shear loads are acting on the individual anchors in a group	CEB [9.3.4.(e)]
$\gamma_{a,v,y} = 1,00$	Factor related to the angle at which the shear load is applied	CEB [9.3.4.(f)]
$\gamma_{ucr,v,y} = 1,00$	Factor related to the type of edge reinforcement used	CEB [9.3.4.(g)]
$g_{Mc} = 2,16$	Partial safety factor	CEB [3.2.3.1]

$$F_{v,Rd,c,y} = \frac{V_{Rk,c,y}^0 * \gamma_{A,v,y} * \gamma_{h,v,y} * \gamma_{s,v,y} * \gamma_{ec,v,y} * \gamma_{a,v,y} * \gamma_{ucr,v,y}}{g_{Mc}}$$

$$F_{v,Rd,c,y} = 68,22 \text{ [kN]} \quad \text{Concrete resistance for edge failure} \quad \text{CEB [9.3.1]}$$

Shear force $V_{j,Ed,z}$

$V_{Rk,c,z}^0 = 244, [k$ $= 51 \text{ N}]$	Characteristic resistance of an anchor	CEB [9.3.4.(a)]
$\gamma_{A,v,z} = 0,68$	Factor related to anchor spacing and edge distance	CEB [9.3.4]
$\gamma_{h,v,z} = 1,00$	Factor related to the foundation thickness	CEB [9.3.4.(c)]
$\gamma_{s,v,z} = 0,90$	Factor related to the influence of edges parallel to the shear load direction	CEB [9.3.4.(d)]
$\gamma_{ec,v,z} = 1,00$	Factor taking account a group effect when different shear loads are acting on the individual anchors in a group	CEB [9.3.4.(e)]
$\gamma_{a,v,z} = 1,00$	Factor related to the angle at which the shear load is applied	CEB [9.3.4.(f)]
$\gamma_{ucr,v,z} = 1,00$	Factor related to the type of edge reinforcement used	CEB [9.3.4.(g)]
$g_{Mc} = 2,16$	Partial safety factor	CEB [3.2.3.1]

$$F_{v,Rd,c,z} = V_{Rk,c,z} \cdot \gamma_{A,v,z} \cdot \gamma_{h,v,z} \cdot \gamma_{s,v,z} \cdot \gamma_{ec,v,z} \cdot \gamma_{a,v,z} \cdot \gamma_{ucr,v,z} / g_{Mc}$$

$$F_{v,Rd,c,z} = 69,25 \text{ [kN]} \quad \text{Concrete resistance for edge failure} \quad \text{CEB [9.3.1]}$$

SPLITTING RESISTANCE

$$C_{f,d} = 0,30 \quad \text{Coeff. of friction between the base plate and concrete [6.2.2.(6)]}$$

$$N_{c,Ed} = 50,19 \text{ [kN]} \quad \text{Compressive force} \quad [6.2.2.(6)]$$

$$F_{f,Rd} = C_{f,d} \cdot N_{c,Ed}$$

$$F_{f,Rd} = 15,06 \text{ [kN]} \quad \text{Slip resistance} \quad [6.2.2.(6)]$$

BEARING PRESSURE OF THE WEDGE ONTO CONCRETE

$$F_{v,Rd,wg,y} = 1.4 \cdot l_w \cdot b_{wy} \cdot f_{ck} / g_c$$

$$F_{v,Rd,wg,y} = 283,73 \text{ [kN]} \quad \text{Resistance for bearing pressure of the wedge onto concrete}$$

$$F_{v,Rd,wg,z} = 1.4 \cdot l_w \cdot b_{wz} \cdot f_{ck} / g_c$$

$$F_{v,Rd,wg,z} = 298,67 \text{ [kN]} \quad \text{Resistance for bearing pressure of the wedge onto concrete}$$

SHEAR CHECK

$$V_{j,Rd,y} = n_b \cdot \min(F_{1,vb,Rd,y}, F_{2,vb,Rd}, F_{v,Rd,sm}, F_{v,Rd,cp}, F_{v,Rd,c,y}) + F_{v,Rd,wg,y} + F_{f,Rd}$$

$$V_{j,Rd,y} = 458,16 \text{ [kN]} \quad \text{Connection resistance for shear} \quad \text{CEB [9.3.1]}$$

$$V_{j,Ed,y} / V_{j,Rd,y} \leq 1,0 \quad 0,01 < 1,00 \quad \text{verified} \quad (0,01)$$

$$V_{j,Rd,z} = n_b \cdot \min(F_{1,vb,Rd,z}, F_{2,vb,Rd}, F_{v,Rd,sm}, F_{v,Rd,cp}, F_{v,Rd,c,z}) + F_{v,Rd,wg,z} + F_{f,Rd}$$

$$V_{j,Rd,z} = 473,10 \text{ [kN]} \quad \text{Connection resistance for shear} \quad \text{CEB [9.3.1]}$$

$$V_{j,Ed,z} / V_{j,Rd,z} \leq 1,0 \quad 0,91 < 1,00 \quad \text{verified} \quad (0,91)$$

$$V_{j,Ed,y} / V_{j,Rd,y} + V_{j,Ed,z} / V_{j,Rd,z} \leq 1,0 \quad 0,93 < 1,00 \quad \text{verified} \quad (0,93)$$

Stiffener check

Stiffener parallel to the web (along the extension of the column web)

$$M_1 = 0,21 \text{ [kN} \cdot \text{m]} \quad \text{Bending moment acting on a stiffener}$$

$$Q_1 = 4,89 \text{ [kN]} \quad \text{Shear force acting on a stiffener}$$

$$z_s = 80 \text{ [mm]} \quad \text{Location of the neutral axis (from the plate base)}$$

$$I_s = \frac{1323906}{86} \text{ [mm}^4\text{]} \quad \text{Moment of inertia of a stiffener}$$

Stiffener parallel to the web (along the extension of the column web)

$M_1 = 0,21$	[kN* m]	Bending moment acting on a stiffener	
$s_d = 0,09$	[MPa]	Normal stress on the contact surface between stiffener and plate	EN 1993-1-1:[6.2.1.(5)]
$s_g = 0,43$	[MPa]	Normal stress in upper fibers	EN 1993-1-1:[6.2.1.(5)]
$t = 1,06$	[MPa]	Tangent stress in a stiffener	EN 1993-1-1:[6.2.1.(5)]
$s_z = 1,84$	[MPa]	Equivalent stress on the contact surface between stiffener and plate	EN 1993-1-1:[6.2.1.(5)]

$$\max(s_g, t / (0.58), s_z) / (f_{yp}/g_{M0}) \leq 1.0 \quad (6.1) \quad 0,01 < 1,00 \quad \text{verified} \quad (0,01)$$

Welds between the column and the base plate

$s_\wedge = 1,80$	[MPa]	Normal stress in a weld	[4.5.3.(7)]
$t_\wedge = 1,80$	[MPa]	Perpendicular tangent stress	[4.5.3.(7)]
$t_{yII} = -0,69$	[MPa]	Tangent stress parallel to $V_{j,Ed,y}$	[4.5.3.(7)]
$t_{zII} = 66,17$	[MPa]	Tangent stress parallel to $V_{j,Ed,z}$	[4.5.3.(7)]
$b_w = 0,85$		Resistance-dependent coefficient	[4.5.3.(7)]

$$s_\wedge / (0.9 * f_u / g_{M2}) \leq 1.0 \quad (4.1) \quad 0,01 < 1,00 \quad \text{verified} \quad (0,01)$$

$$\ddot{O}(s_\wedge^2 + 3.0 (t_{yII}^2 + t_\wedge^2)) / (f_u / (b_w * g_{M2})) \leq 1.0 \quad (4.1) \quad 0,01 < 1,00 \quad \text{verified} \quad (0,01)$$

$$\ddot{O}(s_\wedge^2 + 3.0 (t_{zII}^2 + t_\wedge^2)) / (f_u / (b_w * g_{M2})) \leq 1.0 \quad (4.1) \quad 0,28 < 1,00 \quad \text{verified} \quad (0,28)$$

Vertical welds of stiffeners**Stiffener parallel to the web (along the extension of the column web)**

$s_\wedge = 0,58$	[MPa]	Normal stress in a weld	[4.5.3.(7)]
$t_\wedge = 0,58$	[MPa]	Perpendicular tangent stress	[4.5.3.(7)]
$t_{II} = 1,06$	[MPa]	Parallel tangent stress	[4.5.3.(7)]
$s_z = 2,17$	[MPa]	Total equivalent stress	[4.5.3.(7)]
$b_w = 0,85$		Resistance-dependent coefficient	[4.5.3.(7)]

$$\max(s_\wedge, t_{II} * \ddot{O}3, s_z) / (f_u / (b_w * g_{M2})) \leq 1.0 \quad (4.1) \quad 0,01 < 1,00 \quad \text{verified} \quad (0,01)$$

Transversal welds of stiffeners**Stiffener parallel to the web (along the extension of the column web)**

s^{\wedge} =	2,91	[MPa]	Normal stress in a weld	[4.5.3.(7)]
t_{\perp} =	2,91	[MPa]	Perpendicular tangent stress	[4.5.3.(7)]
$t_{ }$ =	0,65	[MPa]	Parallel tangent stress	[4.5.3.(7)]
s_z =	5,92	[MPa]	Total equivalent stress	[4.5.3.(7)]
b_w =	0,85		Resistance-dependent coefficient	[4.5.3.(7)]

$$\max (s^{\wedge}, t_{||} * \sqrt{3}, s_z) / (f_u / (b_w * g_{M2})) \leq 1.0 \quad (4.1) \quad 0,01 < 1,00 \quad \text{verified (0,01)}$$

Weakest component:

FOUNDATION - BEARING PRESSURE ONTO CONCRETE

Remarks

Anchor curvature radius is too small. 60 [mm] < 72 [mm]

Segment L4 of the hook anchor is too short. 100 [mm] < 120 [mm]

Connection conforms to the code

Ratio 0,93

$$V_{Ed} = 50,19 \text{ kN}$$

$$N_{Ed} = 432,65 \text{ kN} \quad (\text{tlak})$$

Proračun vijaka

Vijci: M24 - k.v. 8.8.

$$\text{Granica popuštanja: } f_{yb} = 640 \text{ N/mm}^2$$

$$\text{Vlačna čvrstoća: } f_{ub} = 800 \text{ N/mm}^2$$

$$\text{Promjer jezgre vijka: } d = 24 \text{ mm}$$

$$\text{Promjer rupe za vijak: } d_0 = 26 \text{ mm}$$

$$\text{Vlačna površina pop. presjeka vijka: } A_s = 353 \text{ mm}^2$$

Čelična ploča: S275 t = 25 mm

$$\text{Vlačna čvrstoća: } f_u = 430 \text{ N/mm}^2$$

Otpornost vijaka na posmik

Otpornost jednog vijka opterećenog na posmik:

$$F_{v,Rd} = \frac{\alpha_v \cdot f_{ub} \cdot A_s}{\gamma_{M2}}$$

$$\alpha_v = 0,6$$

$$F_{v,Rd} = \frac{0,6 \cdot 800 \cdot 353}{1,25} = 135,55 \text{ kN}$$

$$F_{v,Rd} = 135,55 \cdot 4 = 542,21 \text{ kN}$$

Uvjet nosivosti:

$$F_{v,Ed} \leq F_{v,Rd}$$

$$50,19 \text{ kN} < 444,68 \text{ kN} \quad (69\%)$$

Otpornost na pritisak po omotaču rupe osnovnog materijala

$$e_1 = \frac{l_{pd}}{2} = \frac{500}{2} = 250 \text{ mm}$$

$$e_2 = \frac{b_{pd} - e_v}{2} = \frac{300 - 150}{2} = 75 \text{ mm}$$

Promjer vijka: $d = 24 \text{ mm}$

Promjer rupe za vijak: $d_0 = 26 \text{ mm}$

Debljina čelične ploče: $t = 25 \text{ mm}$

Otpornost na pritisak po omotaču rupe jednog vijka:

$$\alpha_d = \frac{e_1}{3 \cdot d_0} = \frac{250}{3 \cdot 26} = 3,21$$

$$\alpha_b = \min\left(\alpha_d; \frac{f_{ub}}{f_u}; 1\right) = \min\left(3,21; \frac{800}{430}; 1\right) = 1$$

$$k_1 = \min\left(2,8 \cdot \frac{e_2}{d_0} - 1,7; 2,5\right) = \min\left(2,8 \cdot \frac{75}{26} - 1,7; 2,5\right) = 2,5$$

$$F_{b,Rd} = \frac{k_1 \cdot \alpha_b \cdot f_{ub} \cdot d \cdot t}{\gamma_{M2}}$$

$$F_{b,Rd} = \frac{2,5 \cdot 1 \cdot 430 \cdot 24 \cdot 25}{1,25} = 516 \text{ kN}$$

Uvjet nosivosti:

$$F_{v,Ed} \leq F_{b,Rd}$$

$$432,65 \text{ kN} < 516 \text{ kN} \text{ (84\%)}$$

Proračun zavar

Djelovanje na zavar: $F_{w,Ed} = V_{z,Ed} = 50,19 \text{ kN}$

Duljina zavar:

$$L = 2 \cdot (2b - t_w - 2r) = 2 \cdot (2 \cdot 300 - 9,5 - 2 \cdot 27) = 1073 \text{ mm}$$

Proračunska otpornost zavar :

- Uzeta je debljina zavar od 6 mm.

$$F_{w,Rd} = \frac{\frac{f_u}{\sqrt{3} \cdot \beta_w} \cdot a \cdot L}{\gamma_{M2}} = \frac{43,0}{\sqrt{3} \cdot 0,80} \cdot 0,6 \cdot 107,3}{1,25} = 1598,30 \text{ kN}$$

Uvjet nosivosti:

$$\frac{F_{w,Ed}}{F_{w,Rd}} \leq 1$$

$$\frac{50,19}{1598,30} = 0,03 < 1$$

9. Zaključak

U ovom diplomskom radu provedena je analiza i dimenzioniranje elemenata čelične konstrukcije proizvodnog pogona smještenog u Puli. Proračun je proveden u skladu s Eurocode normama i pripadajućim Nacionalnim dodacima.

S obzirom da su u hali predviđene dvije dizalice različitih nosivosti, u projektiranje se krenulo prilagođavanjem gabarita, dimenzija i potrebne visine konstrukcije za nesmetano prometovanje već gotovih i spremnih dizalica za ugradnju i rad. Dizalice su nosivosti 5 i 16 tona koje prometuju po kranskim stazama koje su oslonjene na konzole pričvršćene na stupove hale.

Konstrukcija se sastoji od 11 okvira. Projektom nije predviđeno nastavljanje i proširenje konstrukcije jednog dana tako da su za zabatne okvire izabrani drugačiji profili stupova i grednih nosača nego li u ostalim okvirima u sredini hale. Na čelima hale su izabrani profili IPE 330, dok su u unutrašnjim okvirima HEA 340, ali pritom se pazilo na to da profili imaju istu visinu ($h = 330$ mm) kako bi se omogućila lakša montaža horizontalnih nosača obloge i fasade.

Statička analiza, dimenzioniranje elemenata i priključaka konstrukcije provedena je u programu Autodesk Robot Structural Analysis na 3D modelu sukladno normi Eurocode 3, te stupovi i gredni nosači ručno provjereni. Pri dimenzioniranju elemenata, svaki element konstrukcije zadovoljio je zahtjeve stabilnosti i mehaničke otpornosti u graničnom stanju nosivosti GSN i graničnom stanju uporabivosti GSU. Također, radi racionalizacije troškova, birani su profili veće zadovoljivosti. U nekim slučajevima moguće je još povećanje iskoristivosti odabirom manjih profila, a ujedno smanjenjem troškova.

U Tablici 23. prikazane su iskoristivosti elemenata i spojeva:

Tablica 23. Iskoristivosti elemenata i spojeva [izradio autor]

Element	Profil	Materijal	Iskoristivost
Vanjski stupovi	HEA 340	S 275	64%
Vanjski zabatni stupovi	IPE 330	S 275	41%
Unutarnji stupovi	HEA 340	S 275	89%
Unutarnji zabatni stupovi	IPE 330	S 275	46%
Gredni nosači	HEA 340	S 275	67%
Gredni zabatni nosači	IPE 330	S 275	27%
Podrožnice	IPE 270	S 275	69%
Zabatni stupovi	IPE 330	S 275	77%
Krovni uzdužni vezovi	Okrugli puni profil 25 mm	S 275	87%
Krovni poprečni vezovi	Okrugli puni profil 25 mm	S 275	85%
Vertikalni uzdužni vezovi	Okrugli puni profil 25 mm	S 275	47%
Vertikalni poprečni vezovi	Okrugli puni profil 25 mm	S 275	71%
Horizontalni zabatni nosači obloge	UPN 240	S 275	82%
Horizontalni uzdužni nosači obloge	UPN 240	S 275	87%
Konzole	IPE 300	S 275	80%
Kranska staza	HEA 280	S 275	72%
Detalj A, spoj stupa na temelj			77%
Detalj B, spoj stupa i grednog nosača			95%
Detalj C, spoj grednih nosača u sljemenu			93%

10. Literatura

- [1] <https://www.trimo-group.com/hr/proizvodi/krovovi/trimoterm-1>
- [2] HRN EN 1991-1-3:2012/NA, Eurokod 1: Djelovanja na konstrukcije - Dio 1-3: Opća djelovanja – Opterećenje snijegom
- [3] Dujmović, D., Androić, B., Džeba, I., *Modeliranje konstrukcija prema Eurocode 3*, IA Projektiranje, Zagreb, 2004
- [4] HRN EN 1991-1-4:2012/NA, Eurokod 1: Djelovanja na konstrukcije - Dio 1-4: Opća djelovanja – Djelovanja vjetra
- [5] <https://hoistec.hr/>
- [6] HRN EN 1993-1-1, Eurokod 3: Projektiranje čeličnih konstrukcija - Dio 1-1: Opća pravila i pravila za građevine, Brisel, 2005.
- [7] HRN EN 1993-1-8, Eurokod 3: Projektiranje čeličnih konstrukcija - Dio 1-8: Proračun priključaka, Brisel, 2005.
- [8] Androić, B., Dujmović, D., Džeba, I., *Čelične konstrukcije 1*, IA Projektiranje, Zagreb, 2009.
- [9] Androić, B., Dujmović, D., Džeba, I., *Čelične konstrukcije 2*, IA Projektiranje, Zagreb, 2007.
- [10] Nastavni materijali

NACRTI

DISPOZICIJA

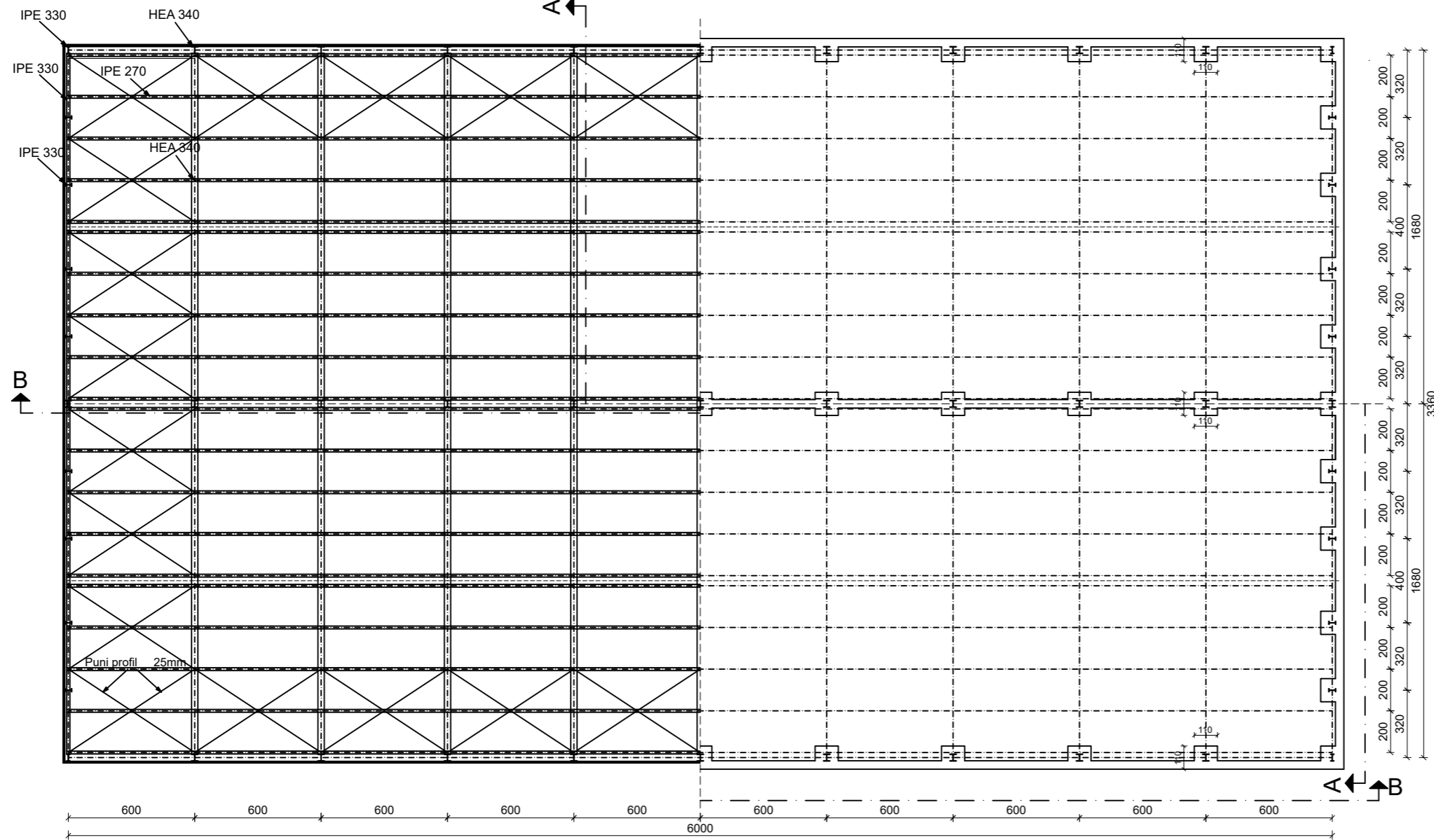

POPREČNI PRESJEK A-A

POGLED A-A

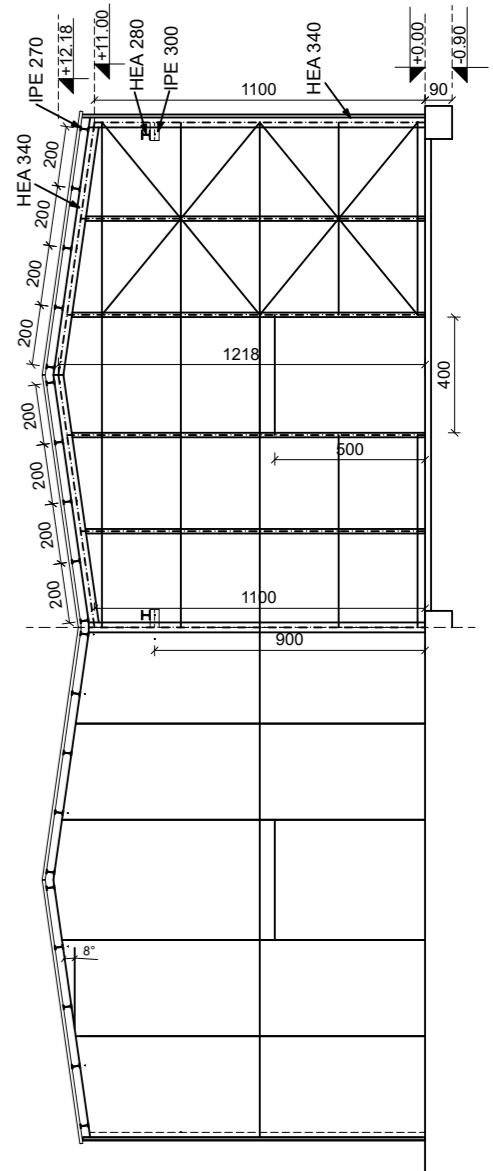

UZDUŽNI PRESJEK B-B

POGLED B-B

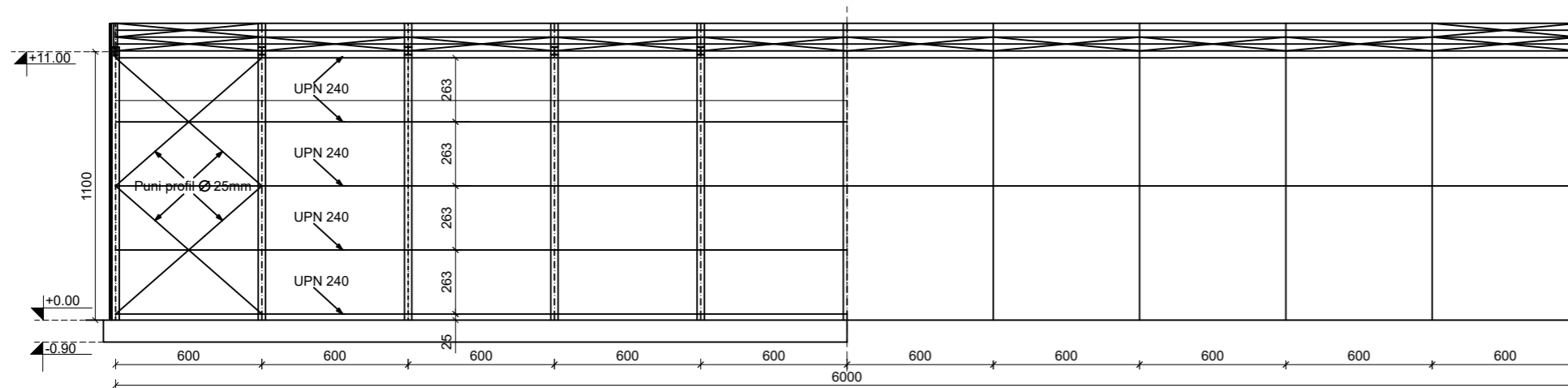

 GRAĐEVINSKI FAKULTET SVEUČILIŠTA U RIJECI			
Diplomski rad:		Sadržaj nacрта:	
Dimenzioniranje čelične konstrukcije proizvodnog pogona		DISPOZICIJA	
Kolegij:		Kolegij:	
Marin Ivković		Čelične konstrukcije	
Mentor:	Datum:	Mjerilo:	List:
Izv.prof.dr.sc. Mladen Bulić dipl.ing.građ.	11.09.2023.	1:250	1

PLAN POZICIJA

PRESJEK B-B

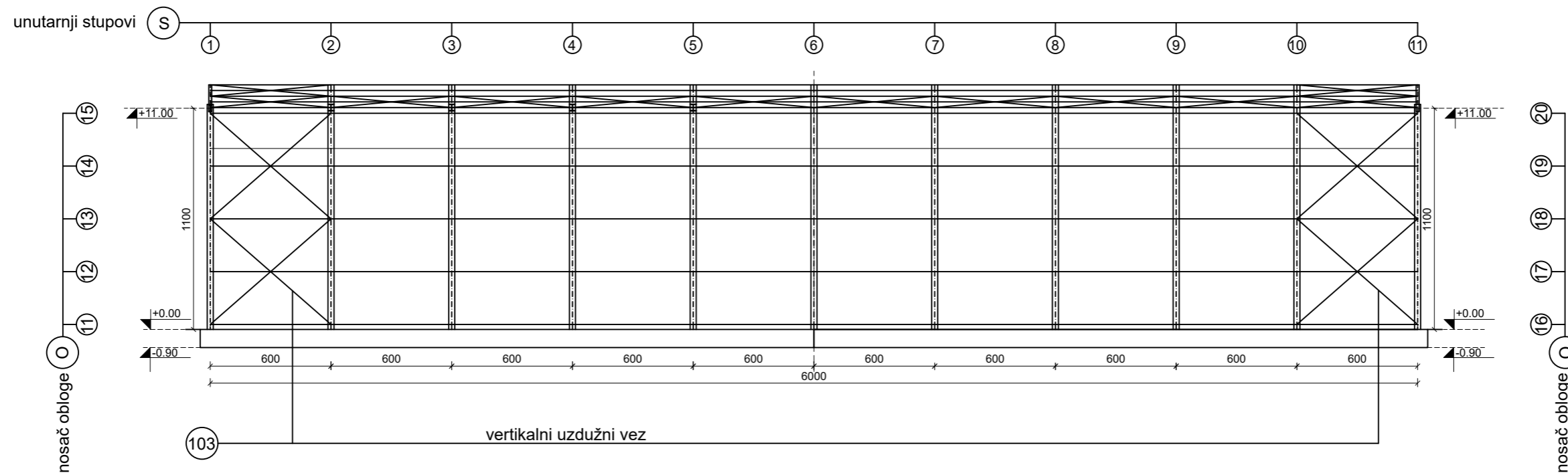

PRESJEK A-A

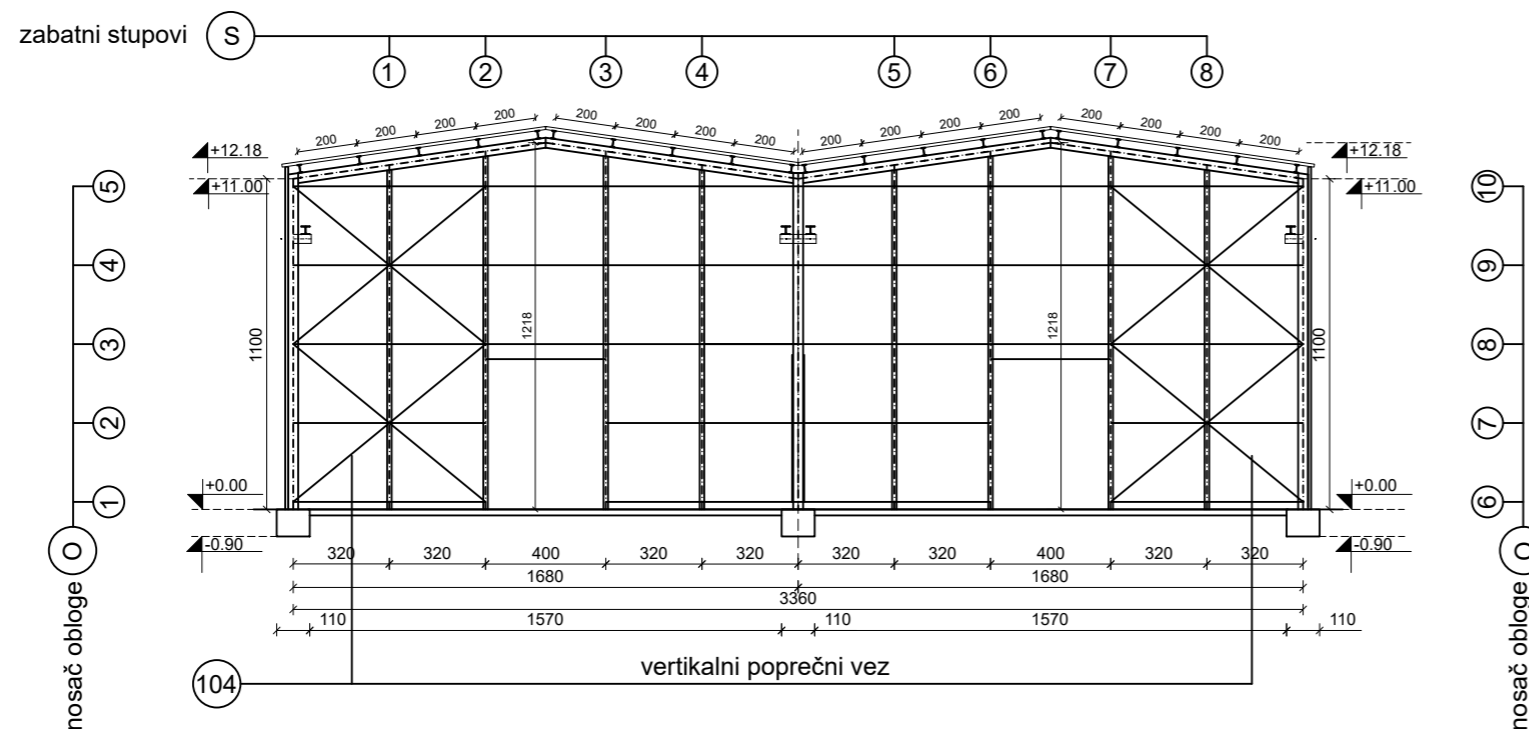

 GRAĐEVINSKI FAKULTET SVEUČILIŠTA U RIJECI			
Diplomski rad:		Sadržaj nacrt:	
Dimenzioniranje čelične konstrukcije proizvodnog pogona		PLAN POZICIJA PRESJEK A-A PRESJEK B-B	
Kolegij:		Kolegij:	
Marin Ivković		Čelične konstrukcije	
Mentor:	Datum:	Mjerilo:	List:
Izv.prof.dr.sc. Mladen Bulić dipl.ing.građ.	11.09.2023.	1:250	3

PRIKLJUČAK STUPA NA TEMELJ
(DETALJ A) M 1:10

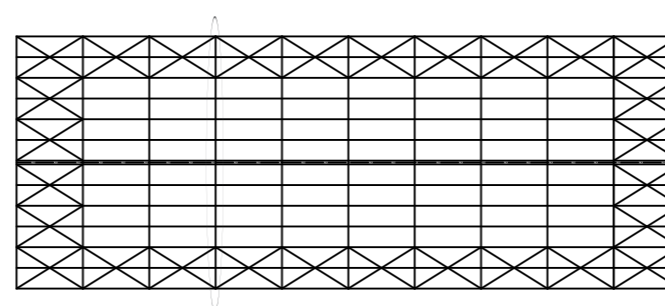
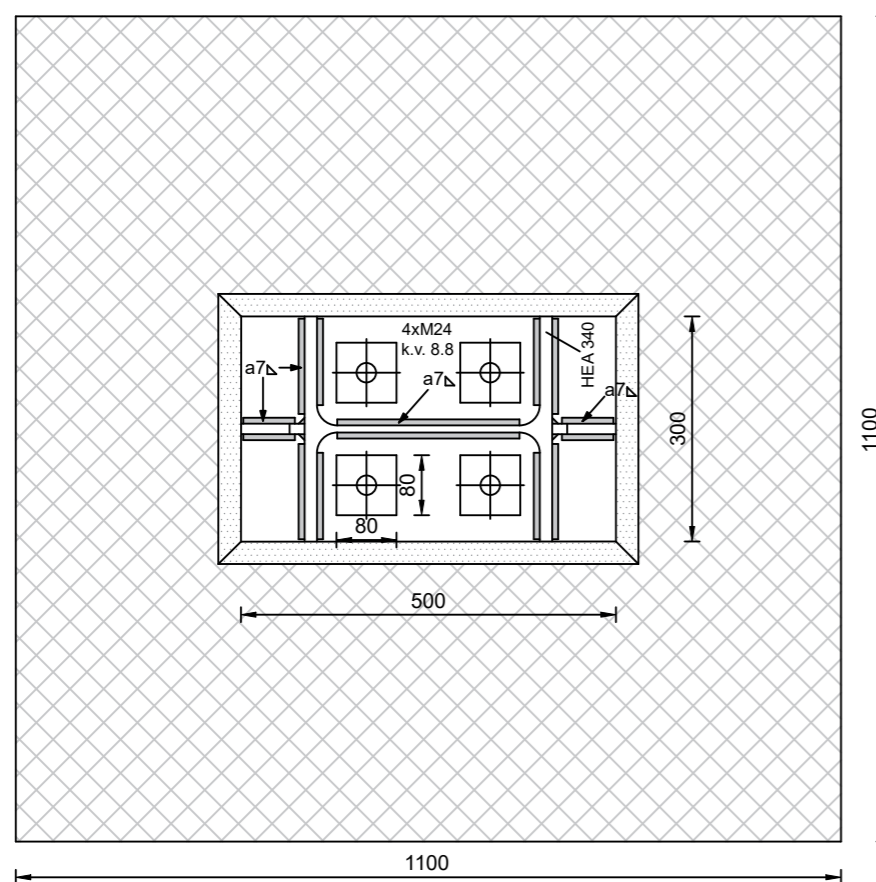
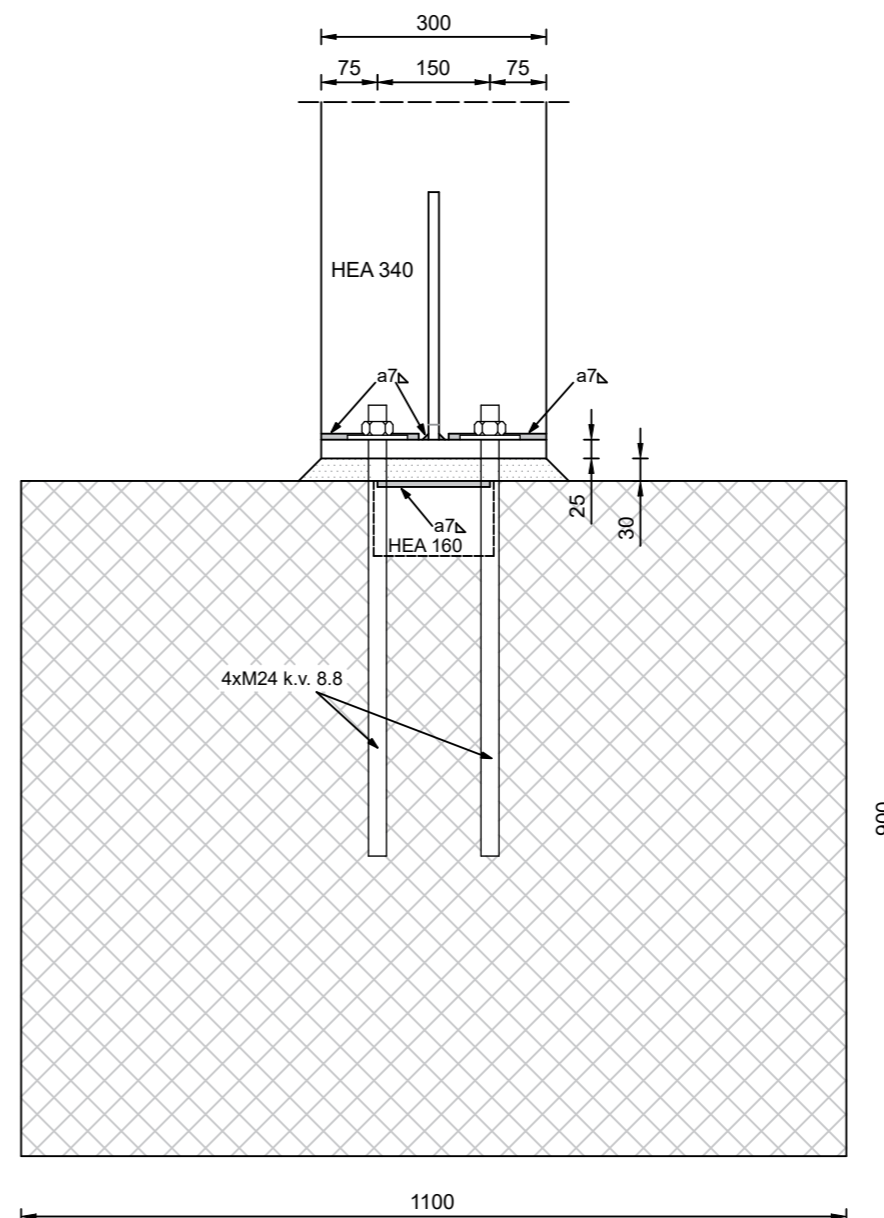
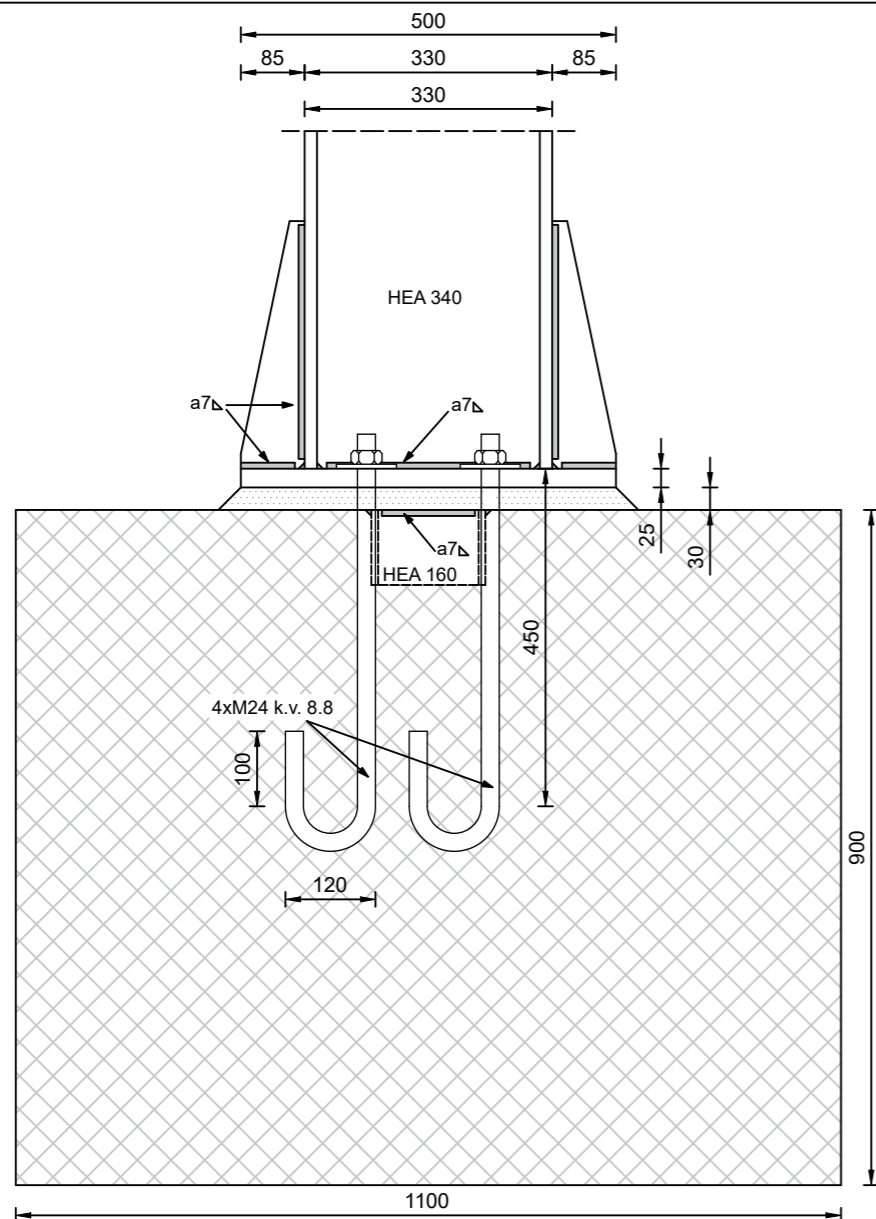

G E GRAĐEVINSKI FAKULTET SVEUČILIŠTA U RIJECI			
Diplomski rad:		Sadržaj nacrt:	
Dimenzioniranje čelične konstrukcije proizvodnog pogona		Priključak stupa na temelj (detalj A)	
Kolegij:		Kolegij:	
Marin Ivković		Čelične konstrukcije	
Mentor:	Izv.prof.dr.sc. Mladen Bulić dipl.ing.građ.	Datum:	Mjerilo:
		11.09.2023.	1:10
		List:	4

PRIKLJUČAK STUPA I GREдноG NOSAČA (DETALJ B) M 1:10

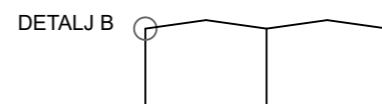
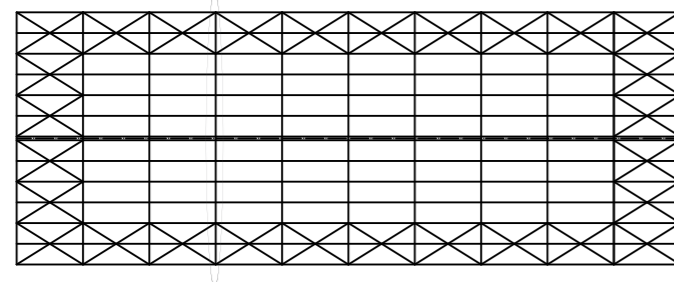
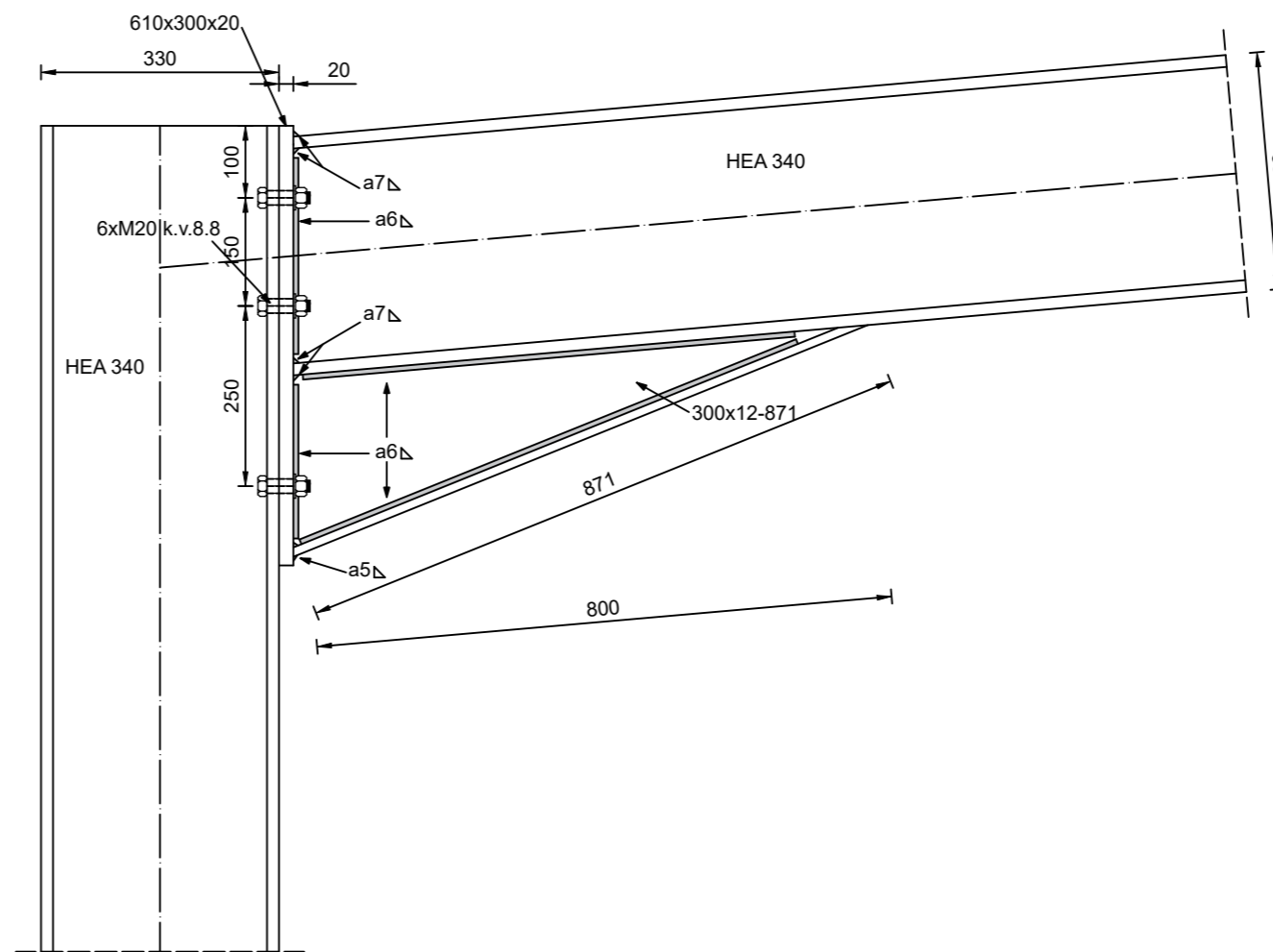
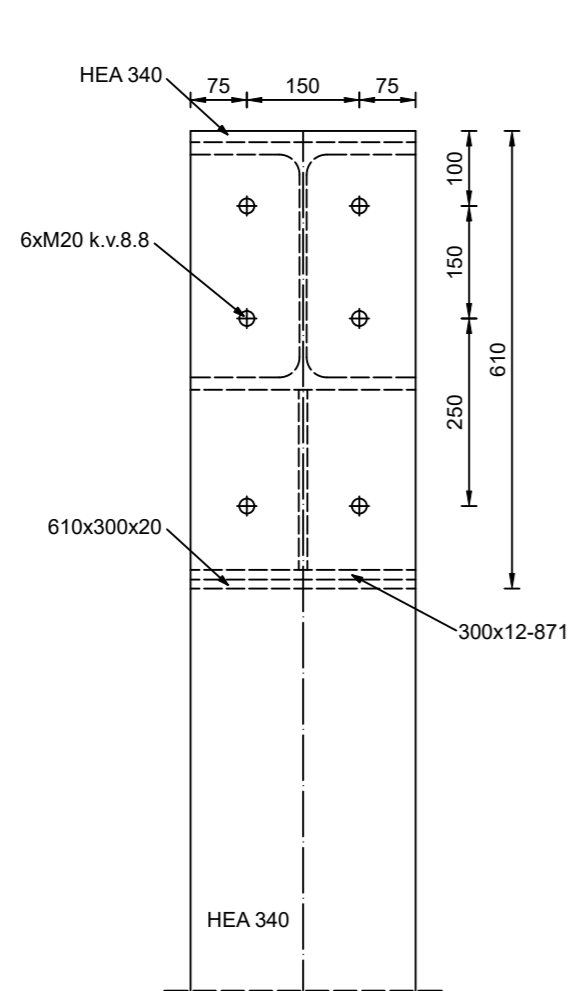
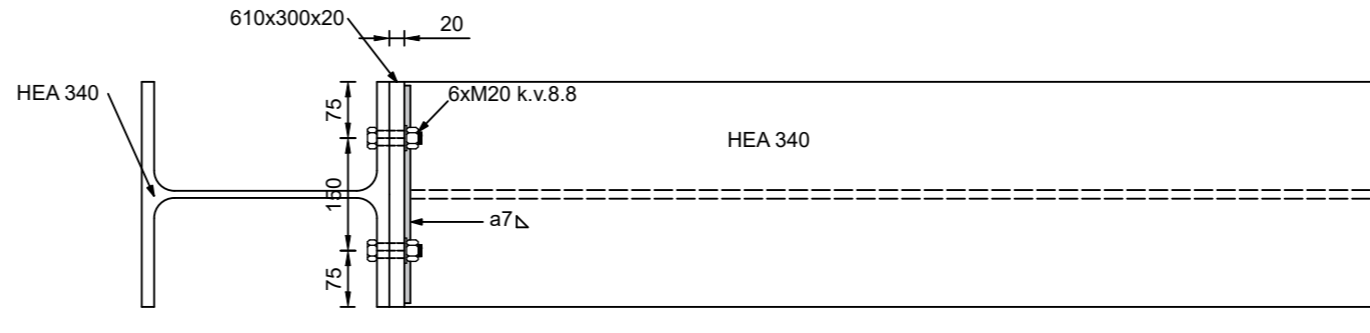

 GRAĐEVINSKI FAKULTET SVEUČILIŠTA U RIJECI			
Diplomski rad:		Sadržaj nacрта:	
Dimenzioniranje čelične konstrukcije proizvodnog pogona		Priključak stupa i grednog nosača (detalj B)	
Kolegij:		Kolegij:	
Marin Ivković		Čelične konstrukcije	
Mentor:	Izv.prof.dr.sc. Mladen Bulić dipl.ing.građ.	Datum:	Mjerilo:
		11.09.2023.	1:10
			List:
			5

PRIKLJUČAK NOSAČA U SLJEMENU (DETALJ C) M 1:5

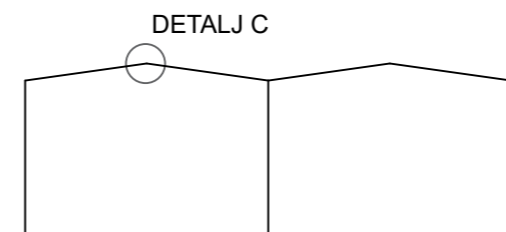
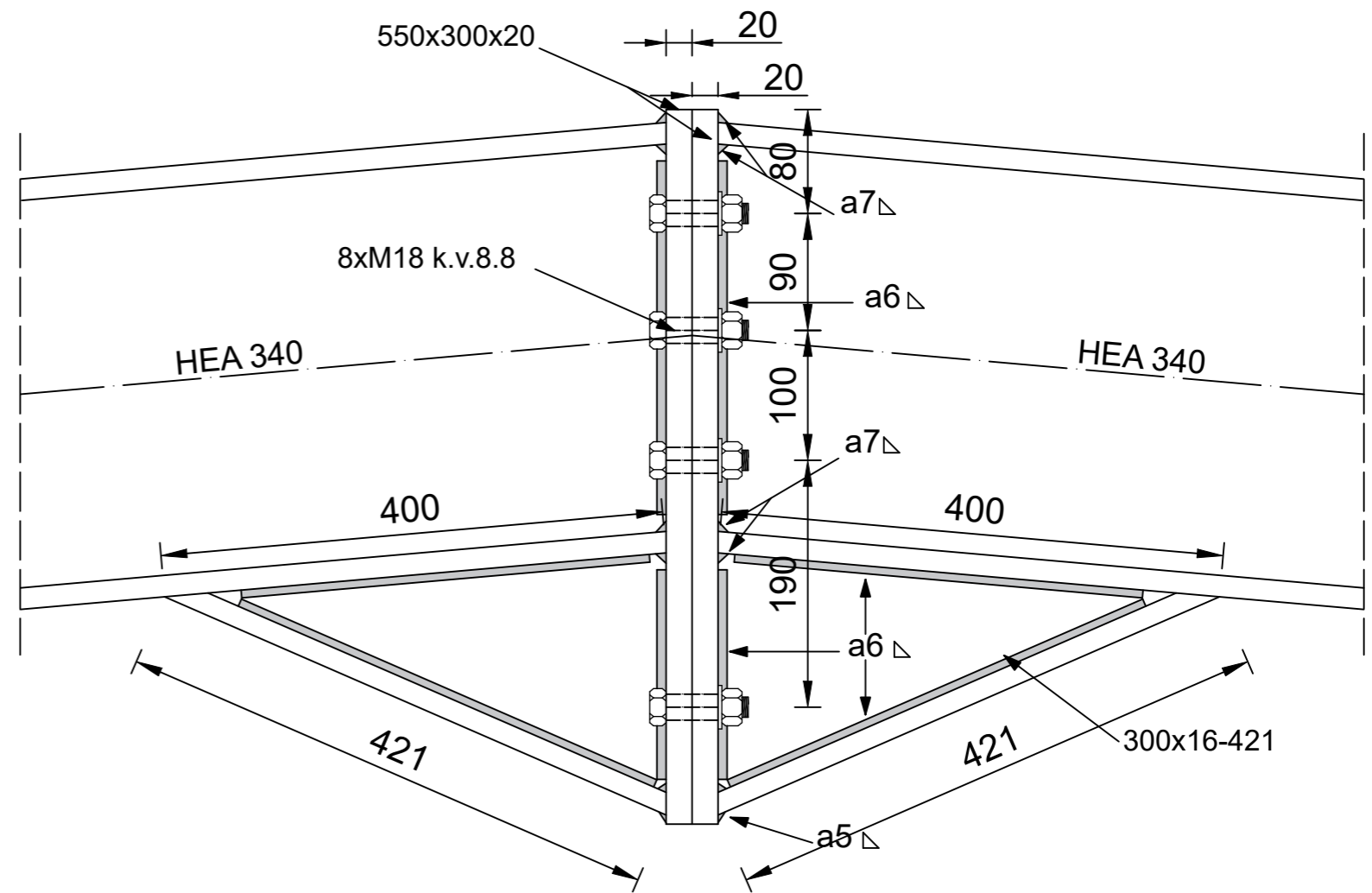
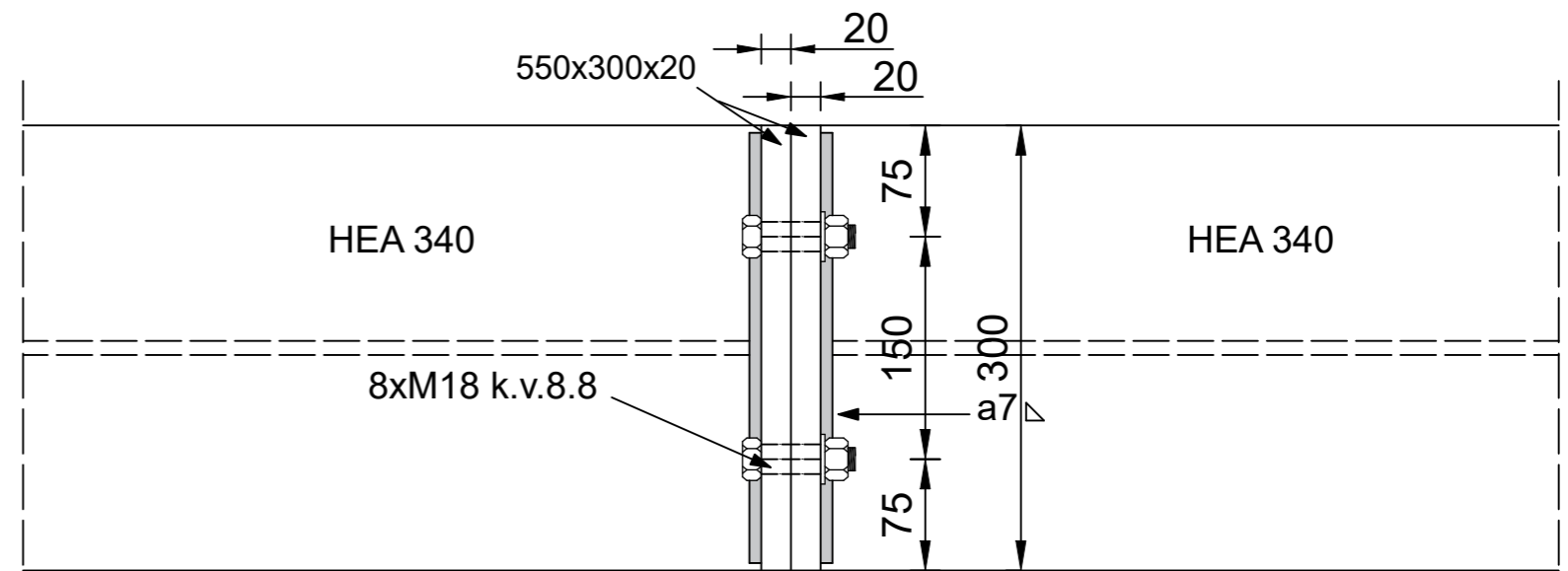
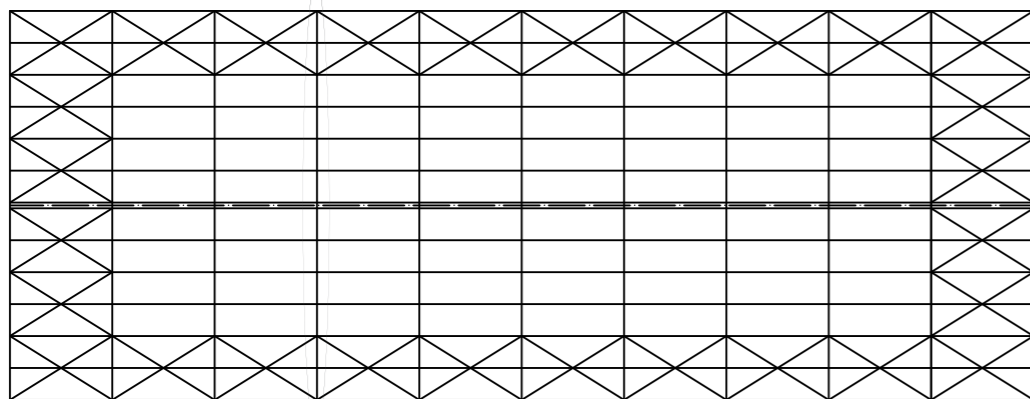
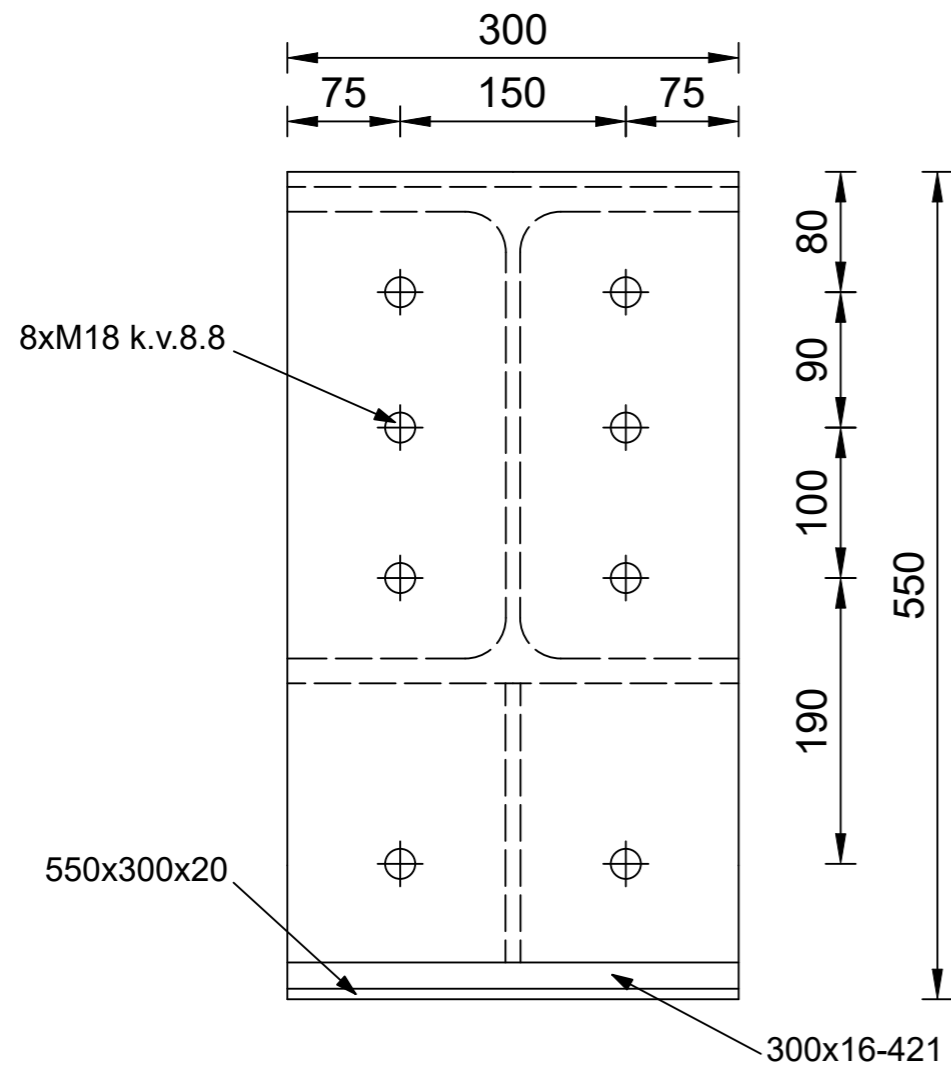

 GRAĐEVINSKI FAKULTET SVEUČILIŠTA U RIJECI			
Diplomski rad:		Sadržaj nacrt:	
Dimenzioniranje čelične konstrukcije proizvodnog pogona		Priključak nosača u sljemenu (detalj C)	
Kolegij:		Kolegij:	
Marin Ivković		Čelične konstrukcije	
Mentor:	Izv.prof.dr.sc. Mladen Bulić dipl.ing.građ.	Datum:	11.09.2023.
		Mjerilo:	1:5
		List:	6

RADIONIČKI NACRT, PORTALNI OKVIR M 1:25

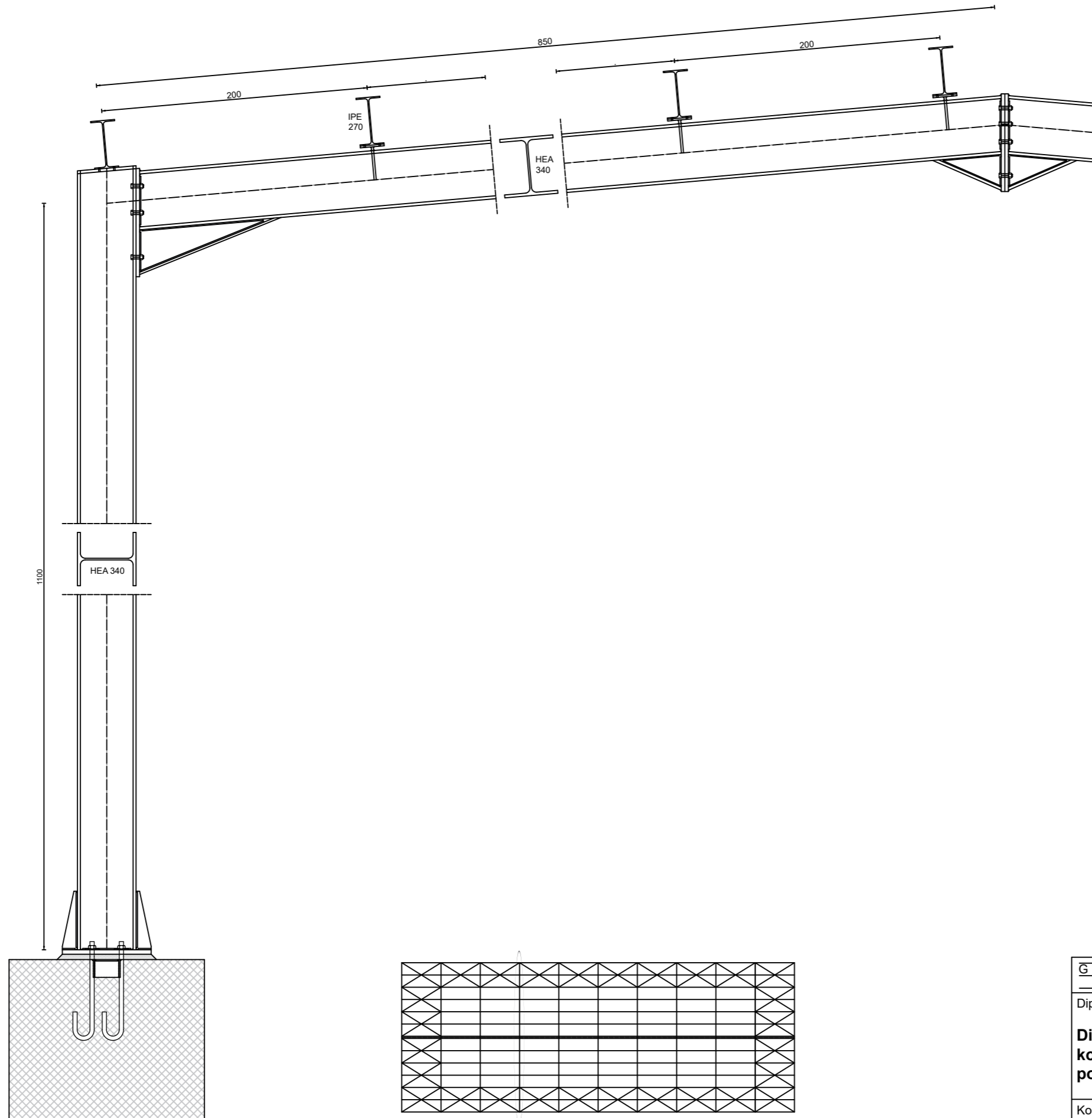

 GRAĐEVINSKI FAKULTET SVEUČILIŠTA U RIJECI			
Diplomski rad:		Sadržaj nacрта:	
Dimenzioniranje čelične konstrukcije proizvodnog pogona		Portalni okvir	
Kolegij:		Kolegij:	
Marin Ivković		Čelične konstrukcije	
Mentor:	Izv.prof.dr.sc. Mladen Bulić dipl.ing.građ.	Datum:	11.09.2023.
		Mjerilo:	1:25
		List:	7