

Determination of Seismic Load for Buildings using Different Response Spectra and Application on Different Methods of Analysis

Čaušević, Mehmed; Mitrović, Saša; Bulić, Mladen

Source / Izvornik: **Cogent Engineering, 2023, 10**

Journal article, Published version

Rad u časopisu, Objavljena verzija rada (izdavačev PDF)

<https://doi.org/10.1080/23311916.2023.2220494>

Permanent link / Trajna poveznica: <https://um.nsk.hr/um:nbn:hr:157:387459>

Rights / Prava: [Attribution 4.0 International](#) / [Imenovanje 4.0 međunarodna](#)

Download date / Datum preuzimanja: **2024-11-27**



Repository / Repozitorij:

[Repository of the University of Rijeka, Faculty of Civil Engineering - FCERI Repository](#)



Determination of Seismic Load for Buildings using Different Response Spectra and Application on Different Methods of Analysis

Mehmed Čaušević, Saša Mitrović & Mladen Bulić

To cite this article: Mehmed Čaušević, Saša Mitrović & Mladen Bulić (2023) Determination of Seismic Load for Buildings using Different Response Spectra and Application on Different Methods of Analysis, Cogent Engineering, 10:1, 2220494, DOI: [10.1080/23311916.2023.2220494](https://doi.org/10.1080/23311916.2023.2220494)

To link to this article: <https://doi.org/10.1080/23311916.2023.2220494>



© 2023 The Author(s). Published by Informa UK Limited, trading as Taylor & Francis Group.



Published online: 06 Jun 2023.



Submit your article to this journal [↗](#)



Article views: 339



View related articles [↗](#)



View Crossmark data [↗](#)



Received: 25 February 2023
Accepted: 29 May 2023

*Corresponding author: Mehmed Čaušević, Faculty of Civil Engineering, University of Rijeka, R. Matejčić 3, HR-51000 Rijeka, Croatia
E-mail: mcausevic@gradri.uniri.hr

Reviewing editor:
Sanjay Kumar Shukla, School of Engineering, Edith Cowan University, Joondalup, WA 6027, Australia

Additional information is available at the end of the article

CIVIL ENGINEERING | RESEARCH ARTICLE

Determination of Seismic Load for Buildings using Different Response Spectra and Application on Different Methods of Analysis

Mehmed Čaušević^{1*}, Saša Mitrović² and Mladen Bulić¹

Abstract: The response spectra defined in the appropriate Euro standards from the first and second generation (EN 1998–1 and EN 1998-1-1), which determine the seismic load for common buildings, are critically presented first. To avoid a reduction in earthquake loading on structures using response spectra, only a few points of the response spectra in the second generation of EN 1998-1-1 are determined by applying the probabilistic concept of seismic hazard assessment. The comparison of current response spectra in EN 1998–1 is made with the uniform hazard spectra (UHS). The comment and application of the second generation of EN 1998-1-1 is a novelty that is introduced in this paper. On the basis of response spectra presented here according to EN 1998–1 and EN 1998-1-1 and other spectra obtained from real and artificial records, comparative different methods of analysis on one regular simple eight-story reinforced concrete frame structure are illustrated to find out how the kind of spectra and used methods of analysis influence the story displacements and story drifts of one simple regular structure. So, at the same time, the reader will be informed not only about novelties in the second generation of EN 1998-1-1 as far as response spectra are concerned but also understand the implication of various response spectra on the methods of analysis of building structures.

Subjects: Earth Sciences; Structural Engineering; Mechanics; Engineering Education

Keywords: Euro standards; buildings; earthquake loading; response spectra; uniform hazard spectra; real and artificial earthquake records, attenuation prediction

1. Introduction

Designers should have prior knowledge and should decide when to use a certain type of response spectrum accordingly to determine the method of calculation of the specific structure of the building. In this paper, the designer options for the type of response spectrum determination and the calculation method of the structure for a certain building type are discussed.

Although the response spectra are scientifically dealt with and defined in the Euro standard EN 1998 by seismologists, however, in this paper, the response spectra are discussed from the aspect of a structural civil engineer.

All types of response spectra, which are nowadays in use are presented in this paper, from those defined in the appropriate Euro standards of the first and second generations, which determine the seismic load for conventional buildings, to the response spectra generated from real or artificial records of time-history acceleration, which are used to calculate seismic loads for significant buildings, which must be operational immediately after an earthquake. Additionally, uniform hazard spectra (UHS) are presented and discussed here despite not yet being prescribed in EU standards.

First, this paper briefly and critically presents the response spectra in the current standard EN 1998-1 as well as in the second generation of the same standard, which will be in power soon. The second generation of this standard EN 1998-1-1 arose given all the shortcomings of the response spectra in the current standard EN 1998-1.

Response spectra that are currently in use have only one point determined according to the probabilistic concept of seismic hazard assessment (that is, the peak ground acceleration PGA for $T = 0$), while the response spectra of the second generation of the same standard have several such points and will be presented in this paper.

Response spectra better reflect the seismic action on a building if as many points of the spectrum are determined on the probabilistic concept of seismic hazard assessment. In the uniform hazard spectrum (UHS), all points of the spectrum are determined according to the probabilistic concept of seismic hazard assessment. Thus, UHS is presented and compared in this paper to response spectra of the first generation of Euro standard EN 1998-1.

Structural Euro standards of the first generation have been in use for almost twenty years, during which period scientific research has been conducted worldwide in the field of earthquake engineering. Thus, based on the results of worldwide research, it is logical that all existing structural Euro standards should be updated while some should be completely new.

The novelties and the primary objective of the work presented in this paper are:

- Presentation of the response spectra of the second generation defined in the final draft of EN 1998-1-1, which will be in power soon. Designers should be gradually informed about changes in current standard EN 1998-1: 2004 promptly;
- Discussion on the shape of response spectra according to the second generation of EN 1998-1-1 with an explanation of the reasons for such a shape. The comment and application of the second generation of EN 1998-1-1 is a novelty that is presented in this paper;
- The comparison of results obtained in calculations applied on one simple regular structure, using different response spectra and different methods of analysis, according to Table 3 in Chapter 2.2 of this paper.

2. Response spectra of the first- and second-generation Euro standards for structures in seismic areas, their disadvantages and advantages

2.1. Response spectra of current Euro standard EN 1998-1

The Euro standard for seismic areas (Eurocode, 2004, 2011) in its first part from the beginning of its application has already imposed some dilemmas regarding the response spectra prescribed in the National Annex of each European country. Each European country within the EU passed a long debate about which parts of the country apply Type 2 response spectra based on surface magnitudes less than or equal to 5.5 and which parts apply Type 1 response spectra for surface magnitudes greater than 5.5. A similar procedure has been made in Slovenia, Italy, Austria, etc. In Figure 1 shows the response spectra, which are finally accepted for use in the EU. The

Figure 1. Elastic response spectra $S_e(t)$: (a) Type 1 ($M_s > 5,5$) and (b) Type 2 ($M_s \leq 5,5$) for all soil classes and viscous damping ratio 5% in the current Euro standard (Eurocode, 2004).

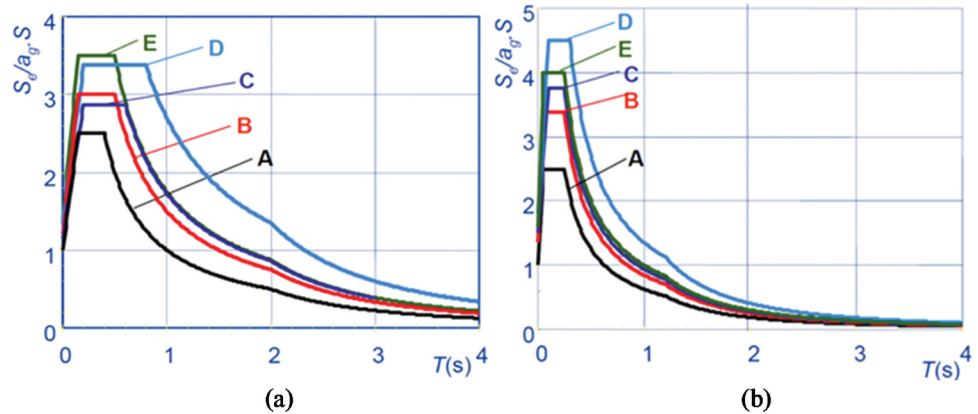

seismologists in Croatia and elsewhere in the EU did not evaluate at all the introduction of surface magnitude M_s as a measure for selecting the spectrum type (Dasović et al., 2015; Herak & Prevlnik, 2017).

The following observations were made during the application of these response spectra in the last almost 20 years:

- The design acceleration can be three times *too little/too much* for long periods if the proper type of response spectrum is not selected, Figure 2.
- The elastic response spectra of Type 1 and Type 2 have introduced confusion in the professional and scientific community. Namely, seismologists believe that the Type 1 and Type 2 response spectra are completely inappropriate (Dasović et al., 2015; Herak & Prevlnik, 2017).
- Surface magnitude M_s is inappropriate as a measure of earthquake magnitude. In the proposal of the second generation of the same Euro standard (2022) the moment magnitude M_w is introduced instead of the surface magnitude M_s .

Figure 2. Response spectrum ratios Type 1/Type 2 for different soil classes A, B, C, D, E (5% viscous damping ratio).

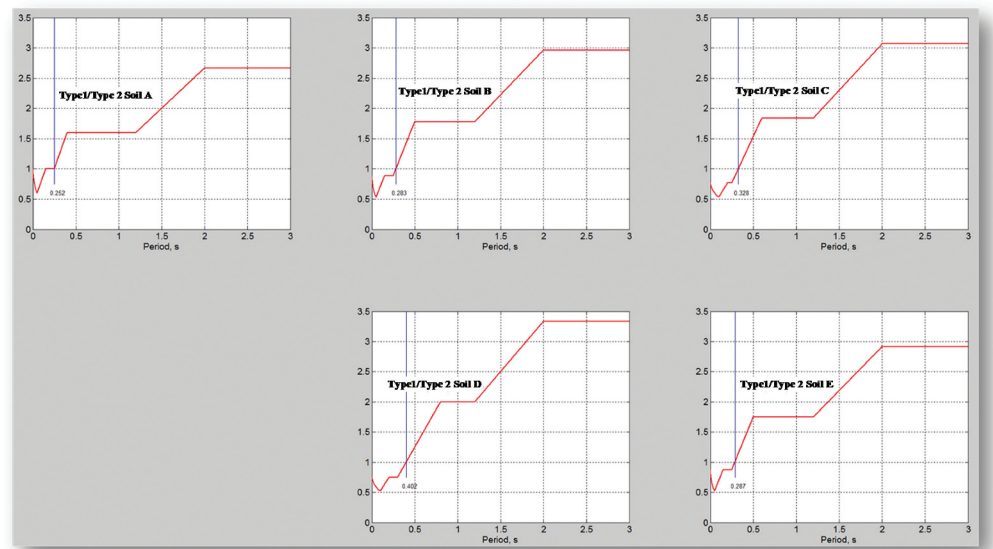

- There is only one point of these response spectra that is determined according to the probabilistic concept of seismic hazard assessment (PGA for $T=0$, Figure 1), and all other points of these spectra are determined deterministically.
- There are other uncertainties that arise during the application of these response spectra, which will be discussed in this paper.

2.2. Response spectra according to the proposal of the second generation of the Euro standard for seismic areas EN 1998-1-1

Considering all the shortcomings of the current standard EN 1998-1: 2004 as far as response spectra are concerned, the second generation of the European standard for seismic areas is proposed (2022). This proposal is scheduled to be in full power soon, probably in 2024. It is made by subcommittee SC8 of the Technical Committee TC 250 of the EU Commission. The existing standard EN 1998-1: 2004 is divided in the proposal of the second generation of this standard into two parts: EN 1998-1-1 (final draft, which deals with basic concepts and seismic actions) and EN 1998-1-2 for buildings. Based on the proposal given in EN1998-1-1, which defines seismic loads on structures and will be commented on in this paper, all other parts of Eurocode 8 (for buildings, bridges, retrofit of buildings, silos, tanks, foundations and supporting structures and high slender structures supported by cables and high chimneys) will be examined. Notably, in this proposed second-generation standard, the elastic and reduced response spectra are defined in a completely different way in comparison to how the spectra were defined in the first generation of this standard. This result arises from the application of scientific research in the European Union and the world in the past 20 years in the field of earthquake engineering.

In 2024, the complete second generation of Eurocode 8 is expected to be technically ready, followed by its translation into the official languages of the EU (Labbé & Paolucci, 2022).

For all those involved in earthquake engineering, a significant date is an imminent entry into power of the new Euro standards for earthquake-prone areas, which will contain radical changes to the standards currently in power. Therefore, EU designers should be gradually informed about changes in current standard EN 1998-1: 2004 in a timely manner.

The fact that no amendments were made to the existing standard EN 1998-1: 2004, but rather completely new standards EN 1998-1-1 and EN 1998-1-2 are created, indicates radical changes to the existing standard.

The most significant changes are listed below (Labbé & Paolucci, 2022; Čaušević et al., 2020):

- Maps showing seismic hazard values should be prescribed by the National Committee of each EU country. The European Seismic Hazard Maps are derived from deliverable ESHM20 of the SERA research project (Seismology and Earthquake Engineering Research Infrastructure Alliance for Europe), which received funding from the EU Horizon 2020 research and innovation program in order to provide updated information on the seismic hazard in Europe (Danciu et al., 2021), Figure 3.
- Earthquake return periods are defined by two parameters: selected limit state (LS) and selected consequence class (CC) for buildings (Table 1).
- Nine earthquake return periods are introduced (so far there have been only two in the current standard EN 1998-1), which means that as a rule, 18 maps should be made (9 return periods and each with two spectral ordinates S_{α} and S_{β} , which will be introduced and explained later in this paper). At least two maps should be made because multiplication factors can be used

Figure 3. Informative small-scale European Hazard Map representation of Salpha for rock sites, based on ESHM20 (explanation of Salpha will be presented below).

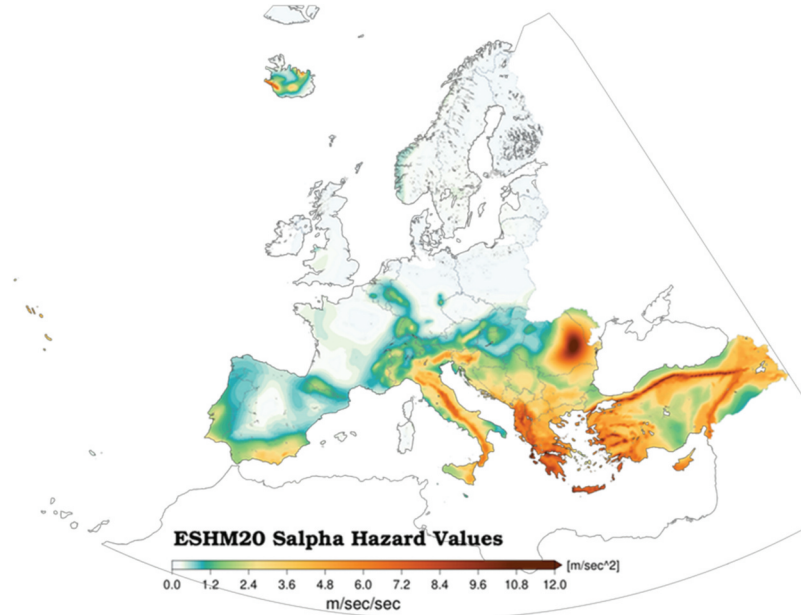

Table 1. Return period of seismic action in years

Limit state (LS)	Consequence class CC			
	CC1	CC2	CC3-a	CC3-b
NC	800	1600	2500	5000
SD	250	475	800	1600
DL	50	60	60	100

Table 2. Multiplication factor YLS

Limit state (LS)	Consequence class CC			
	CC1	CC2	CC3-a	CC3-b
NC	1,2	1,5	1,8	2,2
SD	0,8	1	1,2	1,5
DL	0,4	0,5	0,5	0,6

(Table 2). The number of maps will be decided in each EU country and prescribed in the National Annex of each EU country.

- Four limit states are introduced in the second generation of Eurocode 8-1-1 and presented in Tables 1 and 2: near collapse limit state (NC), significant damage limit state (SD), damage limitation limit state (DL) and fully operational limit state (OP). CC denotes the Consequence Class. These four limit states should not be exceeded under prescribed seismic actions.
- The response spectra in the second generation EN 1998-1-1 are fixed with several points determined according to the probabilistic concept of seismic hazard assessment (other points of the spectrum are defined deterministically), and these points are shown in Figure 4: spectral values “on the plateau” and spectral values for $T = 1s$ and $T = T_A$. In the existing spectrum EN 1998-1: 2004, only one point was probabilistically defined (PGA, $T = 0$). This means that the

scaling of the seismic input is no longer PGA (peak ground acceleration), as in EN 1998-1: 2004, but instead, two spectral ordinates, S_α and S_β , are introduced.

- The previous elastic response spectra of Type 1 and Type 2 are abolished. A new moment magnitude M_w is introduced instead of the surface magnitude M_s . The moment magnitude M_w relates the magnitude of the earthquake and the energy released, considering the slip in the fault as well as the value of the surface on which the slip occurs (for example, $M_w = 8.8$ for a catastrophic earthquake that hit Chile on 27 March 2010).
- Instead of the two limit states that have been described so far (NCR and DLR), four limit states are introduced as presented above.
- The concept of the behavior factor is applied in all modern standards in the world (in some, different designations are used). In the second generation of EU standard EN 1998-1:2004, the concept of the behavior factors q has been retained, but q factors are defined differently from the way how it is defined in the current EN standard (Eurocode, 2004) and consists of three components (Labbé & Paolucci, 2022; Čaušević et al., 2020). The behavior factors will be given in EN 1998-1:2004 for buildings.

The reference seismic hazard in EN 1998-1-1 is described with the following two parameters (Figure 4):

- S_α is the reference maximum spectral acceleration corresponding to the acceleration “on the plateau” of the elastic response spectrum (Figure 4) with a 5% viscous damping ratio for site category A and the return period $T_{ref} = T_{SD,2}$.

Figure 4. Elastic response spectra for site category a and two different pairs (S_α S_β) for two seismic levels: ($S_\alpha = 3 \text{ m/s}^2$) in blue and ($S_\alpha = 7.5 \text{ m/s}^2$) in red on the horizontal logarithmic scale (Labbé & Paolucci, 2022; Čaušević et al., 2020).

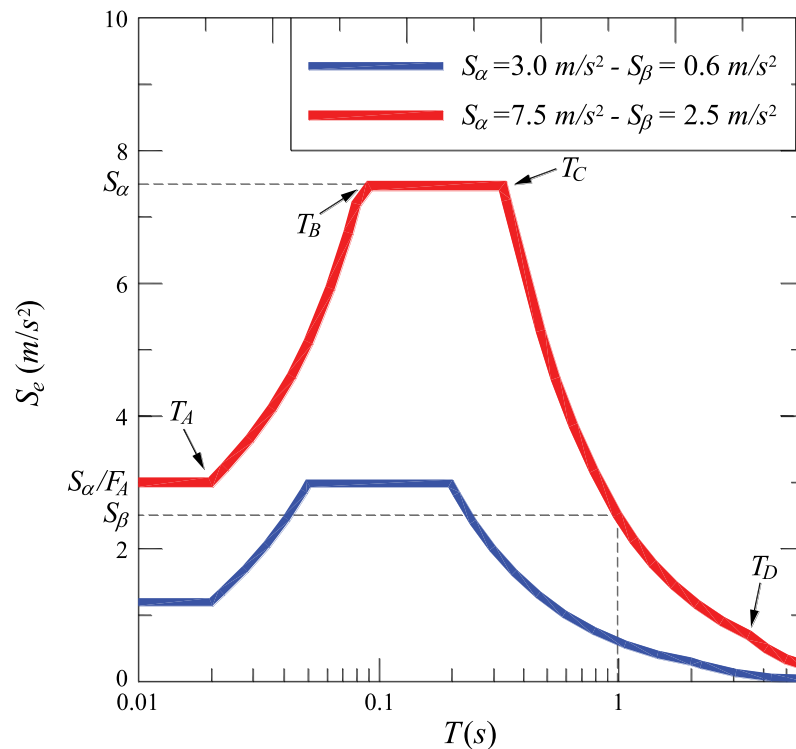

- $S_{\beta,ref}$ is the reference spectral acceleration for the vibration period $T_{\beta} = 1s$, with a 5% viscous damping ratio, for site category A and the return period $T_{ref} = T_{SD,2}$.

These parameters $S_{\alpha,ref}$ and $S_{\beta,ref}$ will be determined by seismologists, who will make national hazard maps for each earthquake return period presented in Table 1.

The term *design spectra* $S_d(T)$ from the existing standard EN 1998-1: 2004 has been rejected. Instead, in the second generation of this standard, the term *reduced spectrum* $S_r(T)$ is introduced. The reduced spectra are obtained from the elastic response spectrum in Figure 4 according to a defined procedure.

Before the second generation of EN 1998-1-1 and EN 1998-1-2 enters into power, a comparative study of the values of seismic forces should be performed using the lateral static action obtained according to the currently valid response spectra and the proposal of new spectra of the second generation. It is questionable whether a reinforced concrete structure will have more reinforcement according to the spectra of the second generation in relation to the spectra valid today. At the moment, this analysis is not possible because the behavior factors q are not yet finally defined in the second generation EN 1998-1-2 for buildings.

The response spectra presented here are the basic data in the methods of analysis of structures according to EU standards. These analyses should be performed by the methods described in Table 3.

2.3. Response spectra obtained from records of real and artificial time-history accelerations

For significant buildings that must be operational immediately after a strong-intensity earthquake, the application of the response spectrum from EU standards is not sufficient. In such cases, in the

Table 3. Methods of seismic analysis and appropriate seismic loading on structures (response spectra) for different types of buildings

Method of analysis of structure	Statics	Dynamics
Linear force-based approach	Lateral forces method. Application for common buildings - no influence of higher modes and torsion effect. Use of the response spectrum defined in the Euro standard.	Modal analysis for both uncracked sections and cracked sections* (according to EN 1998-1). Application for common buildings with or without the influence of higher modes and torsion effect (Fajfar et al., 2005; Kreslin & Fajfar, 2011). Use of the response spectrum defined in the Euro standard.
Nonlinear displacement-based approach	Pushover nonlinear static procedure based on the N2 method (Fajfar, 2000) (performance-based seismic design). Application for all buildings. Use of the response spectrum defined in the Euro standard. The influence of higher modes and torsion effect is included by means of the correction factors (Fajfar et al., 2005; Kreslin & Fajfar, 2011).	Nonlinear dynamic analysis using real or artificial time-history accelerations. Application for buildings that must be operational immediately after an earthquake.

*Unless a more accurate analysis of the cracked elements is performed, the elastic flexural and shear stiffness properties of concrete (and masonry) cracked elements may be taken to be equal to one-half of the corresponding stiffness of the uncracked elements.

Figure 5. Record of time-history acceleration for the Ston earthquake (Croatia) and the corresponding response spectra (Herak & Prevolinik, 2017).

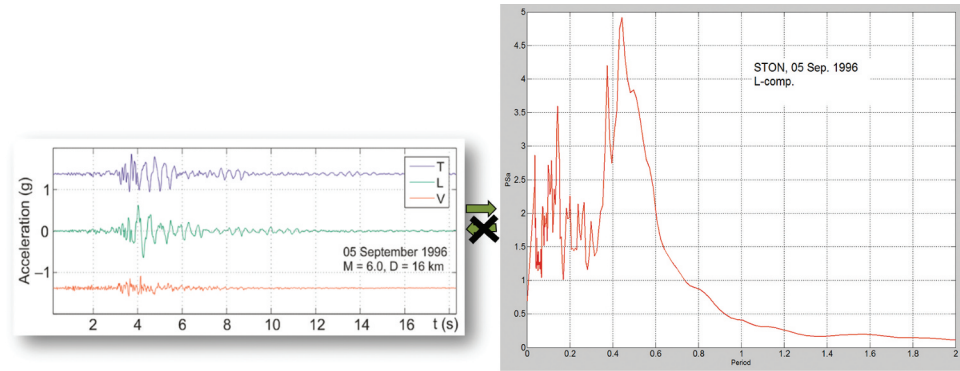

process of structural design, the relevant earthquakes for the location of the building should be first determined by a special study, and the appropriate response spectra should be determined from the acceleration record for these relevant earthquakes. The corresponding response spectra for these relevant earthquakes represent the seismic load on the structure. Additionally, as a seismic load for buildings, the record of time-history acceleration of real or artificial earthquakes can be used directly (Gelfi, 2007; Naumoski et al., 1988; Naumoski, 1988) to perform a nonlinear dynamic analysis of the structure (Causevic & Mitrovic, 2011). An example of a nonlinear dynamic analysis will be presented in part 4 of this paper. Figure 5 presents an example of the record of time-history acceleration for the Ston earthquake (Croatia, magnitude 6; 5 September 1996) and the corresponding response spectrum for that earthquake (Herak & Prevolinik, 2017), which is obtained according to the procedure described in (Chopra, 2001; Čaušević, 2014).

Based on the shape and peak acceleration values of this response spectrum, it can be concluded that the spectra from Euro standards do not represent the spectrum of any earthquake in the past but are the result of compromise and approximately simulate real response spectra, such as the response spectra in Figure 4.

Figure 6 presents the response spectra obtained from the records of seven well-known real earthquakes in the world (at least seven are prescribed in the Euro standard EN 1998-1): Imperial Valley (USA, California, May 18th, 1940, El Centro), Ulcinj (Montenegro, April 15th, 1979, Hotel Albatros), Mexico City (Mexico, September 19, 1985, La Villita, Guerrero Attay), Kocaeli (Turkey, August 17th, 1999, Sakaria), San Fernando (USA, California, February 9th, 1971, 3938 Lankershim Blvd., L.A.), Honshu (Kobe, Japan, August 2nd, 1971, Kushiro Central Wharf) and Kern County (USA,

Figure 6. Response spectrum of the selected real earthquakes together with elastic response spectra from the EN 1998–1 (black line) and its 90% value (dotted line) for soil class B and PGA=0.3 g and 5% viscous damping ratio.

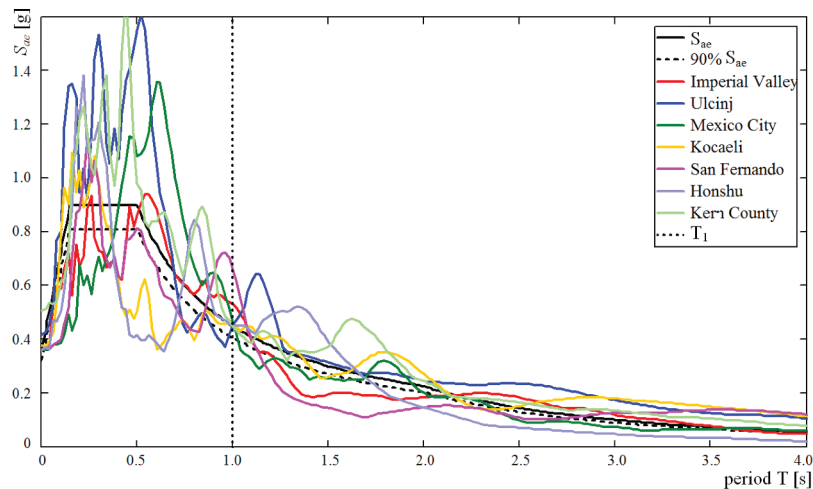

California, July 21st, 1951, Taft Lincoln School Tunnel). Figure 6 also presents the elastic response spectrum prescribed in the current Euro standard EN 1998–1 for soil class B and PGA = 0.3 g, as well as 90% of the value of this spectrum. The values of the response spectra obtained as an average of all response spectra must not be less than 90% of the spectrum values from the Euro standard.

The maximum response of an SDOF system subjected to a specific ground motion for all seven real earthquakes is obtained using the procedure given in (Chopra, 2001; Čaušević, 2014) and is presented in Figure 6.

Artificial time-history acceleration records are used to obtain the average value of the response of the structure. Usually, seven such artificial records are used (at least seven are prescribed in the EN 1998–1), which are generated by the program SIMQKE_GR (SIMulation of earthQuaKE GRound motions—Massachusetts Institute of Technology) (Gelfi, 2007).

Figure 7 presents the elastic response spectrum prescribed in the current Euro standard obtained for 5% damping, soil class B and PGA = 0.3 g (red line). It also presents the digitized artificial record that was applied to obtain the response spectra (black line). The duration of an artificial earthquake is 20 s. In Figure 7, it can be noticed that there is no value of period T for which the obtained elastic acceleration for the artificial time history presented in Figure 8 is less than 90% (blue line) of the acceleration defined in the Euro standard (red line).

3. Uniform hazard spectra (UHS)

A few points of the response spectrum in Figure 3 are determined by applying the probabilistic concept of seismic hazard assessment, and all other points are defined deterministically. However, there are already all the preconditions for determining all points of the spectrum by applying the probabilistic concept of seismic hazard assessment for the entire territory of EU countries prone to earthquakes, especially in the Mediterranean area. Such spectra are the uniform hazard spectra

Figure 7. Response spectra in the Euro standard with a 5% viscous damping ratio and soil class B and PGA = 0.3 g (in red), its 90% value (in blue) and the response spectrum for the artificial time-history record (in black) presented in F8.

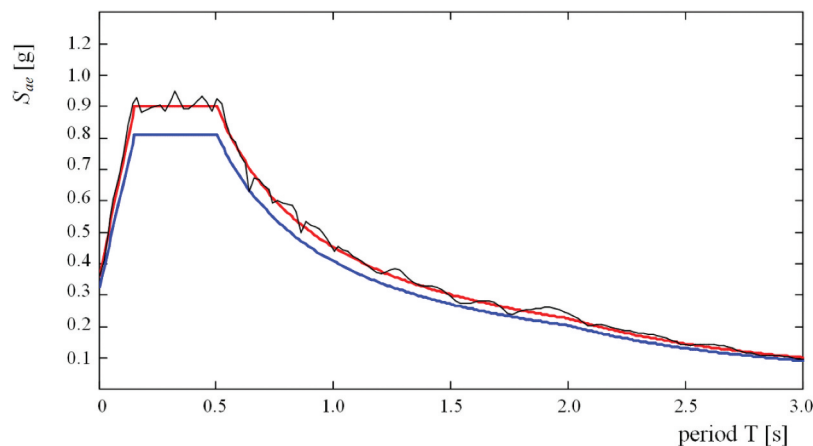

Figure 8. Digitized artificial record of time-history acceleration for which the response spectra were obtained and presented in F7.

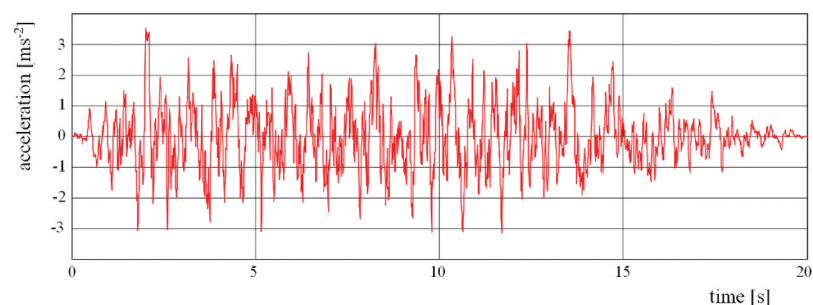
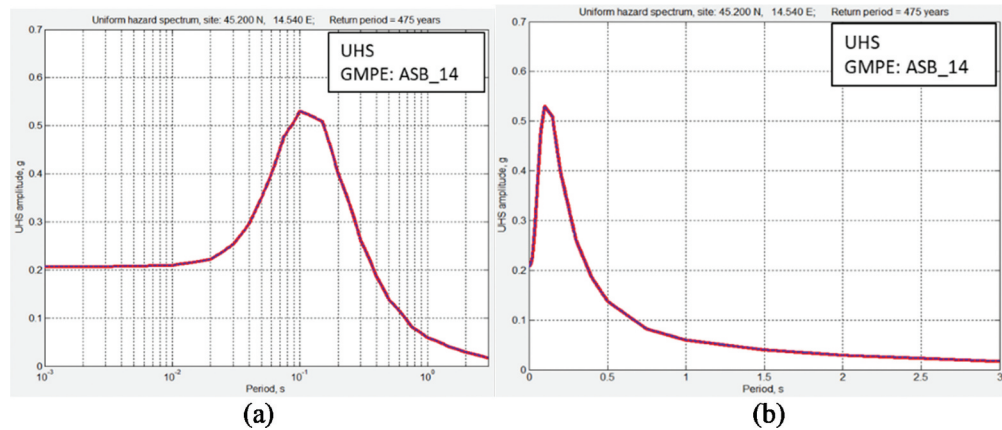

Figure 9. Uniform hazard spectra obtained by the attenuation relation ASB_14 (Akkar et al., 2014) on a horizontal logarithmic scale (a) and the same spectrum shown on a decimal scale (b).



(UHS), all ordinates of which are calculated in the same way as the reference peak ground acceleration (PGA) a_g , using appropriate modern attenuation relations. Uniform hazard spectra are the result of consistent application of probabilistic principles and were defined as early as 1977 (Anderson & Trifunac, 1977) and are currently in use in some countries (USA and Canada). The shape of the UHS spectrum depends not only on the location parameters but also on other parameters, which means that sites with the same a_g (PGA) and the same soil type can have different UHS. UHS largely depends on attenuation prediction relations (GMPE), and an up-to-date one, i.e., ASB_14, is defined in (Akkar et al., 2014), which is mostly used in Europe. The coefficients of all up-to-date attenuation relations were derived for periods from 0.0 (PGA) to periods (3–4 s) relevant to the application (Figure 9).

An example of a uniform hazard spectrum is presented in Figure 9 on both a horizontal logarithmic scale and a horizontal decimal scale. The advantage of using the horizontal logarithmic scale is observed. The uniform hazard spectrum is given in Figure 9(b) on a horizontal decimal scale so that it can be compared with the spectra from the Euro standard presented in Figure 1.

Figure 10. Comparison of uniform hazard spectra and Type 1 and Type 2 elastic response spectra from the current Euro standard for the city of Zagreb, Croatia.

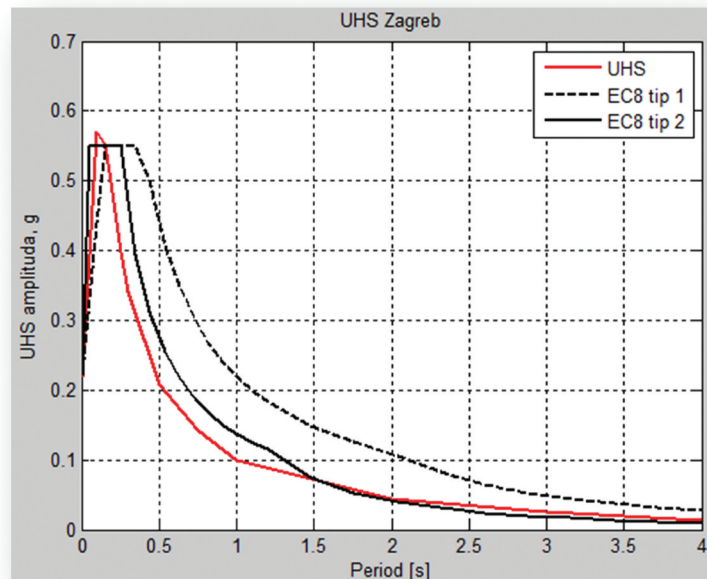
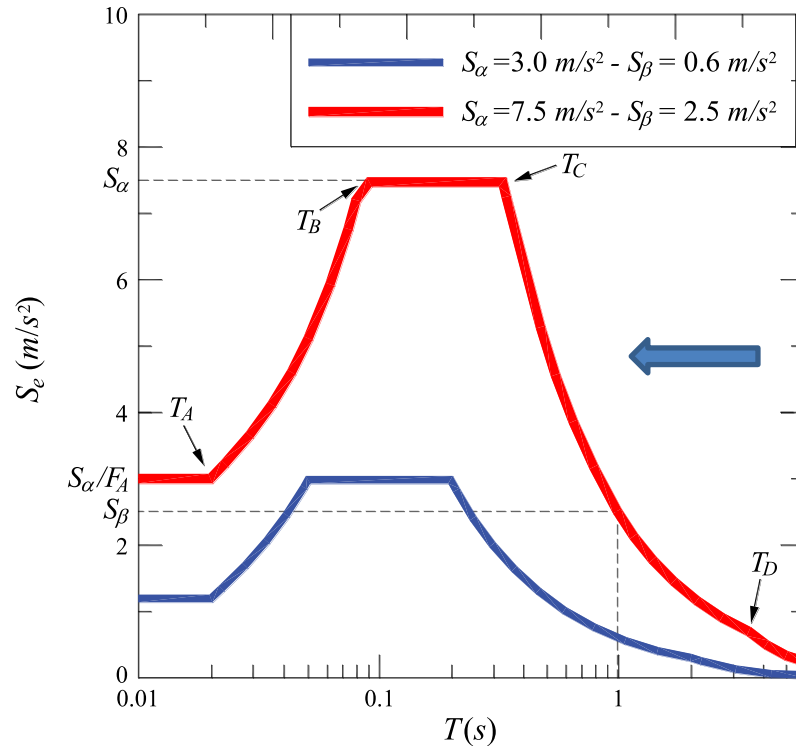

Figure 11. Elastic response spectra according to second-generation EN 1998-1-1 with the range of periods $0.5s \leq T \leq 2s$ where seismic forces are about three times greater compared to seismic loading on buildings obtained using UHS, as presented in F10.



This comparison is presented in Figure 10 for the city of Zagreb (Dasović et al., 2015; Herak & Prevolnik, 2017).

Research in Croatia (Dasović et al., 2015; Majstorović et al., 2017) shows that the attenuation of high-frequency seismic waves in the Dinarides region is pronounced, which indicates a very heterogeneous lithosphere, especially the crust. Attenuation is somewhat more pronounced in the southern part of the Dinarides than in their northern and central parts. The overall attenuation for Croatia is obtained based on the attenuations of the primary P and secondary S waves. Figure 10 shows the Type 1 and Type 2 elastic response spectra prescribed in the current Euro standard and the uniform hazard spectra for the city of Zagreb, Croatia. The UHS for Zagreb are much closer to Type 2 spectra.

Having in mind that the uniform hazard spectra are much closer to Type 2 spectra, the CEN-SC8 subcommittee (2022; Labbé & Paolucci, 2022) proposed the shape of spectra in EN 1998 Part 1-1 as presented in Figure 11 which differs from the UHS in the range of periods $0.5s \leq T \leq 2s$. Seismic loading on buildings obtained according to spectra in Figure 10 for periods $0.5s \leq T \leq 2s$ is about three times greater compared to seismic loading on buildings obtained using ultimate hazard spectra.

4. Case study: Comparison of results using different response spectra and different methods of analysis

A comparison of the results of the calculation will be presented in a simple example. The application of linear force-based analysis, modal analysis, nonlinear static and dynamic procedures (presented in Table 3) will be illustrated here using a regular (EN 1998-1) eight-story reinforced concrete frame building. The first two stories are 5.00 m high, and the other story is 3.10 m high, Figure 12.

The structure in Figure 12 was designed according to EN 1998-1: 2004 with the following parameters: ground type B, importance class II ($\gamma_I = 1$), Type 1 elastic response spectra (the expected surface-wave magnitude M_s is larger than 5.5) and viscous damping ratio $\xi = 5\%$. The

Figure 12. Part of a shopping complex with an underground garage, Rijeka, Croatia - segments separated by seismic dilatations (a); plan of one segment of the structure (b); cross-section of one segment (c).

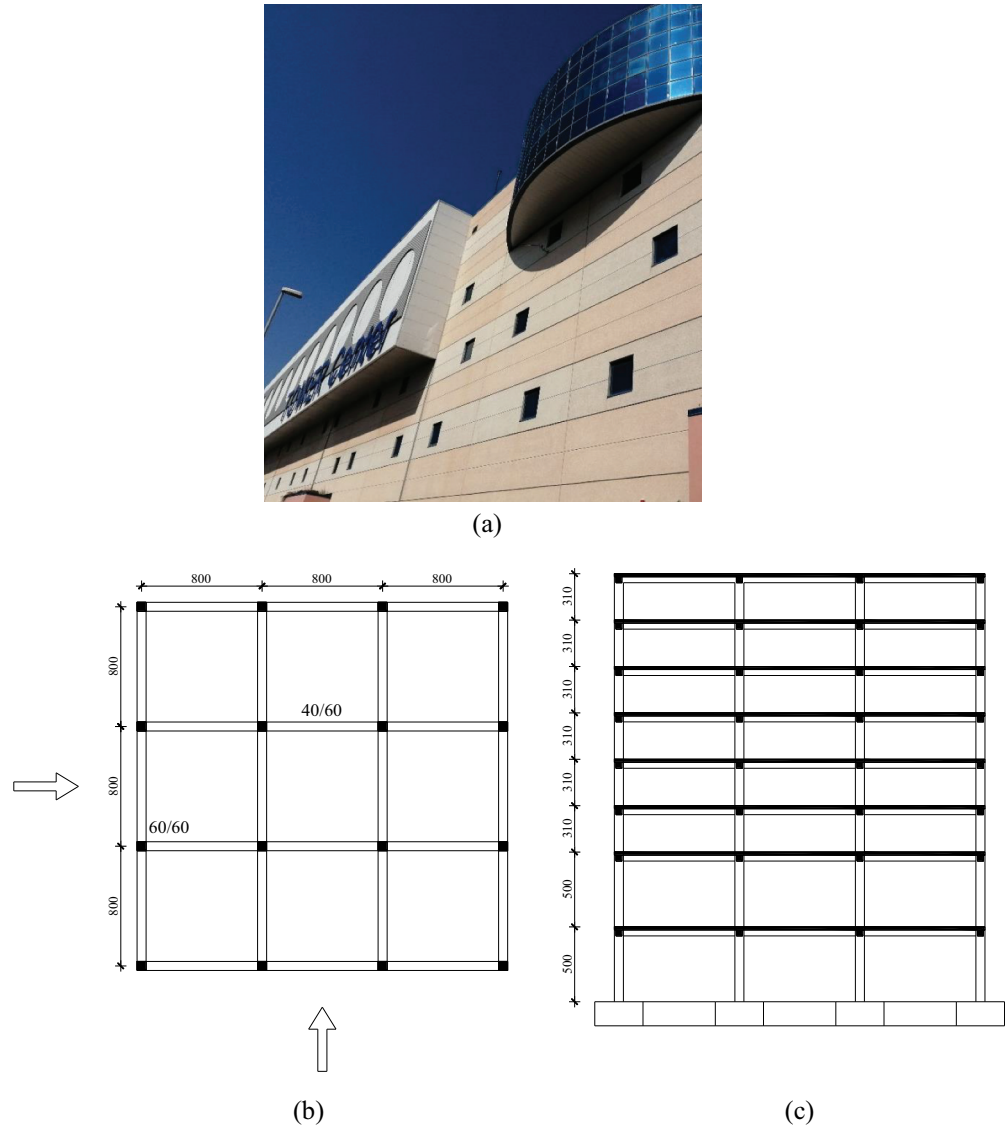
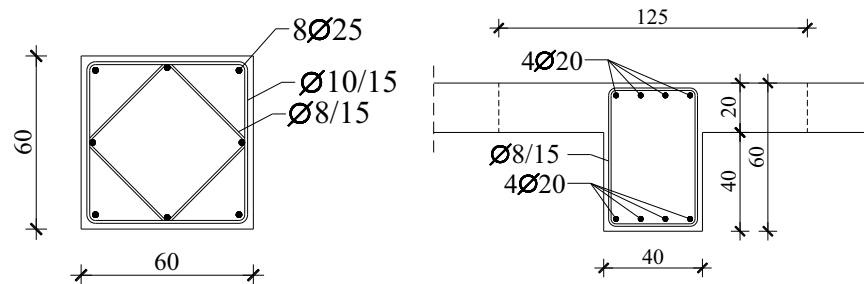

Figure 13. Cross-sections of columns and beams with steel reinforcement.



analysis was performed for the reference peak ground acceleration $a_{gr} = 0.3g$. A behaviour factor $q = 5.85$ was considered for the DCH (ductility class high) structures.

In linear methods, the reinforcement is obtained as the ultimate result (Figure 13). All the columns have dimensions of 60 cm x 60 cm with steel reinforcement equal for all cross sections. The beams have dimensions of 40 cm x 60 cm, and the steel reinforcement is equal for all cross

Figure 14. (A) 3D presentation of the regular structure in F12; (b) its plane frame in fundamental mode ($T_1 = 1s$).

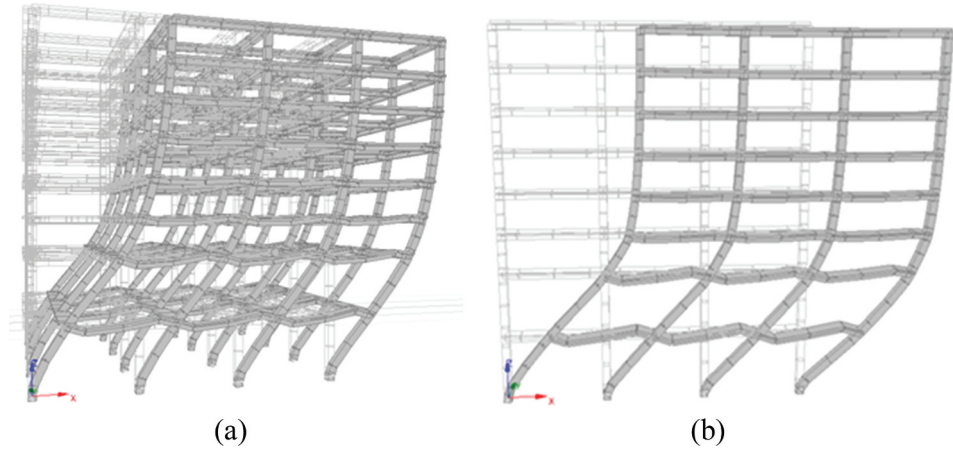

sections (Figure 13). The plate is 20 cm thick. The concrete is C25/30 class, and the steel reinforcement is B500. The story frame mass for 3.10 m high stories is 66.96 t, and the story mass for 5.00 m high stories is 73.80 t, which results in a total mass of 549.36 t.

Since the structure meets the regularity requirements by its plan and by its height, the current analysis was performed on one plane frame, Figure 14. Due to symmetry, only one direction of seismic action was analyzed, and the fundamental period $T_1 = 1s$ for the plane frame was obtained.

The elastic acceleration response spectra and the corresponding design spectra (EN 1998-1) are presented for this building in Figure 15, which represents the seismic demand for linear analysis and nonlinear static procedure (Table 3). The fundamental period $T_1 = 1s$ is in the spectrum range with constant velocities ($T_C < T_1 < T_D$) (Chopra, 2001; Čaušević, 2014). The pushover nonlinear static analysis was performed using the *SeismoSignal - Seismosoft* programs (<http://www.seismosoft.com/index.htm>).

Notably, in the application of nonlinear static procedure based on the N2 method, traditional elastic response spectra are not used in the form they are given in EN1998-1 and Figures 1 and 3, but the same spectra should be presented in AD (acceleration-displacement) format (Fajfar, 2000).

Figure 15. Elastic acceleration response spectra (red) with 5% viscous damping ratio for peak ground acceleration of 0.3 g and ground type B and corresponding design spectra for behavior factor of 5.85 (blue).

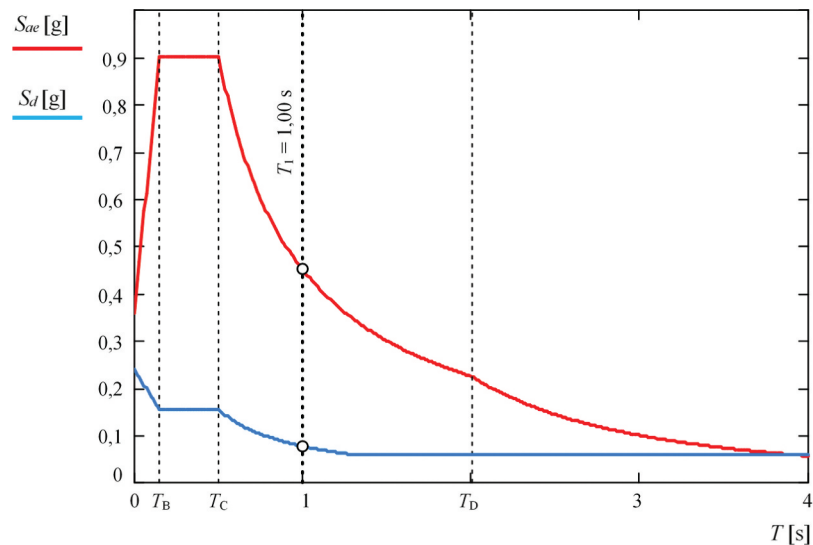
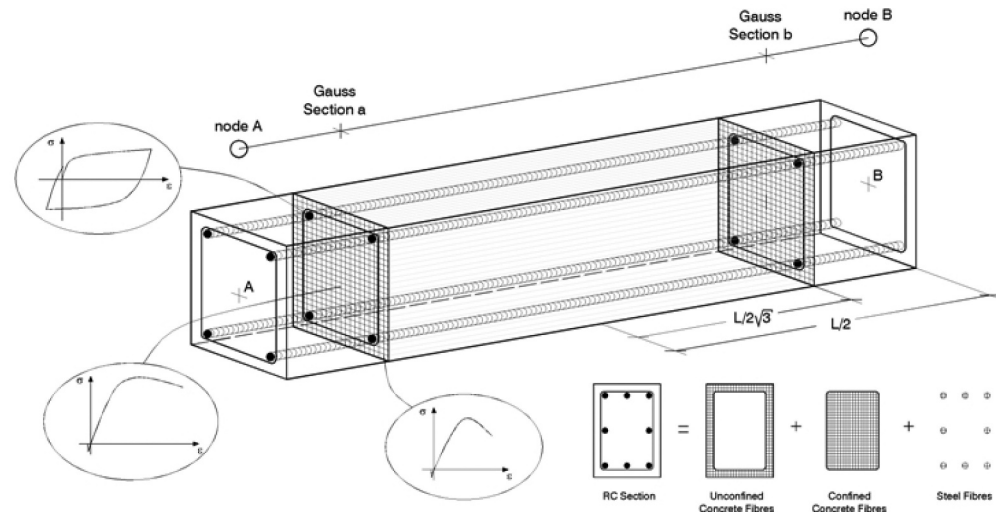

Figure 16. Fiber modelling approach: unconfined concrete fibers, confined concrete fibers and steel fibers.



To perform nonlinear analysis, cross sections and the amount of reinforcement must be known, and as a result, deformations (displacements and story drift), i.e., structural damage (rotations of certain cross sections) will be obtained.

Material inelasticity and the cross-section behavior are represented through the fiber modelling approach, where each fiber is associated with a uniaxial stress–strain relationship. Each cross-section has a number of fibers (200 to 400), and for each fiber, a nonlinear ratio ϵ – σ is defined in Figure 16.

A typical reinforced concrete section consists of unconfined concrete fibers, confined concrete fibers and steel fibers (Figure 16). Nonlinear models for confined and unconfined concrete were used. A bilinear steel model with kinematic strain hardening was used. An incremental iterative algorithm with the employment of Newton-Raphson procedure was used to obtain the solution. The dynamic time-history analysis was computed by direct integration of the equations of motion with the Newmark scheme (Chopra, 2001).

Figure 17 and Figure 18 present the comparison of maximum absolute displacements and story drifts calculated by all methods presented in Table 3, i.e., equivalent static forces, modal analysis, nonlinear static method, and nonlinear dynamic method using 7 real time-history records (Figure 6) and 7 time-history artificial records (Figures 7, 8). In Figures 17 and 18, average values of the nonlinear dynamic analysis are also presented.

The results of the modal analysis are presented here by using response spectra for both uncracked sections and cracked sections in such a way that the elastic flexural and shear stiffness properties of concrete cracked elements are taken to be equal to one-half of the corresponding stiffness of the uncracked elements (a more detailed analysis is presented in (Čaušević et al., 2012)).

At the moment, an analysis of this structure using the response spectra of the second-generation standard is not possible because the behavior factor q is not yet finally defined in the proposal of the second generation of EN 2 January 1998 for buildings.

5. Comments on the obtained results and conclusions

Before the second-generation Euro standards, EN 1998-1-1 and EN 1998-1-2 enter into power, a comparative study of the values of seismic loading should be performed using the lateral static

Figure 17. Comparison of maximum absolute displacements obtained by (a) equivalent static forces of the current standard EN 1998-1 (yellow); (b) modal analysis using response spectra for uncracked sections (light green) and (c) cracked sections (green); (d) pushover procedure based on the N2 method (red); (e) an average of nonlinear dynamic analysis using 7 real time-history records (black); and (f) an average of nonlinear dynamic analysis using 7 time-history artificial records (blue).

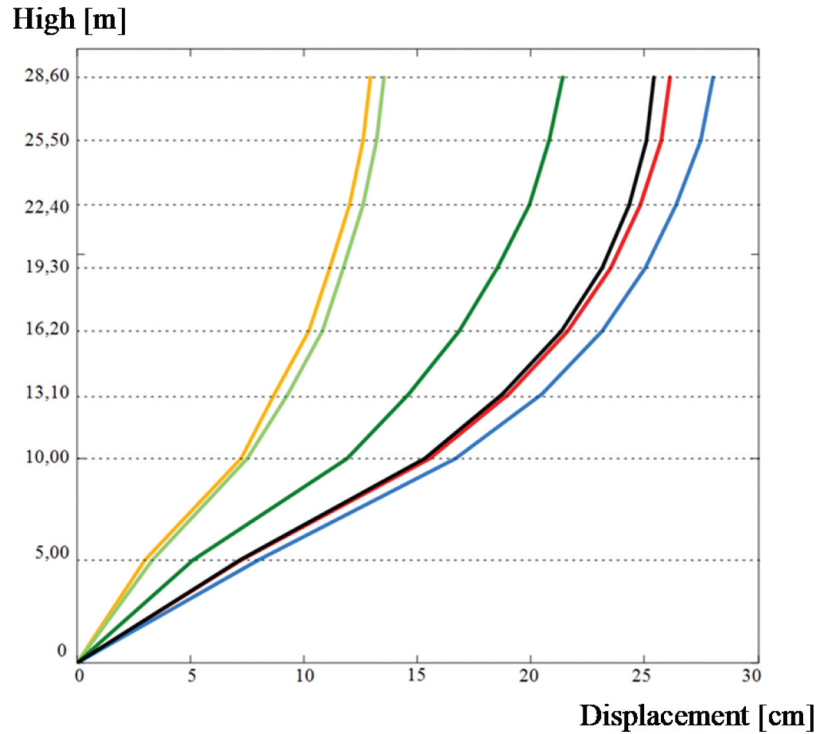
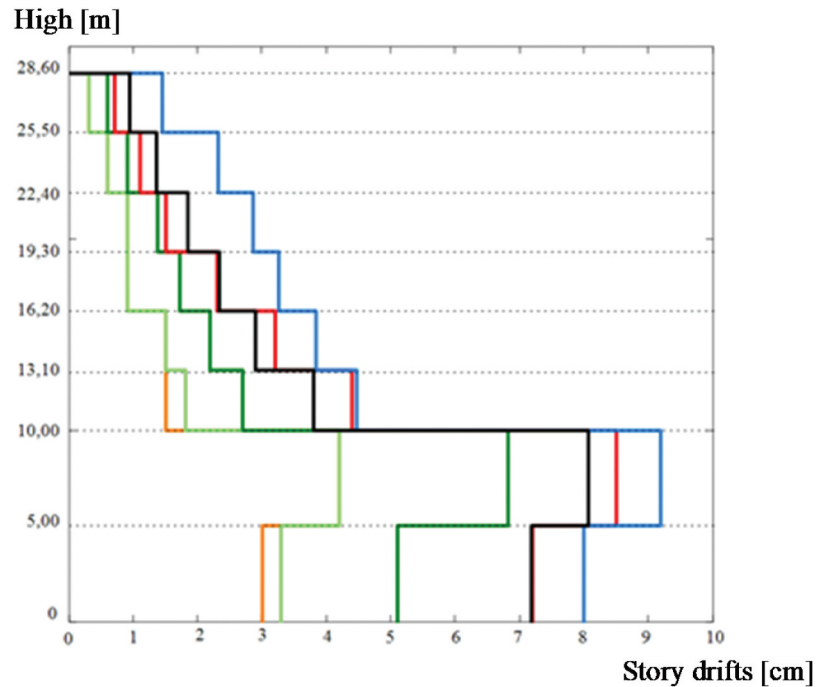

Figure 18. Comparison of maximum story drifts obtained by (a) equivalent static forces of the current standard EN 1998-1 (yellow); (b) modal analysis by using response spectra for uncracked sections (light green) and (c) cracked sections (green); (d) pushover procedure based on the N2 method (red); (e) an average of nonlinear dynamic analysis using 7 real time-history records (black); and (f) an average of nonlinear dynamic analysis using 7 time-history artificial records (blue).



forces method (Table 3) according to the current spectra and spectra in the second generation of the same standard. This means that for one common reinforced concrete structure, such as the structure in Figure 12, it is currently unknown whether it will have more or less reinforcement according to the new spectra in the second generation of Euro standard EN 1998-1-1. At the moment, this comparative analysis is not possible because the behavior factors q is not yet finally defined in the last draft of the second generation EN 1998-1-2 for buildings.

Keeping in mind the introduced innovations in the second-generation Euro standards EN 1998-1-1 and EN 1998-1-2, all software used for the design of structures will need to be supplemented and amended in the sense as set out in this paper, i.e., as prescribed by the second generation of these standards. This particular finding refers to the introduction of calculation by the nonlinear static method, which does not exist in the software that is currently used in everyday practice (Nemeček, Tower, etc.); however, in most of these programs, there is a linear method of lateral static load and modal analysis only.

Each EU country should start working on seismic hazard maps as soon as possible to have everything necessary for the new hazard maps in the National Annex for the application of the second generation Euro standard EN 1998-1-1.

In the response spectrum of the existing standard EN 1998-1: 2004, only the value of the spectrum for $T=0$ (PGA, soil class A) is determined according to the probabilistic concept of seismic hazard assessment, while in the proposal of the second-generation response spectrum presented in Figure 4, more spectral points are determined according to the probabilistic concept of seismic hazard assessment.

It is presented why in the second generation EN 1998-1-1 the CEN-SC subcommittee proposed spectra that are a compromise between the deterministically obtained response spectrum (Figure 1) and the uniform hazard spectrum, Figure 10.

Having in mind that the uniform hazard spectra are much closer to Type 2 spectra, the CEN-SC8 subcommittee proposed the shape of spectra in EN 1998-1-1 as presented in Figure 11 which differs from the UHS in the range of periods $0.5s \leq T \leq 2s$. Seismic loading on buildings obtained according to spectra in Figure 11 for periods $0.5s \leq T \leq 2s$ is about three times greater compared to seismic loading on buildings obtained using ultimate hazard spectra.

The study of the propagation and attenuation of high-frequency S-waves in the Earth's crust is of great importance for seismology and civil engineering. Good knowledge of attenuation enables a quality assessment of seismic hazards and earthquake parameters.

The obtained results in the case study presented here differ in the displacements of buildings depending on the sort of response spectra and the presented methods of calculation (Table 3).

It is once more confirmed that the application of more accurate nonlinear methods results in larger deformations of the structure. This means that the structure can deform (has reserves in the structural deformability) and at the same time remains safe from destruction.

Acknowledgments

The research presented in this paper was sponsored in part by the University of Rijeka, Croatia, as part of Research Project No. uniri-tehnic-18-127.

Author details

Mehmed Čaušević¹
E-mail: mcausevic@gradri.uniri.hr
ORCID ID: <http://orcid.org/0000-0003-0923-2345>
Saša Mitrović²

Mladen Bulić¹

¹ Faculty of Civil Engineering, University of Rijeka, Rijeka, Croatia.

² I.T.T. D.O.O, Rijeka, Croatia.

Disclosure statement

Professor emeritus Mehmed Čaušević, the corresponding author

On behalf of all authors of the manuscript
"Determination of Seismic Load for Buildings using

Different Response Spectra and Application on Different Methods of Analysis,” I declare that we have no known competing financial interests or personal relationships that could have appeared to influence the work reported in this paper.

Correction

This article has been corrected with minor changes. These changes do not impact the academic content of the article.

Citation information

Cite this article as: Determination of Seismic Load for Buildings using Different Response Spectra and Application on Different Methods of Analysis, Mehmed Čaušević, Saša Mitrović & Mladen Bulić, *Cogent Engineering* (2023), 10: 2220494.

References

- Akkar, S., Sandikkaya, M. A., & Bommer, J. J. (2014). Empirical ground-motion models for point-and extended-source crustal earthquake scenarios in Europe and the Middle East. *Bulletin of Earthquake Engineering*, 12(1), 359–387. <https://doi.org/10.1007/s10518-013-9461-4>
- Anderson, J. G., & Trifunac, M. D. 1977. Uniform risk functionals for characterization of strong earthquake ground motion. Report No. 77-02, Department of Civil Engineering, University of Southern California.
- Čaušević, M. 2014. *Dynamics of Structures – Application to Earthquake Engineering and Aerodynamics* (2nd ed.). Golden Marketing, Croatia (in Croatian).
- Čaušević, M., Bulić, M., & Lakusic, S. (2020). Proposal of response spectra in the second generation of Eurocode EN1998-1-1 for seismic areas and comparison with the existing standard EN 1998-1: 2004. *Journal of the Croatian Association of Civil Engineers*, 72(10), 895–904. <https://doi.org/10.14256/JCE.2838.2019>
- Čaušević, M., Franković, T., & Mahmutović, N. (2012). Effects of stiffness reduction on seismic capacity of buildings. *Journal of the Croatian Association of Civil Engineers*, 64(6), 463–474. <https://doi.org/10.14256/JCE.668.2011>
- Causevic, M., & Mitrovic, S. (2011). Comparison between non-linear dynamic and static seismic analysis of structures according to European and US provisions. *Bulletin of Earthquake Engineering*, 9 (2), 467–489. <https://doi.org/10.1007/s10518-010-9199-1>
- Chopra, A. K. (2001). *Dynamics of Structures – Theory and Application to Earthquake Engineering* (2nd ed.). Prentice-Hall.
- Danciu, L., et al. (2021). The 2020 update of the European Seismic hazard model: Model Overview. *EFEHR Technical Report, 1*. <https://doi.org/10.12686/a15>
- Dasović, I., Ruščić, M., Herak, D., & Herak, M. (2015). Attenuation of high-frequency body waves in the crust of the Central External Dinarides. *Journal of Seismology*, 19(4), 849–860. <https://doi.org/10.1007/s10950-015-9498-8>
- Eurocode 8. (2004). Design of structures for earthquake resistance – Part 1, General rules, seismic actions and rules for buildings. In *EN 1998-1:2004 + AC: 2009*. European Committee for Standardization CEN.
- Eurocode 8. (2011). Design of structures for earthquake resistance – Part 1, General rules, seismic actions and rules for buildings. In *HRN EN 1998-1:2011*. European Committee for Standardization CEN.
- Fajfar, P. (2000). A nonlinear analysis method for performance-based seismic design. *Earthquake Spectra*, 16(3), 573–592
- Fajfar, P., Marušić, D., & Peruš, I. (2005). Torsional effects in the pushover-based seismic analysis of buildings. *Journal of Earthquake Engineering*, 9(6), 831–854. <https://doi.org/10.1080/13632460509350568>
- Gelfi, P. (2007). *SIMQKE_GR, Programma per la generazione di accelerogrammi artificiali spettro-compatibili*. University of Brescia.
- Herak, M., & Prevolnik, S. 2017. UHS or type 1 – that is the question. *Proc. of the conference: Days of the Croatian Chamber of Civil Engineers, Lectures Summaries, part XIII, Design and Construction of Earthquake Resistant Structures*. Opatija, Croatia.
- Kreslin, M., & Fajfar, P. (2011). The extended N2 method considering higher mode effects in elevation. *Earthquake Engineering & Structural Dynamics*, 40 (14), 1571–1589. <https://doi.org/10.1002/eqe.1104>
- Labbé, P., & Paolucci, R. 2022. Developments relating to seismic action in the Eurocode 8 of Next Generation. *Proc. of the Third European Conference on Earthquake Engineering and Seismology – 3ECEES*. 26–46, Bucharest, Romania.
- Majstorović, J., Belinić, T., Namjesnik, D., Dasović, I., Herak, D., & Herak, M. (2017). Intrinsic and scattering attenuation of high-frequency S-waves in the central part of the external dinarides. *Physics of the Earth and Planetary Interiors*, 270, 73–83. <https://doi.org/10.1016/j.pepi.2017.06.005>
- Naumoski, N. 1988. Representative ensembles of strong earthquake records. CAEE - The Canadian association for earthquake engineering. (available online at <http://www.caee.uottawa.ca>)
- Naumoski, N., Tso, W. K., & Heidebrecht, A. C. 1988. A selection of representative strong motion earthquake records having different A/V ratios. Earthquake engineering research group, EERG Report 88-01, McMaster University,
- prEN_1998-1-1: 2021, Eurocode 8. 2022. Design of structures for earthquake resistance, Part 1-1: General rules and seismic action. CEN/TC 250/SC 8 N 1141, Document date 2022-01-11,
- SeismoSignal - Seismosoft. <http://www.seismosoft.com/index.htm>